

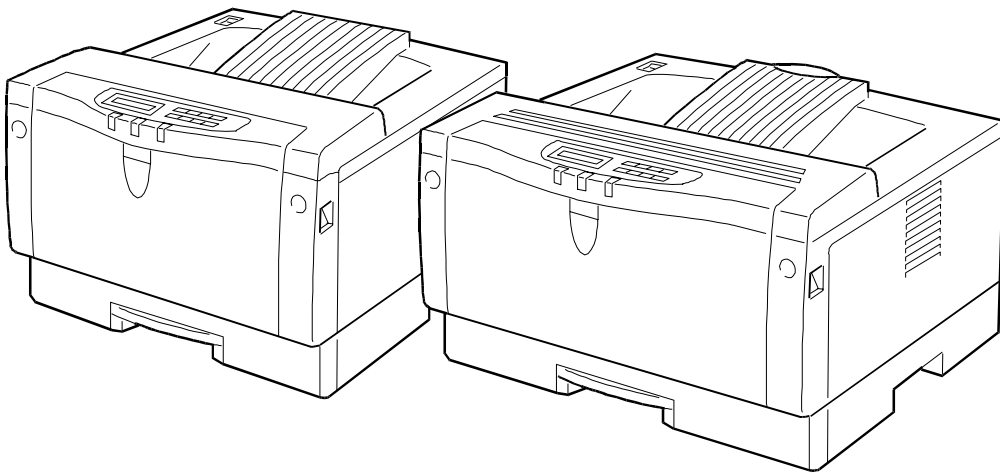

# **STINGER - P3/P4**

## **SERVICE MANUAL**



Subject to change  
Ricoh Technical Service  
March 12th 1999

## **IMPORTANT SAFETY NOTICES**

### **PREVENTION OF PHYSICAL INJURY**

1. Before disassembling or assembling parts of the printer and peripherals, make sure that the printer power cord is unplugged.
2. The wall outlet should be near the printer and easily accessible.
3. If any adjustment or operation check has to be made with exterior covers off or open while the main switch is turned on, keep hands away from electrified or mechanically driven components.
4. If a print job has started (the Data In LED has started blinking) before the printer completes the warm-up or initializing period, keep hands away from the mechanical and electrical components because the printer starts making prints as soon as the warm-up period is completed.
5. The inside and the metal parts of the fusing unit become extremely hot while the printer is operating. Avoid touching those components with your bare hands.

### **HEALTH SAFETY CONDITIONS**

Toner is non-toxic, but if you get it in your eyes by accident, it may cause temporary eye discomfort. Try to remove with eye drops or flush with water as first aid. If unsuccessful, get medical attention.

### **SAFETY AND ECOLOGICAL NOTES FOR DISPOSAL**

1. Do not incinerate the toner cassettes. Toner dust may ignite suddenly when exposed to an open flame.
2. Dispose of toner cassettes in accordance with local regulations. (This is a non-toxic unit.)
3. Dispose of replaced parts in accordance with local regulations.

## LASER SAFETY

The Center for Devices and Radiological Health (CDRH) prohibits the repair of laser-based optical units in the field. The optical housing unit can only be repaired in a factory or at a location with the requisite equipment. The laser subsystem is replaceable in the field by a qualified Customer Engineer. The laser chassis is not repairable in the field. Customer engineers are therefore directed to return all chassis and laser subsystems to the factory or service depot when replacement of the optical subsystem is required.

### **WARNING**

**Use of controls, or adjustment, or performance of procedures other than those specified in this manual may result in hazardous radiation exposure.**

### **WARNING FOR LASER UNIT**

**WARNING: Turn off the main switch before attempting any of the procedures in the Laser Unit section. Laser beams can seriously damage your eyes.**

#### **CAUTION MARKING:**



# TABLE OF CONTENTS

<b>1. OVERALL MACHINE INFORMATION .....</b>	<b>1-1</b>
1.1 SPECIFICATIONS .....	1-1
1.2 MACHINE CONFIGURATION .....	1-5
1.3 PAPER PATH .....	1-6
1.4 MECHANICAL COMPONENT LAYOUT .....	1-7
1.5 ELECTRICAL COMPONENT LAYOUT .....	1-8
1.6 ELECTRICAL COMPONENT DESCRIPTIONS.....	1-10
1.7 PRINTING PROCESS .....	1-12
1.8 BOARD STRUCTURE .....	1-14
1.8.1 OVERVIEW .....	1-14
1.8.2 MAJOR COMPONENTS.....	1-15
1.9 COMPARISON .....	1-16
<b>2. DETAILED SECTION DESCRIPTIONS.....</b>	<b>2-1</b>
2.1 PRINTING.....	2-1
2.1.1 IMAGE DATA PATH .....	2-1
2.1.2 PRINTER CONTROL BOARD .....	2-2
2.1.3 IMAGE DATA PROCESSING .....	2-3
2.1.4 HOST INTERFACE.....	2-4
2.2 LASER EXPOSURE .....	2-5
2.2.1 OVERVIEW .....	2-5
2.2.2 OPTICAL PATH.....	2-6
2.2.3 AUTO POWER CONTROL (APC) .....	2-8
2.2.4 LD SAFETY SWITCH .....	2-9
2.3 TONER CARTRIDGE .....	2-10
2.3.1 OVERVIEW .....	2-10
2.3.2 DRIVE.....	2-11
2.3.3 DRUM CHARGE .....	2-12
2.3.4 DEVELOPMENT.....	2-13
2.3.5 DRUM CLEANING.....	2-15
2.4 IMAGE TRANSFER AND PAPER SEPARATION .....	2-16
2.4.1 OVERVIEW .....	2-16
2.4.2 TRANSFER ROLLER CLEANING .....	2-17
2.5 PAPER FEED .....	2-18
2.5.1 OVERVIEW .....	2-18
2.5.2 PAPER TRAY .....	2-20
2.5.3 BY-PASS TRAY.....	2-25
2.5.4 PAPER REGISTRATION.....	2-27
2.6 IMAGE FUSING.....	2-29
2.6.1 OVERVIEW .....	2-29
2.6.2 FUSING .....	2-30
2.6.3 FUSING UNIT DRIVE .....	2-30
2.6.4 PRESSURE ROLLER/PAPER EXIT.....	2-31

2.6.5	FUSING UNIT DRIVE RELEASE .....	2-31
2.6.6	NEW FUSING UNIT DETECTION (STINGER - P3 ONLY).....	2-32
2.6.7	FUSING TEMPERATURE CONTROL.....	2-33
2.6.8	OVERHEAT PROTECTION.....	2-35
2.6.9	ENERGY SAVER MODE.....	2-36
2.7	COVER OPEN DETECTION .....	2-37
2.7.1	FRONT COVER LOCK.....	2-37
2.7.2	FRONT COVER SAFETY SWITCH.....	2-37
2.7.3	REMOVING THE FUSING UNIT .....	2-38
2.8	ENGINE CONTROL BOARD.....	2-39
2.8.1	PCB LAYOUT .....	2-39
2.8.2	DEVICES .....	2-40
2.8.3	STRUCTURE.....	2-41
2.8.4	CONNECTION TO THE ECB .....	2-42
2.9	SIGNAL TABLE .....	2-44
2.10	PRINTER CONTROL BOARD.....	2-47
2.10.1	PCB LAYOUT .....	2-47
2.10.2	DEVICES .....	2-48
<b>3.</b>	<b>INSTALLATION.....</b>	<b>3-1</b>
3.1	INSTALLATION REQUIREMENTS .....	3-1
3.1.1	ENVIRONMENT .....	3-1
3.1.2	POWER REQUIREMENTS.....	3-1
3.2	PRINTER INSTALLATION.....	3-2
3.3	PAPER FEED UNIT INSTALLATION .....	3-2
3.4	ENVELOPE FEEDER INSTALLATION.....	3-2
3.5	HARD DISK INSTALLATION.....	3-2
3.6	MEMORY UNIT INSTALLATION.....	3-2
3.7	NETWORK INTERFACE BOARD INSTALLATION .....	3-2
3.8	CHECKING THE CONNECTIONS .....	3-3
3.8.1	CONNECTION BETWEEN MAIN PRINTER CONTROL BOARD (AND RELATED OPTIONS: HDD, RAM SIMM, NIC) AND OPTIONAL HDD & PERIPHERALS.....	3-3
3.8.2	CONNECTION BETWEEN PRINTER CONTROL BOARD AND NETWORK INTERFACE BOARD.....	3-6
3.8.3	PRINTING THE NETWORK INTERFACE BOARD CONFIGURATION SHEET .....	3-6
<b>4.</b>	<b>SERVICE PROCEDURES AND TABLES .....</b>	<b>4-1</b>
4.1	OVERVIEW .....	4-1
4.2	SERVICE PROGRAM MODE.....	4-2
4.2.1	ENABLING AND DISABLING SERVICE PROGRAM MODE .....	4-2
4.2.2	SERVICE PROGRAM MODE MENU TREE .....	4-3
4.2.3	SERVICE MODE MENU TABLE.....	4-5
4.2.4	PRINT LOG.....	4-9
4.2.5	PRINTER ID.....	4-13
4.3	IC CARD BOOT SERVICE MODE .....	4-15

4.3.1	OVERVIEW .....	4-15
4.3.2	ENABLING AND DISABLING IC CARD BOOT SERVICE MODE .....	4-15
4.3.3	IC CARD BOOT SERVICE MODE TREE .....	4-16
4.3.4	SERVICE MENU TABLE .....	4-17
4.4	EEPROM AND NVRAM RESET PROCEDURES.....	4-18
4.5	DOWNLOADING NEW CONTROLLER SOFTWARE .....	4-19
4.5.1	OVERVIEW .....	4-19
4.5.2	DOWNLOADING NEW FIRMWARE FROM AN IC CARD.....	4-20
4.6	USER MENU .....	4-23
4.7	ECB TEST PATTERN.....	4-24
4.8	DIAGNOSTIC TEST MODES .....	4-25
4.8.1	OVERVIEW .....	4-25
4.8.2	POWER-UP DIAGNOSTIC MODE .....	4-25
4.8.3	DETAILED DIAGNOSTIC MODE .....	4-26
4.8.4	DIAGNOSTIC TEST DETAILS.....	4-27
<b>5.</b>	<b>PREVENTIVE MAINTENANCE .....</b>	<b>5-1</b>
5.1	PREVENTIVE MAINTENANCE SCHEDULE.....	5-1
<b>6.</b>	<b>REPLACEMENT AND ADJUSTMENT .....</b>	<b>6-1</b>
6.1	COVERS.....	6-1
6.1.1	EXTERIOR COVER REMOVAL .....	6-1
6.1.2	FRONT COVER REMOVAL .....	6-2
6.1.3	CONTROL BOARD COVER REMOVAL .....	6-3
6.2	FUSING UNIT .....	6-4
6.2.1	FUSING UNIT REPLACEMENT .....	6-4
6.2.2	HOT ROLLER AND FUSING LAMP REPLACEMENT .....	6-5
6.2.3	PRESSURE ROLLER REPLACEMENT .....	6-7
6.2.4	FUSING THERMOFUSE REPLACEMENT .....	6-8
6.2.5	FUSING DRAWER CONNECTOR REPLACEMENT.....	6-9
6.3	TRANSFER ROLLER .....	6-10
6.3.1	TRANSFER ROLLER REPLACEMENT .....	6-10
6.4	PAPER FEED .....	6-11
6.4.1	BY-PASS TRAY REMOVAL .....	6-11
6.4.2	BY-PASS FEED ROLLER REPLACEMENT.....	6-12
6.4.3	PAPER FEED ROLLER REPLACEMENT .....	6-15
6.4.4	RELAY ROLLER REPLACEMENT (STINGER - P4 ONLY).....	6-17
6.4.5	FRICTION PAD REPLACEMENT .....	6-18
6.4.6	TRAY PAPER FEED CLUTCH REPLACEMENT .....	6-19
6.5	LASER UNIT.....	6-20
6.5.1	CAUTION DECAL LOCATIONS .....	6-20
6.5.2	LASER UNIT/SHIELD GLASS REPLACEMENT .....	6-21
6.5.3	LD UNIT/LASER SYNCHRONIZATION DETECTOR REPLACEMENT .....	6-22
6.5.4	POLYGONAL MIRROR MOTOR REPLACEMENT .....	6-23
6.5.5	LD UNIT/POLYGONAL MIRROR MOTOR REPLACEMENT .....	6-24

6.6 OTHERS.....	6-25
6.6.1 TONER NEAR-END SENSOR REPLACEMENT .....	6-25
6.6.2 MAIN MOTOR/GEAR BOX REMOVAL .....	6-26
6.6.3 ENGINE CONTROL BOARD REPLACEMENT .....	6-27
6.6.4 PRINTER CONTROL BOARD REPLACEMENT .....	6-28
6.6.5 HIGH VOLTAGE SUPPLY BOARD .....	6-29
6.6.6 POWER SUPPLY UNIT REPLACEMENT .....	6-30
6.7 PRINT REGISTRATION ADJUSTMENT .....	6-31
<b>7. TROUBLESHOOTING.....</b>	<b>7-1</b>
7.1 OPERATOR ERRORS .....	7-1
7.2 PRINTER ENGINE SC CODES.....	7-6
7.3 DIAGNOSTIC ERROR CODES.....	7-9
7.3.1 DIAGNOSTIC ERROR CODE TABLE .....	7-9
7.4 ELECTRICAL COMPONENT DEFECTS.....	7-17
7.4.1 SENSORS .....	7-17
7.4.2 SWITCHES.....	7-17
7.4.3 FUSES.....	7-17

## OPTION

### ENVELOPE FEEDER (Machine Code: G913)

<b>1. OVERALL INFORMATION.....</b>	<b>G913-1</b>
1.1 SPECIFICATIONS.....	G913-1
1.2 MECHANICAL COMPONENT LAYOUT.....	G913-1
<b>2. DETAILED SECTION DESCRIPTIONS.....</b>	<b>G913-2</b>
2.1 PAPER LIFT .....	G913-2
<b>3. INSTALLATION.....</b>	<b>G913-3</b>
<b>4. REPLACEMENT AND ADJUSTMENT.....</b>	<b>G913-4</b>
4.1 FRICTION PAD REPLACEMENT.....	G913-4

### PAPER FEED UNIT (Machine Code: G914)

<b>1. OVERALL MACHINE INFORMATION .....</b>	<b>G914-1</b>
1.1 SPECIFICATIONS.....	G914-1
1.1.1 STINGER - P3 .....	G914-1
1.1.2 STINGER - P4 .....	G914-1
1.2 MECHANICAL COMPONENT LAYOUT.....	G914-2
1.3 ELECTRICAL COMPONENT LAYOUT .....	G914-3
1.4 ELECTRICAL COMPONENT DESCRIPTION.....	G914-4
<b>2. DETAILED SECTION DESCRIPTIONS.....</b>	<b>G914-5</b>
2.1 PAPER SIZE DETECTION.....	G914-5
2.2 PAPER LIFT .....	G914-5
2.3 PAPER END DETECTION .....	G914-5
2.4 PAPER NEAR END DETECTION .....	G914-5
2.5 PAPER FEED .....	G914-6
<b>3. INSTALLATION.....</b>	<b>G914-8</b>
<b>4. REPLACEMENT AND ADJUSTMENT.....</b>	<b>G914-9</b>
4.1 PAPER FEED UNIT (OPTION FOR STINGER - P3).....	G914-9
4.1.1 PAPER FEED ASSEMBLY REMOVAL .....	G914-9
4.1.2 DRIVE ROLLER REPLACEMENT.....	G914-10
4.1.3 PAPER FEED MOTOR REPLACEMENT .....	G914-11



4.1.4	PAPER FEED CLUTCH REMOVAL .....	G914-12
4.1.5	PAPER FEED UNIT BOARD/PAPER SIZE SWITCH REPLACEMENT .....	G914-13
4.2	PAPER FEED UNIT (OPTION FOR STINGER - P4).....	G914-14
4.2.1	PAPER FEED ROLLER/PAPER FEED CLUTCH REPLACEMENT .....	G914-14
4.2.2	PAPER DRIVE ROLLER REPLACEMENT.....	G914-15
4.2.3	DRIVE ROLLER IDLER/FRICTION PAD REPLACEMENT .....	G914-16
4.2.4	PAPER FEED MOTOR/PAPER FEED UNIT BOARD REPLACEMENT .....	G914-17

## **NETWORK INTERFACE BOARD (Machine Code: G919)**

<b>1.</b>	<b>OVERALL MACHINE INFORMATION .....</b>	<b>G917-1</b>
1.1	SPECIFICATIONS.....	G917-1
<b>2.</b>	<b>INSTALLATION PROCEDURE .....</b>	<b>G917-2</b>
2.1	HARDWARE INSTALLATION .....	G917-2
2.1.1	SERIAL NUMBER AND MAC ADDRESS.....	G917-2
2.1.2	STATUS SHEET.....	G917-2
2.2	PROGRAMMING NETWORK/PROTOCOL PARAMETERS.....	G917-3
2.2.1	IPX NETWORK.....	G917-3
2.2.2	TCP/IP NETWORK.....	G917-4
2.2.3	ETHERTALK (APPLETALK) NETWORK.....	G917-5
2.3	SETUP FOR VARIOUS NETWORK TYPES .....	G917-6
2.3.1	PEER-TO-PEER NETWORK.....	G917-6
2.3.2	NOVELL NETWARE NETWORK.....	G917-7
2.3.3	TCP/IP NETWORK.....	G917-7
<b>3.</b>	<b>SERVICE TABLES AND PROCEDURES .....</b>	<b>G917-8</b>
3.1	FACTORY RESET (NVRAM CLEAR).....	G917-8
3.2	FLASH ROM UPDATE .....	G917-9
3.2.1	INTRODUCTION .....	G917-9
3.2.2	FLASHUP UTILITY (FOR NOVELL IPX NETWORKS).....	G917-10
3.2.3	FTPD utility (FOR TCP/IP NETWORKS) .....	G917-13
<b>4.</b>	<b>TROUBLESHOOTING.....</b>	<b>G917-16</b>
4.1	LED INDICATIONS.....	G917-16

# APPENDIX

<b>1. DOWNLOADING CONTROLLER FIRMWARE .....</b>	<b>APPENDIX-1</b>
1.1 OVERVIEW .....	APPENDIX-1
1.1.1 IC CARD (FLASH CARD) .....	APPENDIX-1
1.1.2 PC, VIA PARALLEL PORT .....	APPENDIX-2
1.1.3 DIMM .....	APPENDIX-2
1.1.4 RELEASING NEW CONTROLLER FIRMWARE .....	APPENDIX-3
1.2 SERVICE TOOLS.....	APPENDIX-4
1.2.1 OPERATION PANEL.....	APPENDIX-4
1.2.2 SERVICE TOOL MENUS .....	APPENDIX-5
1.2.3 STINGER SERVICE UTILITY (SSU) .....	APPENDIX-7
1.3 USING AN IC CARD.....	APPENDIX-8
1.3.1 PREPARING THE IC CARD.....	APPENDIX-8
1.3.2 DOWNLOADING FROM THE IC CARD TO THE PRINTER.....	APPENDIX-13
1.4 USING A DIMM .....	APPENDIX-14
1.4.1 PREPARING THE DIMM.....	APPENDIX-14
1.4.2 DOWNLOADING FROM THE DIMM TO THE PRINTER.....	APPENDIX-19
1.5 COPYING FROM A PC DIRECTLY.....	APPENDIX-20
1.5.1 PREPARATION.....	APPENDIX-20
1.5.2 DOWNLOADING TO THE FLASH MEMORY.....	APPENDIX-22
1.6 SSU TROUBLESHOOTING .....	APPENDIX-26

# 1. OVERALL MACHINE INFORMATION

## 1.1 SPECIFICATIONS

Configuration:	Desktop
Print Process:	Laser beam scanning & electrophotographic printing Monocomponent toner development
Printing Speed (600 dpi):	Stinger - P3: Maximum 20 pages per minute (A4/LT LEF) Stinger - P4: Maximum 14 pages per minute (A4/LT SEF)
First Print Speed:	Stinger - P3: 5.5 s or less (A4/LT - LEF, standard tray) Stinger - P4: 6.5 s or less (A4/LT - SEF, standard tray)
Resolution:	True 1,200 x 1,200 dpi (available for PCL6 or PostScript) 600 x 600 dpi 300 x 300 dpi (simulated by doubling pixel width and height at 600 dpi resolution)
Printer Language	PCL6/PCL5e Compatible with Laser Jet 5N driver and printer. Windows 3.1x/95/98, Windows NT4.0 drivers available. PostScript Level II Windows 95/98, Windows NT4.0, and Macintosh (OS 7.5 or later) PPDs are available.
Printer Fonts:	PCL6 35 Intellifonts 10 True Type fonts 1 Bitmap font PS2 35 Adobe type 1 fonts
Printer Interface:	Bi-directional IEEE1284 parallel x 1 (Standard) Ethernet (100 Base-TX/10 Base-T for TCP/IP, IPX/SPX, EtherTalk) RS232C interface (Optional)

Printing Paper Size: Stinger - P3:  
 Maximum A3/11" x 17"  
 Minimum A5 LEF - Standard Tray  
 B6 SEF - By-pass Tray  
 A5 LEF - Optional PFU  
 Custom paper size (PCL 6/PS): By-pass Tray  
 11.69" x 17" ~ 3.88" x 5.83"  
 (297 x 431.8 ~ 98.4 x 148 mm)  
 Envelope: By-pass & Envelope Feeder  
 Com#10, C6, DL, Monarch

Stinger - P4:  
 Maximum A4/LG (only A4/LT for Standard Tray)  
 Minimum A4/LT – Standard Tray  
 B6 SEF - By-pass Tray  
 A5 LEF - Optional PFU  
 Custom paper size (PCL 6/PS): By-pass Tray  
 8.5" x 14" ~ 3.88" x 5.83"  
 (216 x 355.6 ~ 98.4 x 148 mm)  
 Envelope: By-pass & Envelope Feeder  
 Com#10, C6, DL, Monarch



Printing Paper Weight: Paper tray: 60 ~ 106 g/m<sup>2</sup>, 16 ~ 28 lb  
 By-pass: 60 ~ 162 g/m<sup>2</sup>, 16 ~ 43 lb

Power Source: Stinger - P3:  
 120 V, 60 Hz: More than 8.0 A (for North America)  
 220 V ~ 240 V, 50/60 Hz: More than 8.0 A (for Europe)

Stinger - P4:  
 120 V, 60 Hz: More than 6.0 A (for North America)  
 220 V ~ 240 V, 50/60 Hz: More than 5.0 A (for Europe)

Power Consumption:

	<b>Stinger - P3</b>	<b>Stinger - P4</b>
Maximum	795 W or less	600 W or less
Printing	480 W or less	380 W or less
Energy Saver	30 W or less	30 W or less

Noise Emission (All Options Installed):

	<b>Stinger - P3</b>	<b>Stinger - P4</b>
<b>Sound Power Level</b>		
Printing	64 dB or less	59 dB or less
Stand-by	48 dB or less	48 dB or less

**NOTE:** The above measurements were made in accordance with ISO 9296 at the operator position.



Utility Software  
(Main frame CD-ROM):

- Printer Drivers
- PS PPD files
- Font Manager
- Aficio Manager
- Operating Instructions (G031/G032 -22, -27, -29)

Utility Software  
(Optional Network Interface  
Board):

- IP-P2P
- IPXP2P
- MAP
- Bootpl
- NW setup
- NIB User's Manual
- Acrobat Reader

Maintenance Kit:

- Fusing Unit x 1
- Transfer Unit x 1
- Friction Pad x 1
- Paper Feed Roller x 3 (Stinger - P3)
- Paper Feed Roller x 1 (Stinger - P4)

## 1.2 MACHINE CONFIGURATION

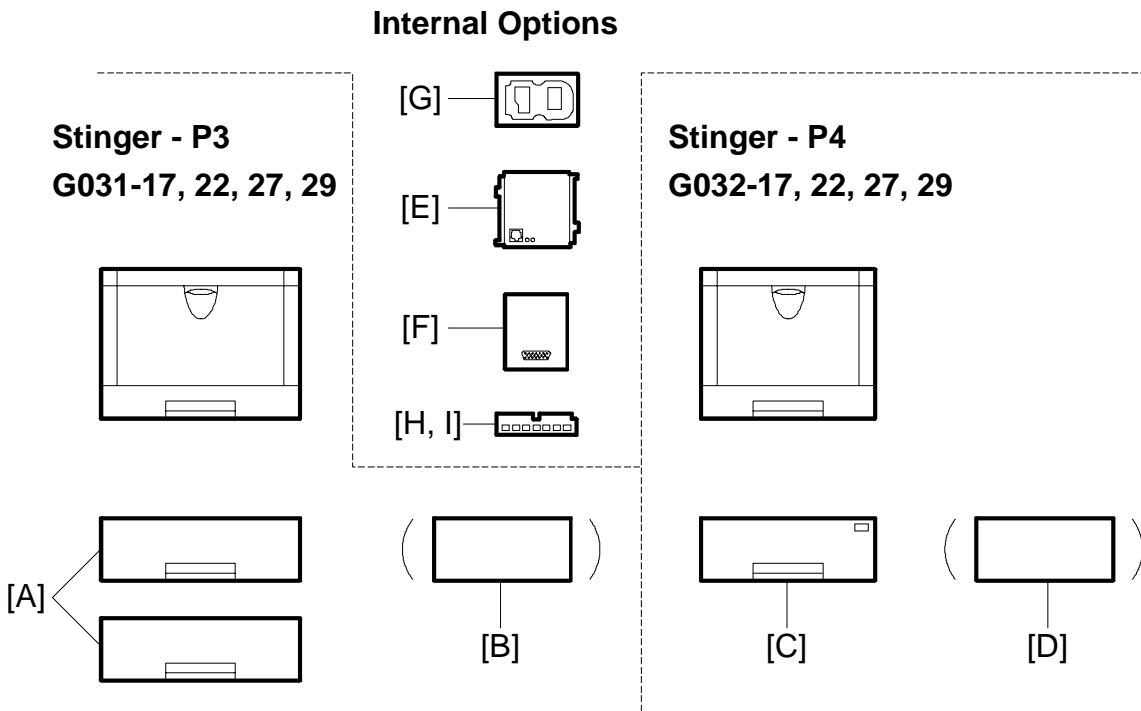

G031V500.WMF

No.	Item	Machine Code
<b>Stinger - P3</b>		
A	Paper Feed Unit Type 2000 (A4/LT) Paper Feed Unit Type 2000 (A3/DLT)	G915-17, -27 G914-17, -27
B	*Envelope Feeder Type 2000	G913-17
<b>Stinger - P4</b>		
C	Paper Feed Unit Type 1400	G914-57
D	Envelope Feeder Type 1400	G913-57
<b>Internal Options</b>		
E	Network Interface Board Type 2000	G919-17
F	RS232C Board Type 2000	G527-17
G	Hard Disk Drive Type 2000	G690-17
H	Memory Unit Type 204 (16 MB)	G688-04
I	Memory Unit Type 204 (32 MB)	G688-05

**\*NOTE:** The envelope feeder for the Stinger - P3 can only be installed in place of the optional 2nd paper tray.

### 1.3 PAPER PATH

#### *Stinger - P3*

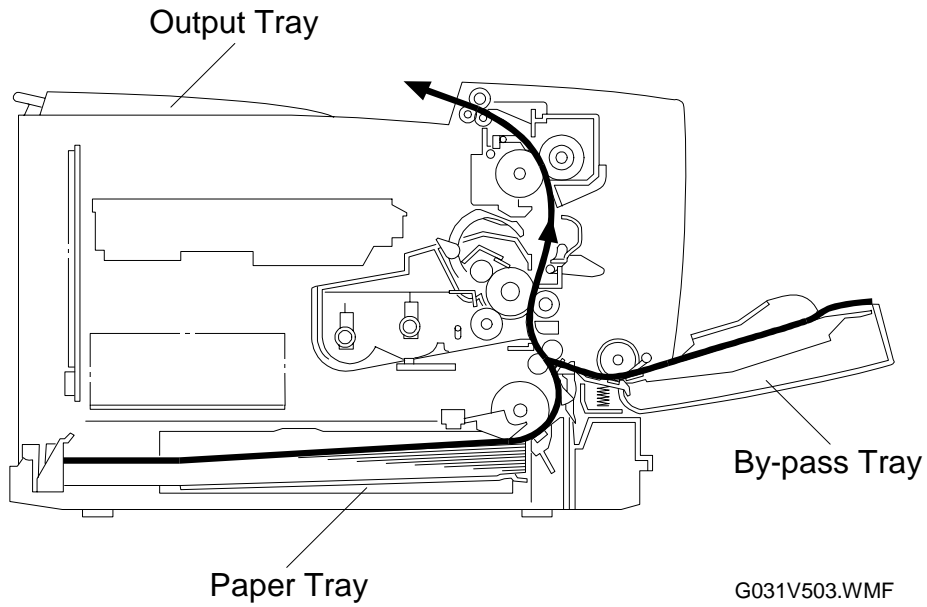

#### *Stinger - P4*

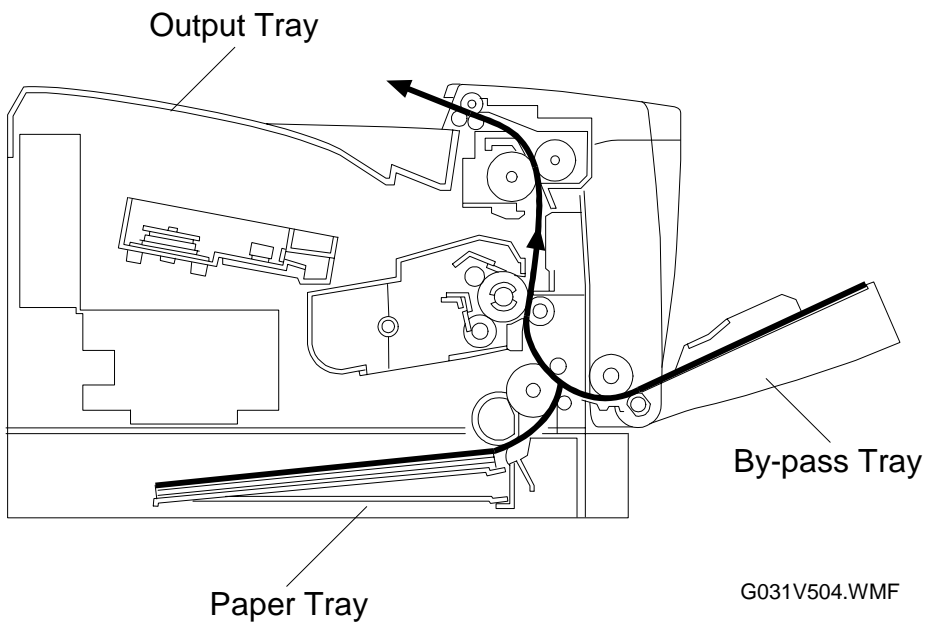



Overall Information

# 1.4 MECHANICAL COMPONENT LAYOUT

## Stinger - P3

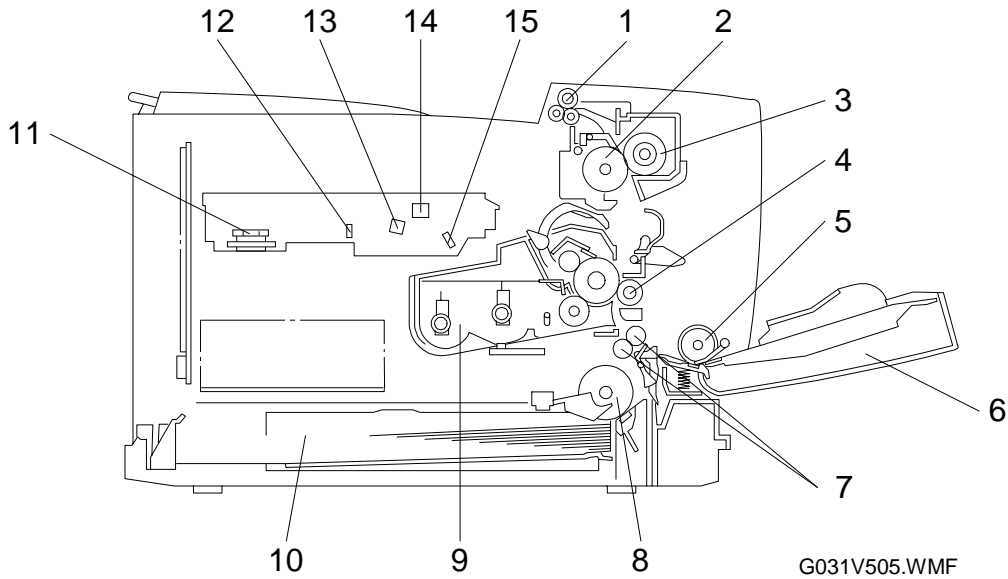

G031V505.WMF

## Stinger - P4

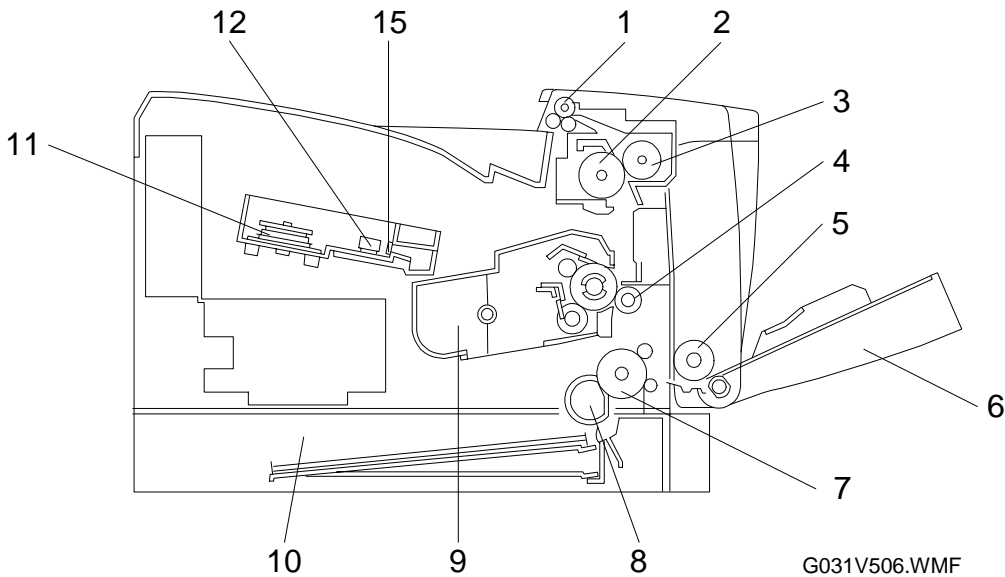

G031V506.WMF

- |  |   |
|--|---|
| 1. Exit Roller                         | 9. Toner Cartridge                      |
| 2. Hot Roller                          | 10. Paper Tray                          |
| 3. Pressure Roller                     | 11. Polygonal Mirror Motor              |
| 4. Transfer Roller                     | 12. 1st Mirror (Stinger - P3)           |
| 5. By-pass Feed Roller                 | F-theta Lens (Stinger - P4)             |
| 6. By-pass Tray                        | 13. Barrel Toroidal Lens (Stinger - P3) |
| 7. Registration Rollers (Stinger - P3) | 14. F-theta Mirror (Stinger - P3)       |
| Relay Roller (Stinger - P4)            | 15. Shield Glass                        |
| 8. Paper Feed Roller                   |   |

## 1.5 ELECTRICAL COMPONENT LAYOUT

### *Stinger - P3*

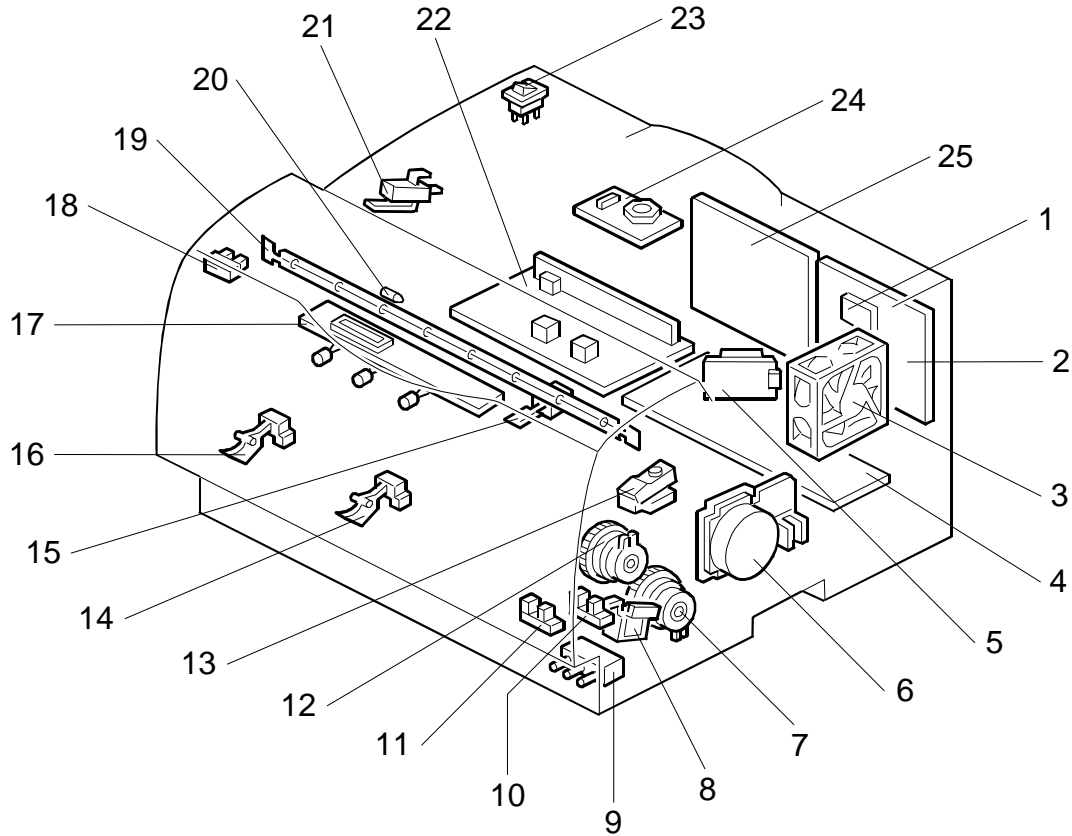

G031V501.WMF

- |                                   |                                |
|-----------------------------------|--------------------------------|
| 1. Laser Synchronization Detector | 14. Tray Paper End Sensor      |
| 2. Engine Control Board           | 15. Fusing Thermistor          |
| 3. Exhaust Fan Motor              | 16. Tray Paper Near-end Sensor |
| 4. High Voltage Supply Board      | 17. Control Panel Board        |
| 5. LD Drive Board                 | 18. Fusing Exit Sensor         |
| 6. Main Motor                     | 19. Fusing Lamp                |
| 7. Tray Paper Feed Clutch         | 20. Thermofuse                 |
| 8. By-pass Feed Solenoid          | 21. Front Cover Safety Switch  |
| 9. Tray Paper Size Switch         | 22. Power Supply Unit          |
| 10. Registration Sensor           | 23. Main Switch                |
| 11. By-pass Tray Paper Sensor     | 24. Polygonal Mirror Motor     |
| 12. Registration Clutch           | 25. Printer Control Board      |
| 13. Toner Near-end Sensor         |                                |

**Stinger - P4**

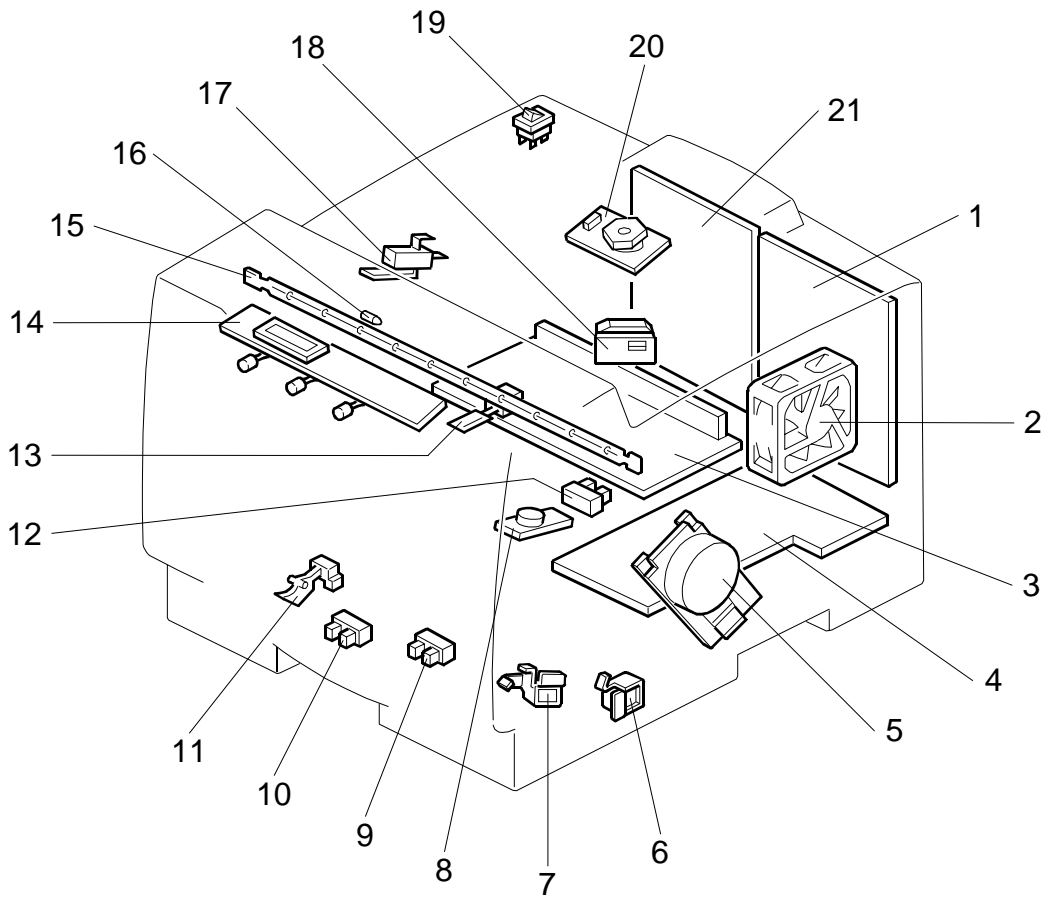

G031V502.WMF

- |                               |   |
|-------------------------------|---|
| 1. Engine Control Board       | 12. Fusing Exit Sensor                                |
| 2. Exhaust Fan Motor          | 13. Fusing Thermistor                                 |
| 3. Power Supply Unit          | 14. Control Panel Board                               |
| 4. High Voltage Supply Board  | 15. Fusing Lamp                                       |
| 5. Main Motor                 | 16. Thermofuse  |
| 6. Tray Paper Feed Solenoid   | 17. Front Cover Safety Switch                         |
| 7. By-pass Feed Solenoid      | 18. LD Drive Board<br>(with synchronization detector) |
| 8. Toner Near-end Sensor      | 19. Main Switch                                       |
| 9. Registration Sensor        | 20. Polygonal Mirror Motor                            |
| 10. By-pass Tray Paper Sensor | 21. Printer Control Board                             |
| 11. Tray Paper End Sensor     |   |

## 1.6 ELECTRICAL COMPONENT DESCRIPTIONS

Refer to the electrical component layout and the point-to-point diagram on the waterproof paper in the pocket for the locations of these components.

Symbol	Description	Note	Index No.	
			P3	P4
<b>Printed Circuit Boards</b>				
PCB1	High Voltage Supply Board	Supplies high voltage to the drum charge roller, development roller, and transfer roller.	4	4
PCB2	Power Supply Unit (PSU)	Provides dc power to the system and ac power to the fusing lamp.	22	3
PCB3	LD Drive Board	Controls the laser diode.	5	18
PCB4	Control Panel	Controls the display panel, LED, and the touch key pad.	17	14
PCB5	Engine Control Board (ECB)	Controls all base engine functions either directly or through other control boards.	2	1
PCB6	Printer Control Board	Controls the PC interface, print image processing, operation panel, and other controller options.	25	21
<b>Motors</b>				
M1	Main	Drives the main body components.	6	5
M2	Polygonal Mirror	Turns the polygonal mirror.	24	20
M3	Exhaust Fan	Removes heat from the printer.	3	2
<b>Sensors</b>				
S1	Fusing Exit	Detects misfeeds.	18	12
S2	Tray Paper End	Informs the CPU when the paper tray runs out of paper.	14	11
S3	Tray Paper Near-end (Stinger - P3)	Informs the CPU when the amount of paper in the tray becomes low (50±30 sheets).	16	—
S4	By-pass Tray Paper	Informs the CPU when there is paper on the by-pass tray.	11	10
S5	Registration	Detects the leading edge of the paper to determine when to stop the paper feed clutch, and detects misfeeds.	10	9
S6	Toner Near-end	Detects when toner is low.	13	8
<b>Switches</b>				
SW1	Main	Supplies power to the machine.	23	19
SW2	Front Cover Safety	Cuts the +5VLD and +24 V dc power lines and detects whether the front cover is open or not.	21	17
SW3	Tray Paper Size (Stinger - P3)	Determines the size of paper in the paper tray, based on the dial setting.	9	—

Symbol	Description	Note	Index No.	
			P3	P4
<b>Magnetic Clutches</b>				
MC1	Tray Paper Feed (Stinger - P3)	Starts paper feed from the paper tray.	7	—
MC2	Registration (Stinger - P3)	Drives the registration rollers.	12	—
<b>Solenoids</b>				
SOL1	By-pass Feed	Starts paper feed from the by-pass tray.	8	7
SOL2	Tray Paper Feed (Stinger - P4)	Starts paper feed from the paper tray.	—	6
<b>Lamps</b>				
L1	Fusing	Heats the hot roller.	19	15
<b>Thermistors</b>				
TH1	Fusing	Monitors the temperature of the hot roller.	15	13
<b>Thermofuses</b>				
TF1	Fusing	Provides back-up overheat protection in the fusing unit.	20	16
<b>Others</b>				
LSD1	Laser Synchronization Detector (Stinger - P3)	Detects the laser beam at the start of the main scan.	1	—

## 1.7 PRINTING PROCESS

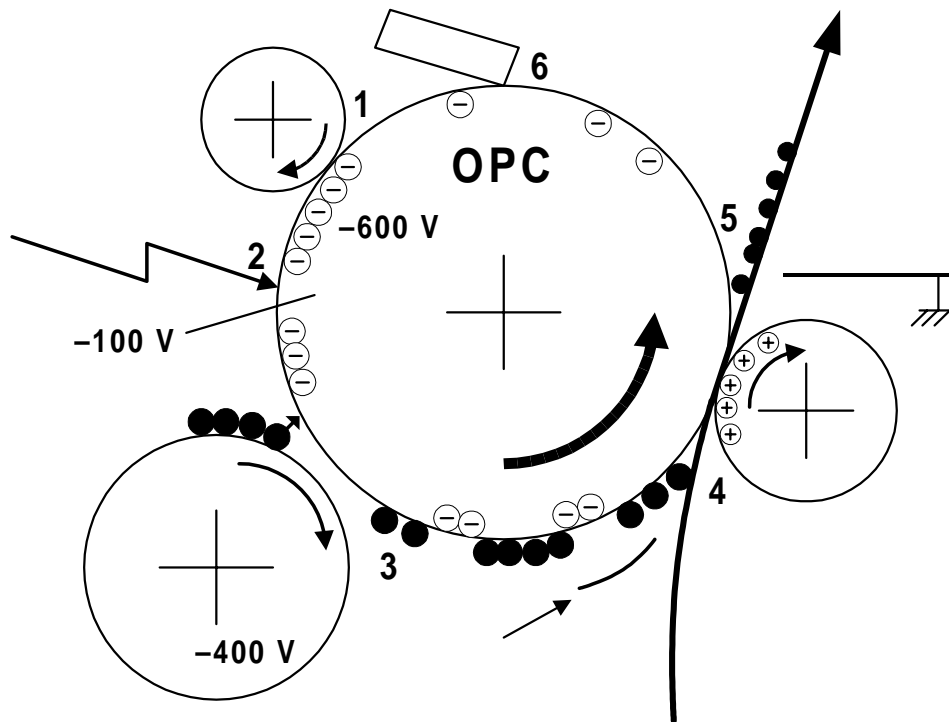

G031V507.WMF

Stinger - P3/4 use an all-in-one type of toner cartridge that includes the drum, toner, development roller, charge roller and other components.

### 1. DRUM CHARGE

In the dark, the charge roller gives a negative charge of -600 volts to the organic photo-conductive (OPC) drum. The charge remains on the surface of the drum because the OPC layer has a high electrical resistance in the dark.

### 2. LASER EXPOSURE

The processed print image data from the engine control board (ECB) is transferred to the drum by a laser beam, which forms an electrical latent image on the drum surface. The areas exposed by the laser beam drop to about -100 volts.

### 3. DEVELOPMENT

The magnetic development brush on the development roller approaches the latent image on the drum. The development roller gives a negative bias of -400 volts to the toner. Toner particles jump and electrostatically attach to the areas of the drum surface where the laser reduced the negative charge on the drum.

**4. IMAGE TRANSFER**

Paper is fed to the area between the drum surface and the transfer roller at the proper time for aligning the print paper and the developed image on the drum surface. Then, the transfer roller applies a positive current to the reverse side of the paper (the size of the current depends on the resolution and the paper size). This pulls the toner particles from the drum surface to the paper. At the same time, the paper is attracted to the transfer roller.

**5. PAPER SEPARATION**

Paper separates from the drum as a result of the electrostatic attraction between the paper and the transfer roller. The discharge plate helps separate the paper from the drum.

**6. CLEANING**

The cleaning blade removes any toner remaining on the drum surface after the image is transferred to the paper.

**7. QUENCHING**

There is no quenching mechanism.

# 1.8 BOARD STRUCTURE

## 1.8.1 OVERVIEW

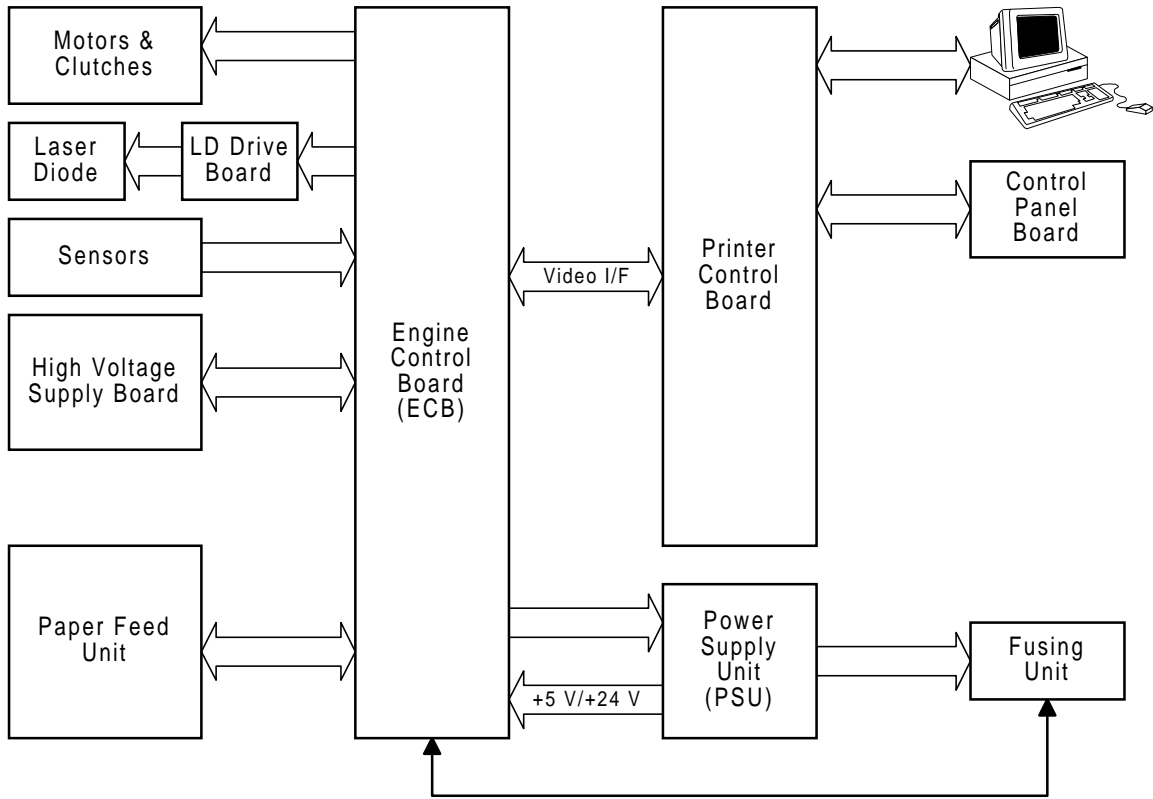

G031V508.WMF

The engine control firmware controls the components connected to the engine control board (ECB). The printer control board controls the control panel board. The printer control board is also connected to the personal computer.



## 1.8.2 MAJOR COMPONENTS

### 1. Engine Control Board (ECB)

This is the printer engine control board. It controls the following functions:

- Engine sequence
- Machine control, printer engine control
- Timing control for peripherals
- Video control
- Drive control for the sensors, motors, solenoids, and high voltage supply board
- PWM control for edge smoothing (PWM is done on the printer control board)

### 2. Printer Control Board

This is the machine's main control board. It controls the following functions:

- IEEE 1284 parallel port
- Edge smoothing and toner saving
- Engine control board
- Control panel board
- Interfacing with the HDD and NIB

### 3. LD Drive Board

This is the laser diode drive circuit board.

### 4. Power Supply Unit (PSU)

Provides dc power to the system and ac power to the fusing lamp.

### 5. High Voltage Supply Board

Supplies high voltage to the drum charge roller, development roller, and transfer roller.

### 6. Fusing Unit

Fuses toner to the paper. The fusing lamp is controlled by the ECB.

### 7. Control Panel Board

Controls the display panel, the LED, and the touch keypad.

## 1.9 COMPARISON

	Stinger - P3	Stinger - P4	V20
Standard Paper Tray	250 sheets	250 sheets	250 sheets
Standard Bypass Tray	100 sheets	100 sheets	100 sheets
Optional Paper Tray	500 sheets x 2	500 sheets	500 sheets x 2 + 1,500 sheets
Envelope Feeder	10 envelopes	5 envelopes	100 envelopes
Output Paper Capacity	250 sheets		Standard Output Tray: 400 sheets External Tray: 100 sheets
Input Paper Size (Std./Opt. Tray)	A3/11" x 17" ~ A5 (LEF)	A4 ~ A5 (LEF)	A3/11" x 17" ~ A5/5.5" x 8.5" (LEF)
Input Paper Size (By-pass Tray)	A3/11" x 17" ~ B6 (SEF) free: 11.69" x 17" ~ 3.88" x 5.83"	A4/LG ~ B6 (SEF) free: 8.5" x 14" ~ 3.88" x 5.83"	A3/11"x17" ~ A5/5.5" x 8.5" (SEF)
First Print Speed	5.5 s or less (A4/LT ~ LEF, Standard Tray)	6.5 s or less (A4/LT ~ SEF, Standard Tray)	
Duplex Printing	N/A		Option
Memory (Std./Max. with Opt.)	8 MB/40 MB	8 MB/40 MB	8 MB/68 MB
HDD (Option)	1.6 GB		
Fonts	PCL6 (35 Intellifonts, 10 True Type fonts and 1 bitmap font) PS2 (35 Adobe type 1 fonts)		PCL5e (35 Intellifont, 10 True Type font and 1 bitmap font) PS2 (35 Adobe type 1 fonts)
Interface	Bi-directional parallel x 1 Ethernet (100 Base-Tx/10 Base-T for TCP/IP, IPX/SPX, Ether Talk) RS232C (Optional)		Bi-directional parallel (Standard) Ethernet (10 Base 2/T for IPX/SPX, TCP/IP, Apple Talk) Token Ring (4 Mbps, 16 Mbps for IPS/SPX, TCP/IP, Apple Talk)
Warm-up Time	Less than 39 seconds: 23°C (73°F)		Less than 60 seconds: 23°C (73°F)
Utilities	Aficio Manager		
Dimensions (mm: W x D x H)	450 x 420 x 270 mm (with Std. Tray adjusted for A4) 450 x 555 x 270 mm (with Std. Tray adjusted for A3)	360 x 420 x 270 mm (with Std. Tray adjusted for A4)	530 x 625 x 472 mm (with by-pass tray closed, without the optional paper tray unit, without options)
Weight	Less than 15 kg (33 lb.)	Less than 12 kg (27 lb.)	Less than 44.5 kg (99 lb.)
Consumable Yield	Toner Cartridge: 14 K	Toner Cartridge: 8 K	
PM Kit	Maintenance Kit: 80 K	Maintenance Kit: 60 K	
Technology	Laser beam scanning & electrophotographic printing Monocomponent development		Laser beam scanning & electrophotographic printing Dualcomponent development
Resolution	True 1,200 x 1,200 dpi (PCL6/PS) 600 x 600 dpi (PCL6/PCL5e/PS) 300 x 300 dpi (PCL5e/PS)		600 dpi, 400 dpi (available when the PostScript option is installed), 300 dpi (simulated by doubling pixel width and height at 600 dpi resolution)
Continuous Print Speed	20 ppm (A4 SEF)	14 ppm (A4 LEF)	25 ppm (A4/LT LEF)
Power Consumption	Max. 795 W	Max. 600 W	Max. 950 W
Drivers	PCL6/5e version : Windows 3.1x, 95(98), Windows NT 4.0 PS PPD: Windows 95 (98), Windows NT 4.0, Macintosh OS 7.5 or later		PCL version : Windows 3.1xx, 95, Windows NT 3.51/4.0 (PCL & PS version: Macintosh)
Halftoning	○	○	○
Electrical Sorting	○	○	○
Diagnostic Test Mode	○	○	○
Test Print	○	○	○
Hex Dump List	○	○	○ (N/A from Driver)
Smoothing	○	○	○
Rotated Sorting	N/A	N/A	N/A
Toner Saving Mode	○	○	○
PDL Auto Change	○	○	○
Overlays (PCL)	○	○	N/A
Auto Cassette Change	○	○	○
Energy Saver	○	○	○

## 2. DETAILED SECTION DESCRIPTIONS

### 2.1 PRINTING

#### 2.1.1 IMAGE DATA PATH

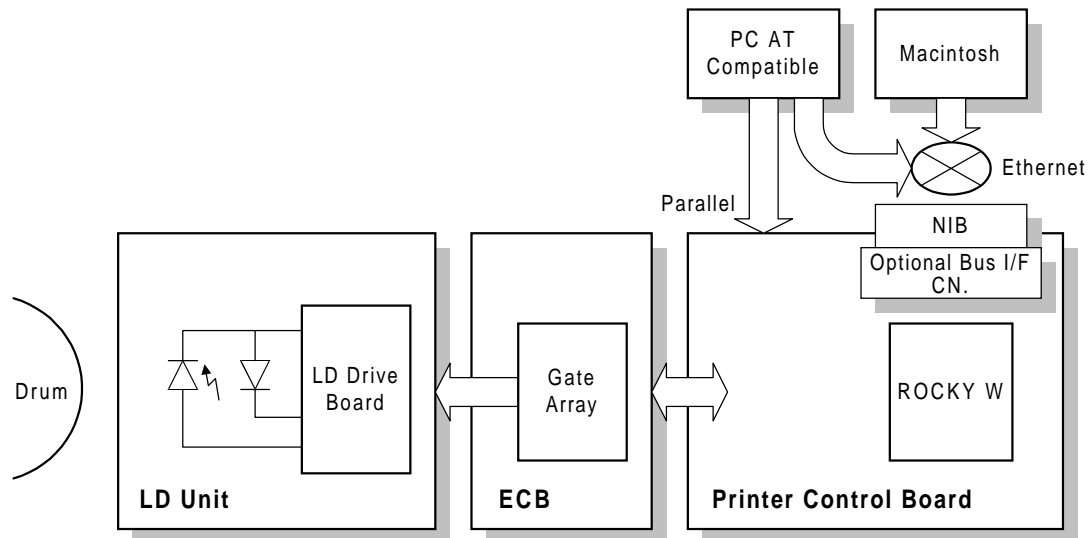

G031D502.WMF

The printer control board receives the print data from the host computer (AT compatible Windows PC or Macintosh).

- For the Stinger - P3, the printer control board has two OBI (Optional Bus Interface) connectors to connect a network interface board (NIB), RS232C interface, or HDD unit.
- For the Stinger - P4, the printer control board has one OBI connector.

The printer control board generates the print image data and sends it with commands to the ECB (Engine Control Board).

The printer control board contains the image processing ASIC (ROCKY W). The ROCKY W ASIC controls the image processing, IEEE1284 interface, DRAM, edge smoothing, and toner saving. (ASIC: Application Specific Integrated Circuit)

The ECB contains a gate array. The gate array controls LD print timing control and the serial interface to the printer control board.

Finally, the ECB sends the video data to the LD drive board.

### 2.1.2 PRINTER CONTROL BOARD

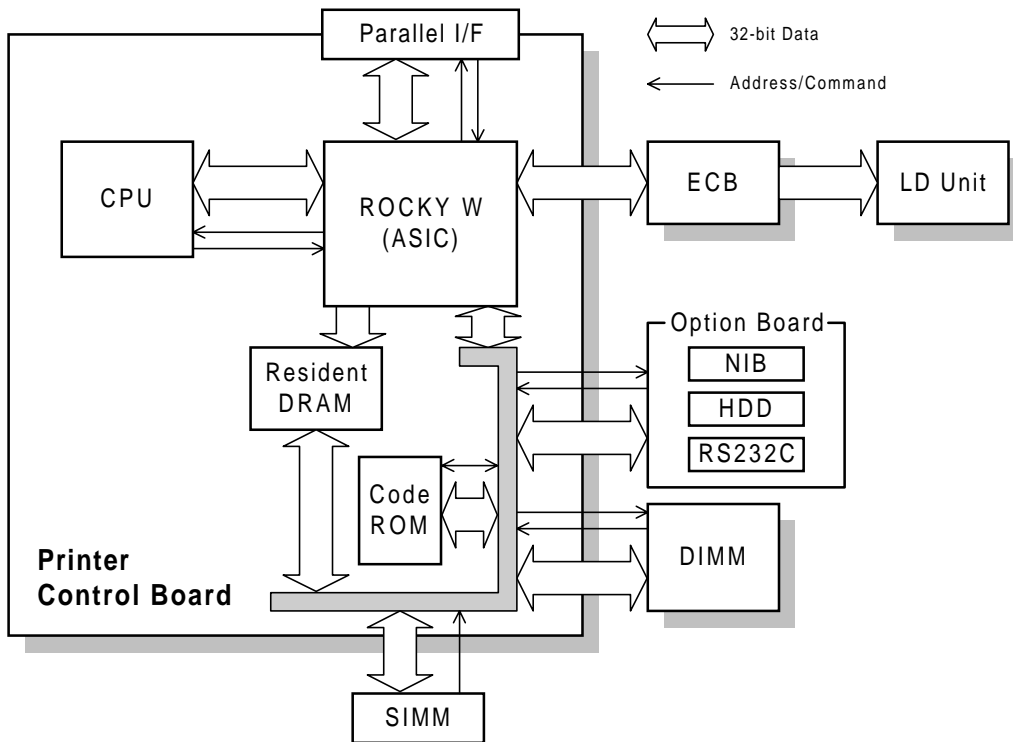

G031D503.WMF

The printer control board receives the print data from the computer through the parallel cable or network interface board.

The printer control board contains the CPU (which is a 64-bit RISC processor), the ROCKY W ASIC, 8 MB of resident DRAM for main memory, and a 8 MB code ROM.

A SIMM card can be installed for extra DRAM memory and a DIMM card can be connected for service purposes (firmware upgrade).

The control board controls the following to produce the print image data.

- 1) IEEE1284 parallel port interface
- 2) Control panel
- 3) Edge smoothing and toner saving
- 4) Engine control board
- 5) Interfacing with the HDD, NIB, and RS232C board.

### 2.1.3 IMAGE DATA PROCESSING

Edge smoothing and toner saving are performed by an ASIC (ROCKY W). The edge smoothing and toner saving modes can be switched on/off with the machine's control panel or the printer driver.

#### Edge Smoothing

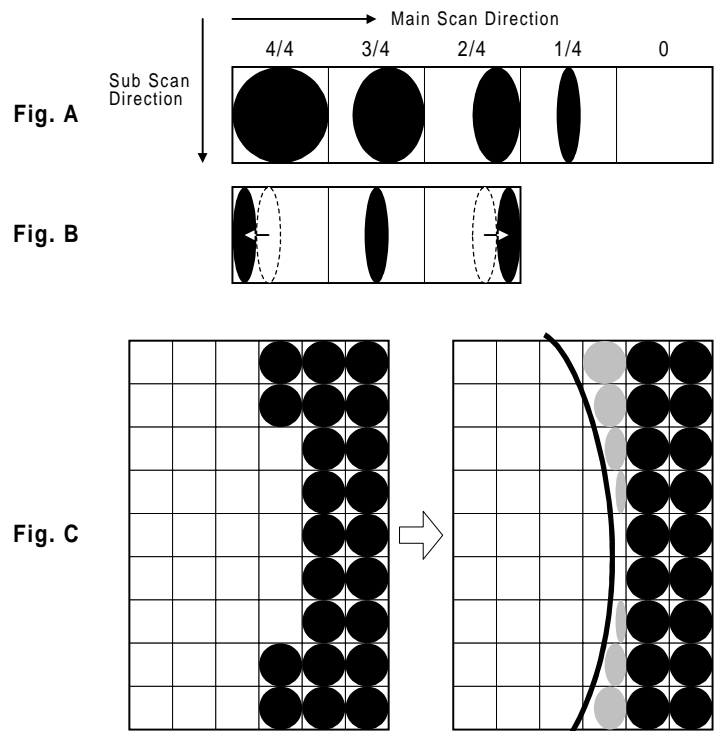

Detailed Descriptions

G031D504.WMF

Jagged edges on characters as shown in the above illustration are reduced using edge smoothing. Edge smoothing changes the laser pulse duration and position for certain pixels.

Fig. A shows the four possible pulse durations, and Fig. B shows how the laser pulse can be in one of three positions within the pixel. Fig. C shows an example of how edge smoothing is used.

Edge smoothing is not done for 1,200-dpi printing.

#### Toner Saving Mode

Toner saving is done by reducing the number of black dots in the printed image. An 8 x 8 matrix filter is used.

As a result, less toner is used to create the latent image on the drum and black areas print as gray.

The printer driver prevents edge smoothing and toner saving mode from being used at the same time.

## 2.1.4 HOST INTERFACE

### *Bi-directional Parallel Interface*

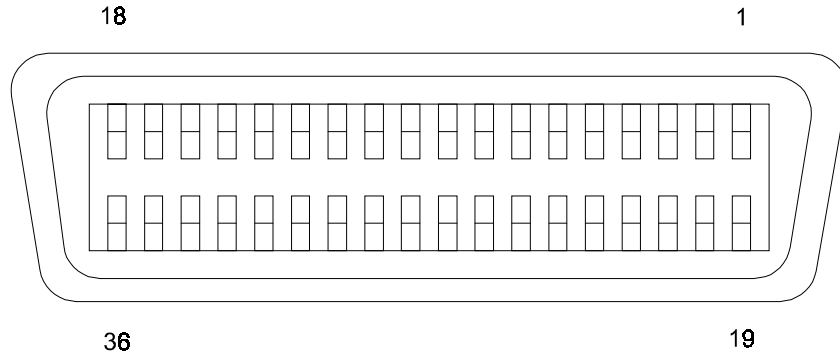

G031D505.WMF

A 36-pin bi-directional parallel interface connector (female) is used.

The bi-directional parallel interface on the controller works in three modes; Compatible, Nibble and ECP modes. These modes are standardized by IEEE 1284.

## 2.2 LASER EXPOSURE

### 2.2.1 OVERVIEW

This machine uses a laser diode to produce electrostatic images on an OPC drum. The laser diode unit converts image data from the ECB into laser pulses, and the optical components direct these pulses to the drum.

Exposure of the drum by the laser beam creates the latent image. The laser beam makes the main scan while drum rotation controls the sub scan.

	<b>Stinger - P3</b>	<b>Stinger - P4</b>
Strength of the beam output	5 mW	5 mW
Strength of the beam on the drum	0.636 mW	0.43 mW
Printing	Binary (2 bits/pixel)	Binary (2 bits/pixel)

Detailed Descriptions

There are two polygon motor speeds:

#### - Stinger - P3 -

<b>Resolution (dpi)</b>	<b>Modes</b>	<b>Motor Speed (rpm)</b>	<b>Data Frequency (MHz)</b>
600	300/600 dpi printing	22478.22	22.0926
1,200	1,200 dpi printing	22478.22	44.1851

#### - Stinger - P4 -

<b>Resolution (dpi)</b>	<b>Modes</b>	<b>Motor Speed (rpm)</b>	<b>Data Frequency (MHz)</b>
600	300/600 dpi printing	22377.62	15.0528
1,200	1,200 dpi printing	22377.62	30.1056

#### Differences between 1,200 dpi and 600 dpi printing

To produce 1,200 dpi, the machine uses a different data frequency for the main scan and a different line speed for the sub scan, compared with 600 dpi printing.

For 1,200 dpi printing, the polygon motor works at the same speed as for 600 dpi printing but the data frequency is twice as fast as in 600 dpi printing.

The paper at 1,200 dpi is fed at half the speed used for 600 dpi, as follows.

	<b>600 dpi printing</b>	<b>1,200 dpi printing</b>
Paper feed line speed	92 mm/s	46 mm/s

The beam diameter for 1,200 dpi printing is the same as for 600 dpi printing.

**2.2.2 OPTICAL PATH**

**Stinger - P3**

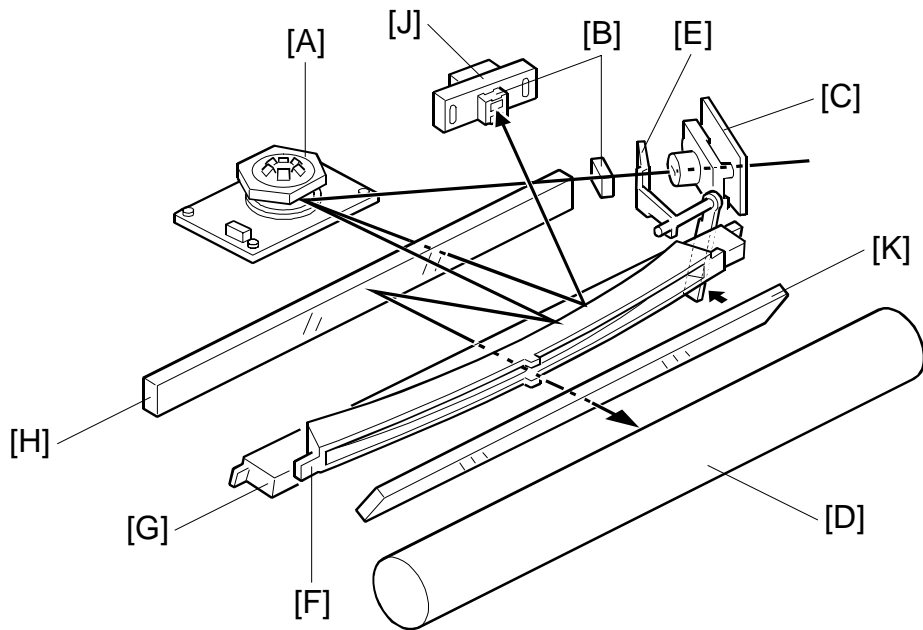

G031D506.WMF

**Stinger - P4**

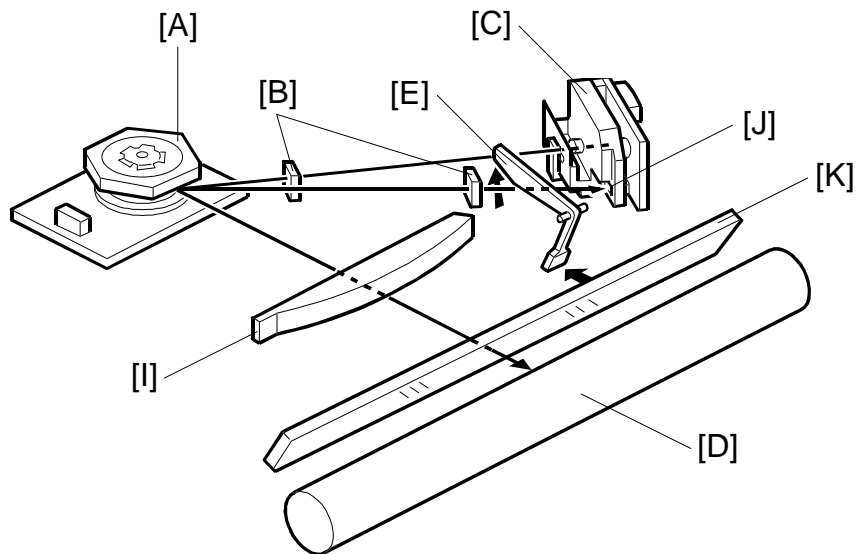

G031D507.WMF

- [A]: Polygonal Mirror
- [B]: Cylindrical Lenses
- [C]: LD Drive Board
- [D]: Drum
- [E]: LD Shutter
- [F]: F-Theta Mirror

- [G]: BTL (Barrel Toroidal Lens)
- [H]: 1st Mirror
- [I]: F-theta Lens
- [J]: Laser Synchronization Detector
- [K]: Shield Glass



The optical path from the laser diode to the drum is shown on the previous page. The LD drive board [C] outputs the laser beam to the polygonal mirror [A] through the cylindrical lenses [B], which focus the laser beam.

### *Stinger - P3*

The laser beam goes to the F-theta mirror [F], 1st mirror [H] and BTL [G]. Then, the beam reaches the drum [D] through the shield glass [K].

The beam reflected by the polygonal mirror writes the pixels of the latent image on the drum. The F-theta mirror [F] ensures constant intervals between the pixels. The BTL [G] corrects for irregularities in the polygonal mirror faces.

The laser synchronization detector [J] synchronizes the start of the main scan.

### *Stinger - P4*

The Stinger - P4 has a shorter beam path than the Stinger - P3.

The beam which is reflected by the polygonal mirror goes to the F-theta lens [I]. The beam reaches the drum [D] through the shield glass [K]. The F-theta lens [I] does the functions of both the F-theta [F] mirror and the BTL [G].

The LD drive board for the Stinger - P4 contains the laser synchronization detector.

### 2.2.3 AUTO POWER CONTROL (APC)

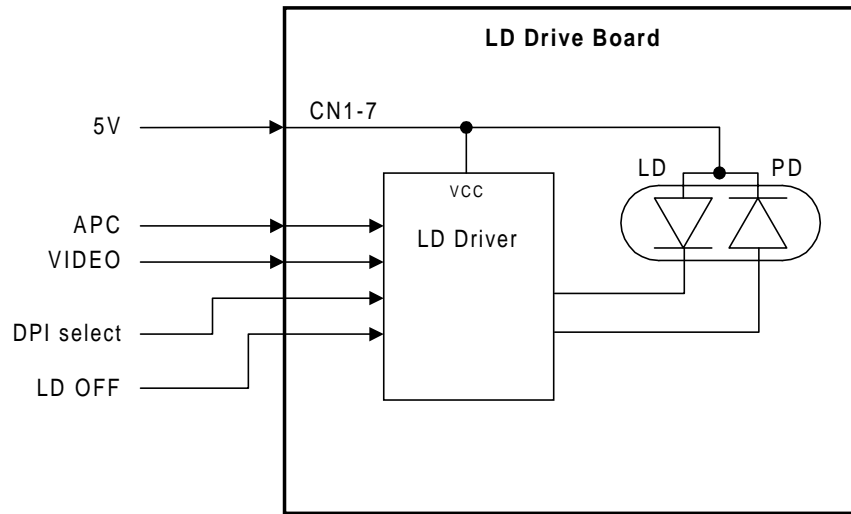

G031D508.WMF

To prevent the intensity of the laser beam from changing because of temperature, the machine monitors the laser beam with a photodiode (PD). The PD is enclosed in the laser diode. The PD passes an electrical current to the LD driver IC and this IC adjusts its output level to keep the laser diode output constant.

The laser diode power level is adjusted on the production line. Do not touch the variable resistors on the LD unit in the field.

## 2.2.4 LD SAFETY SWITCH

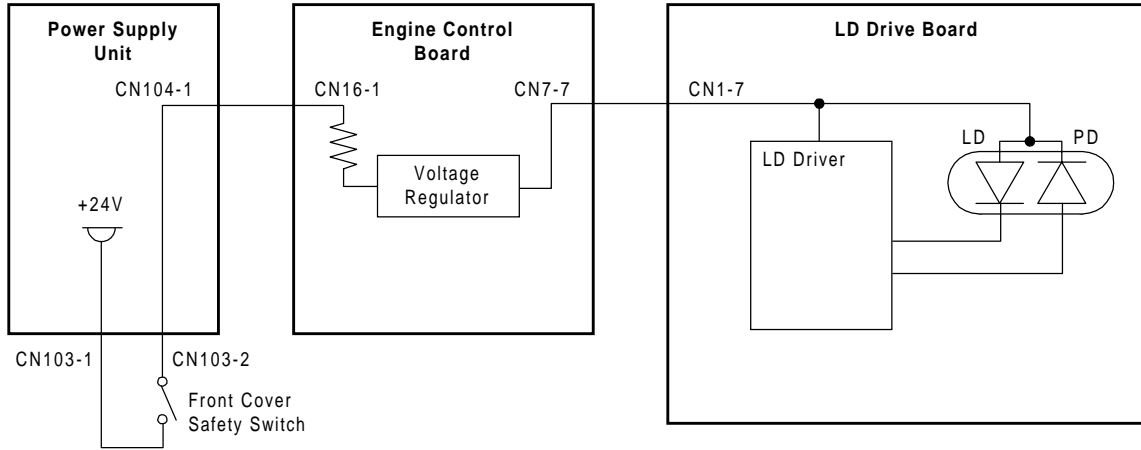

Detailed Descriptions

G031D500.WMF

### ***Front Cover Safety Switch***

To ensure that the laser beam does not inadvertently switch on during servicing, there is a safety switch located at the front cover. The switch is on the LD 24 V line.

### ***Mechanical Laser Shutter***

When the toner cartridge is removed, the laser shutter is released and this interrupts the laser beam.

## 2.3 TONER CARTRIDGE

### 2.3.1 OVERVIEW

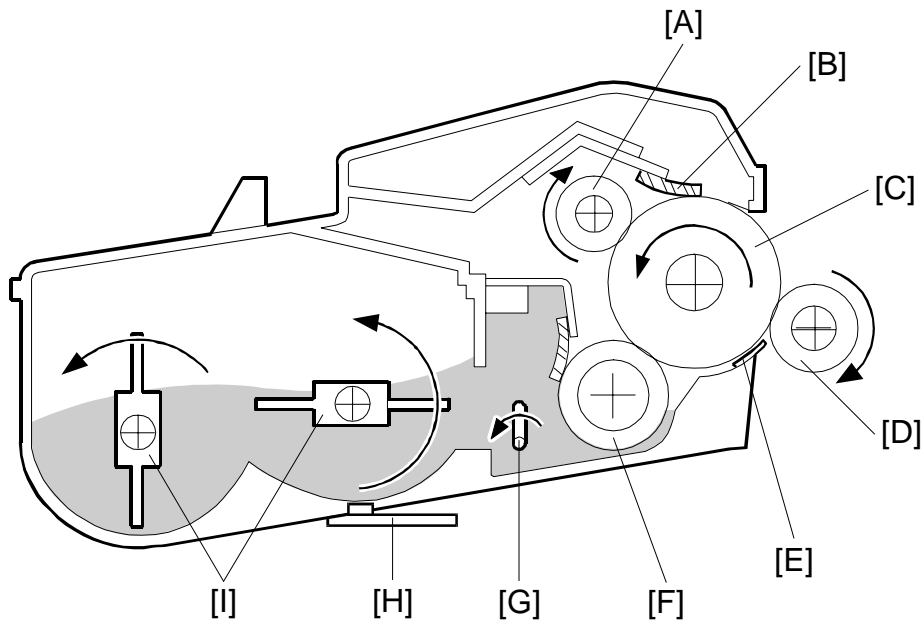

G031D509.WMF

The toner cartridge consists of the components shown above. The toner cartridge contains the OPC drum and the toner cassette, and includes the mechanisms for drum charge, development, and cleaning. The drum is 30 mm in diameter.

- |                      |                            |
|----------------------|----------------------------|
| [A]: Charge Roller   | [F]: Development Roller    |
| [B]: Cleaning Blade  | [G]: Mixing Blade          |
| [C]: OPC Drum        | [H]: Toner Near-end Sensor |
| [D]: Transfer Roller | [I]: Agitator              |
| [E]: Transfer Blade  |                            |

The main motor drives the rollers in the toner cartridge. The charge roller [A] charges the drum [C]. Monocomponent toner is used. The cleaning blade [B] cleans the drum surface.

## 2.3.2 DRIVE

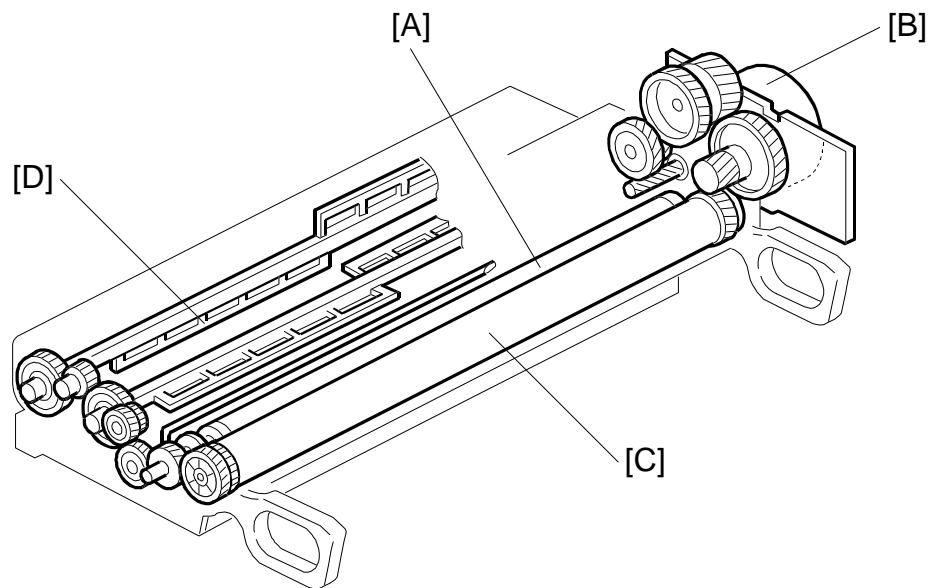

Detailed  
Descriptions

G031D510.WMF

The main motor [B] drives the drum [C], the development roller [A], and agitators [D] through a series of gears. The main motor speed is controlled by the engine control board (ECB).

When a new cartridge is installed, the machine clears the near-end condition if the toner near-end sensor detects that there is sufficient toner.

There is no counter for the toner cartridge.

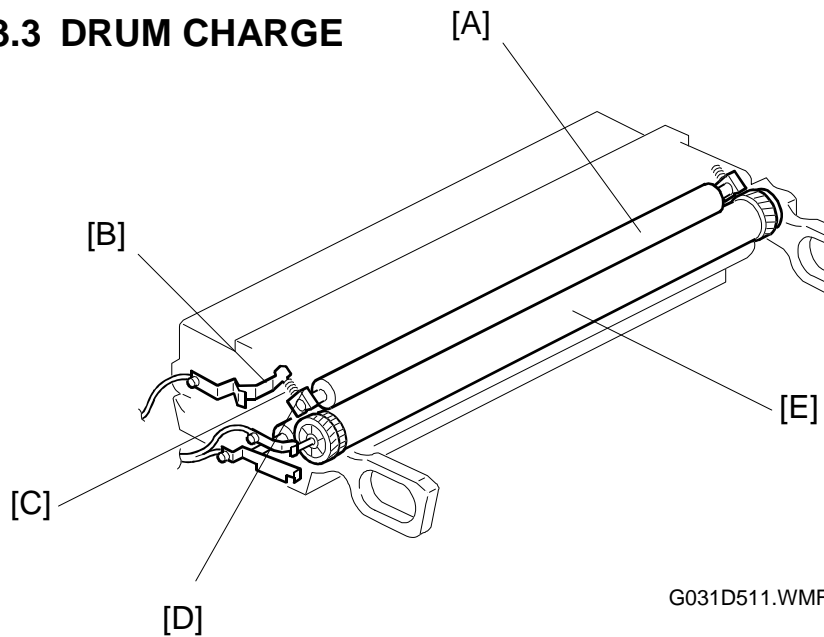
**2.3.3 DRUM CHARGE**

This machine uses a drum charge roller system instead of a scorotron corona wire system to charge the drum. The drum charge roller [A] always contacts the surface of the drum [E] because of the charge roller pressure springs [C], and gives a negative charge to the drum surface. While the drum is rotating, the drum charge roller also turns because of friction between the roller and the drum.

The drum charge roller system generates less ozone than a scorotron corona wire charge system. Due to this, there is no ozone filter in the machine.

The high voltage supply board applies voltage to the drum charge roller through the charge roller terminal [B], charge roller pressure spring [C], and the charge roller bushing [D]. Both ac and dc are applied.

Before the laser starts to write to the drum, the charge roller receives  $-600\text{Vdc}$  and  $2\text{ kV}$  peak-to-peak  $1\text{ kHz}$  ac from the high voltage supply board. This gives the drum surface a uniform negative charge of  $-600\text{ V}$ .

The dc and ac are continually supplied during the printing job. This gives the drum surface a uniform  $-600\text{ V}$  charge wherever it passes the charge roller.

At the end of the job, the dc is set to  $0\text{ V}$ , but the ac stays on. While the drum rotates past the charge roller, the ac brings the charge on the drum surface to a uniform  $0\text{ V}$ .

The toner cartridge has no cleaning pad, temperature control, or contact mechanism for the drum charge roller (the material of the drum charge roller allows a simple mechanism). The drum charge roller is part of the toner cartridge, so when the toner runs out, the drum charge roller is changed at the same time. This happens before the drum charge roller gets dirty.

## 2.3.4 DEVELOPMENT

### Overview

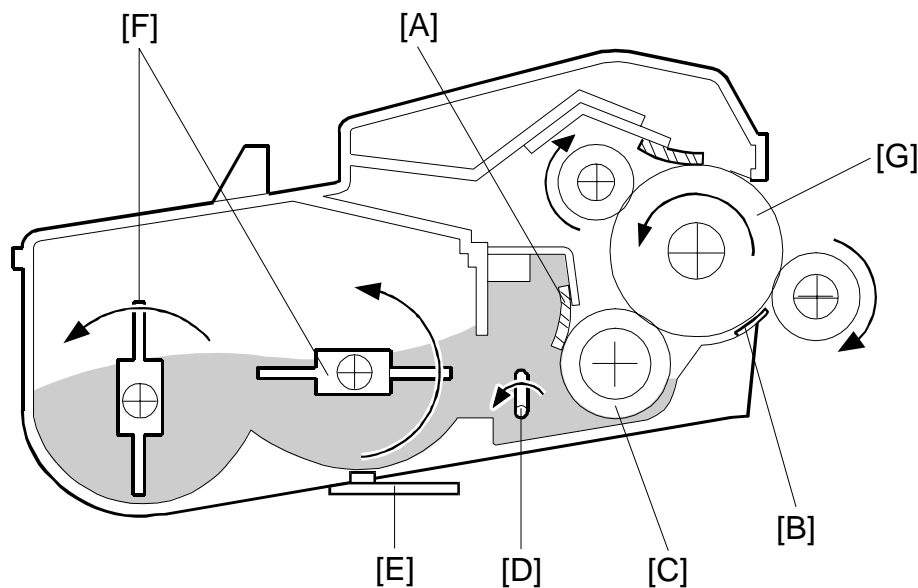

G031D509.WMF

Detailed  
Descriptions

This machine uses monocomponent toner. The Stinger - P3 has two agitators [F] in the toner cartridge (shown above). The Stinger - P4 has one agitator.

The agitator(s) [F] and the mixing blade [D] mix the toner in the toner cartridge and transport it to the development roller [C]. Friction between the transported toner and the doctor blade [A] gives the toner a negative charge.

Internal permanent magnets in the development roller attract the toner to the development roller sleeve. The doctor blade trims the toner to the desired thickness on the development roller sleeve. The development roller does not contact the drum [G]. There is a small gap between the toner on the surface of the development roller sleeve and the drum. Toner jumps across this gap to develop the latent image.

The development bias consists of ac and dc components. The ac component improves the transfer of toner.

The transfer blade [B] is charged to the same voltage as the development bias. This helps to keep the toner on the drum.

The toner near-end sensor [E] is located under the toner cartridge.

***Toner Near-End Sensor***

The toner near-end sensor monitors the toner concentration by checking the magnetic field strength.

When the reading goes down to a threshold value, the machine enters the near-end condition. There is no toner end condition (the user replaces the cartridge when the print quality has become unacceptable). The threshold value cannot be changed.

No adjustment is required after the sensor is replaced.

***Toner Supply***

The toner in the toner cartridge is mixed by the agitator(s) and mixing blade. The toner near-end sensor is not used to control toner supply. When the machine is turned on or the front cover is closed, the agitator(s) and the mixing blade rotate to mix the toner for a brief period.

***Development Bias***

The high voltage supply unit gives the development roller a charge of  $-400$  V dc and an ac component of 1.8 kVp-p 1.8 kHz ac is also used. To prevent toner from transferring to non-image areas on the drum, the development bias is different for image areas and non-image areas.



### 2.3.5 DRUM CLEANING

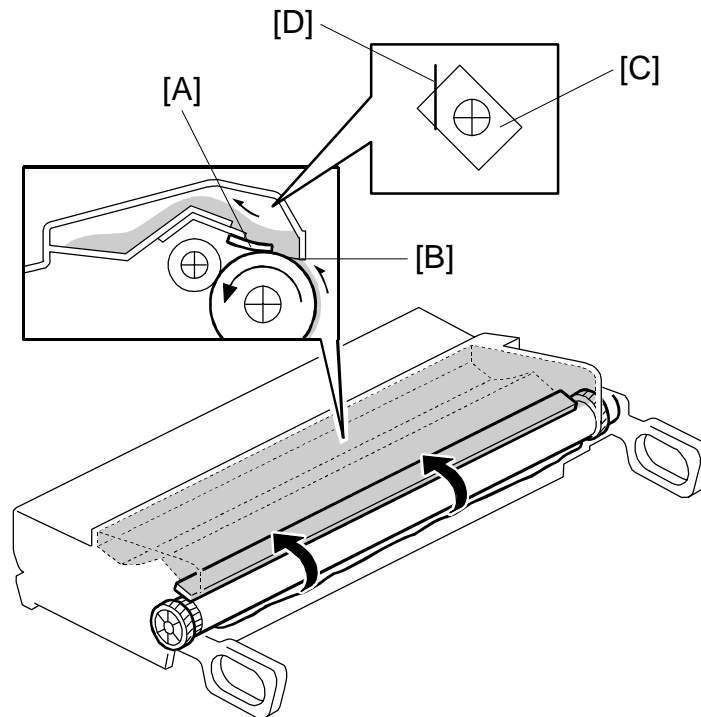

G031D512.WMF

Detailed  
Descriptions

The cleaning blade [A] removes any toner remaining on the drum after the image is transferred to the paper. The toner remaining on the drum is scraped off by the cleaning blade and transferred to the collection area. The mylar sheet [B] prevents the toner from dropping out of the cleaning unit.

The toner cartridge in the commercial toner cartridge has a toner collection coil [C] and scraper [D]. These improve the collection of waste toner.

There is no toner recycling mechanism.

## 2.4 IMAGE TRANSFER AND PAPER SEPARATION

### 2.4.1 OVERVIEW

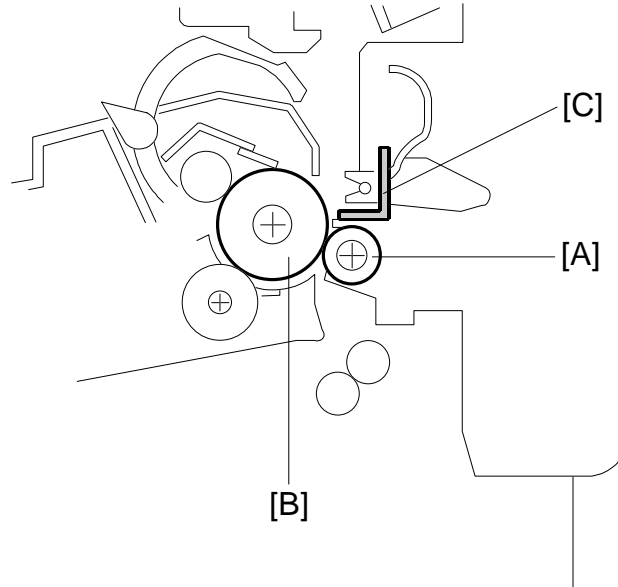

G031D513.WMF

The machine uses a transfer roller [A] which touches the surface of the drum [B].

The high voltage supply unit supplies a positive current to the transfer roller. A feedback circuit inside the machine automatically keeps the transfer current constant.

The current depends on the paper size. For A3 paper in the Stinger - P3,  $7\mu\text{A}$  is supplied, and for A4 paper in the Stinger - P4,  $6\mu\text{A}$  is supplied (for 600 dpi resolution in both of these cases).

The transfer roller attracts the toner from the drum onto the paper.

Drive from the drum through a gear drives the transfer roller.

The discharge plate [C] and the curvature of the drum helps the paper to separate from the drum. The discharge plate is connected to ground.

## 2.4.2 TRANSFER ROLLER CLEANING

If the paper size is smaller than the printed image, or if a paper jam occurs during printing, toner may be transferred to the roller surface. To prevent this toner from transferring to the back side of the printouts, the transfer roller has to be cleaned before the next printing run.

During transfer roller cleaning, the high voltage supply unit supplies a negative cleaning bias to the transfer roller. The negatively charged toner on the transfer roller is then transferred back to the drum. Then a positive cleaning bias is applied to the transfer roller to push back to the drum any toner which was positively charged by the transfer roller.

The machine goes through the cleaning mode in the following conditions:

- After a printer jam has been cleared.
- Just after the power is switched on.
- After 10 sheets of paper have been printed and the print job has finished.

## 2.5 PAPER FEED

### 2.5.1 OVERVIEW

#### *Stinger - P3*

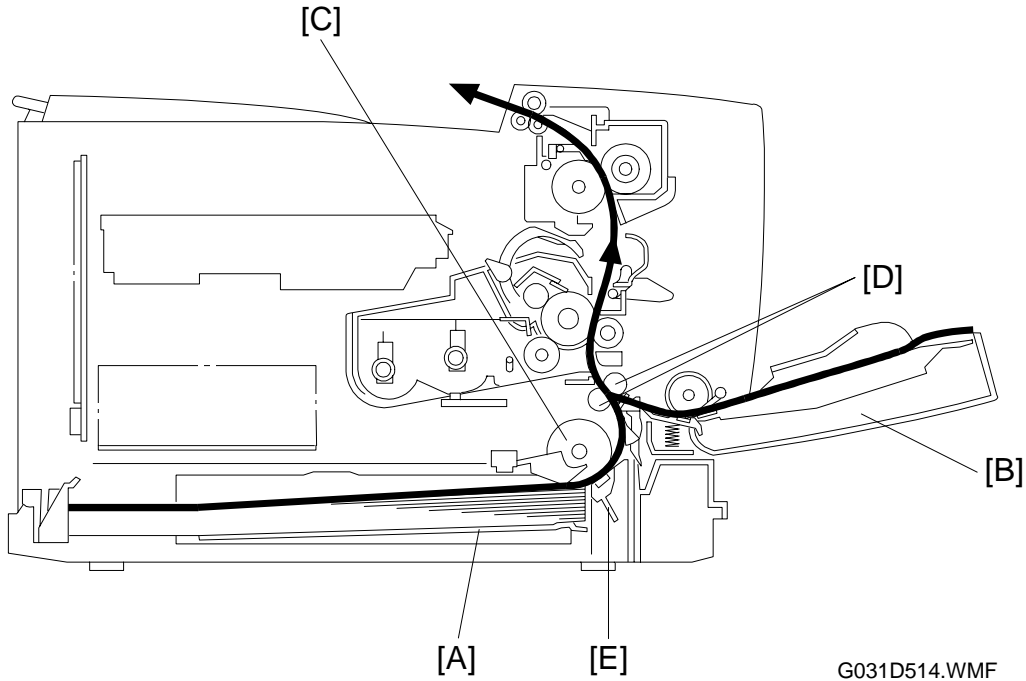

G031D514.WMF

There is a paper tray [A] and a by-pass tray [B].

The paper tray holds 250 sheets. The by-pass tray can hold 100 sheets of paper. The paper feed roller [C] drives the top sheet of paper from the paper tray to the registration rollers [D].

The paper tray has a friction pad [E] which allows only one sheet to feed at a time.

When the paper tray is closed after the paper is loaded, the paper size actuator (behind the paper size indicator, which is located at the front right of the tray) pushes the tray paper size switch. This informs the CPU what paper size is loaded in the tray and that the tray is in place.

The tray can be extended manually to hold paper longer than A4/Letter size.

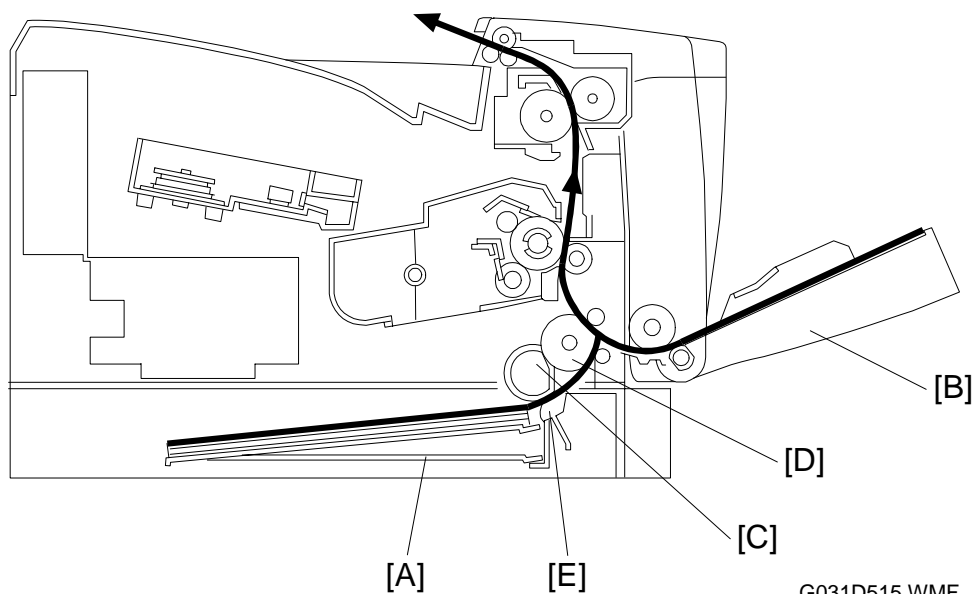
**Stinger - P4**Detailed  
Descriptions

There is a paper tray [A] and a by-pass tray [B].

The paper tray holds 250 sheets. The by-pass tray can hold 100 sheets of paper. The paper feed roller [C] drives the top sheet of paper from the paper tray to the relay roller [D]. Then the relay roller feeds the paper to the registration area.

The paper tray has a friction pad [E] which allows only one sheet to feed at a time.

This machine does not have a paper size switch. So, before printing, the user must register the paper size in the paper tray at the printer's operation panel.

The built-in tray can only hold A4 or letter size paper.

## 2.5.2 PAPER TRAY

### *Stinger - P3*

#### *Tray Extension*

The tray can be extended manually to hold paper longer than A4/Letter size. The default setting of the tray length is for short paper. To use longer paper, release the catches [A] at both sides, then extend the tray and re-lock the catches.

The paper sizes in the table given below can be used.

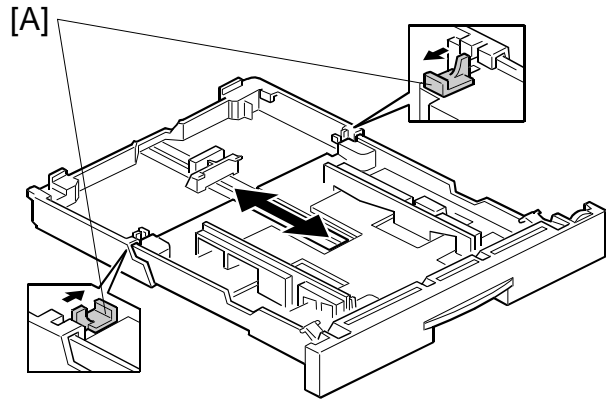

G031D516.WMF

Tray mode	Possible Paper Sizes
Short (default)	A5 Landscape, B5 Landscape, A4 Landscape, 7 1/4" x 10 1/2" Landscape, 8 1/2" x 11" Landscape, 8 1/2" x 11" Portrait, A4 Portrait
Long	8 1/2" x 13" Portrait, 8" x 13" Portrait, 8 1/4" x 13" Portrait, 8 1/2" x 14" Portrait, B4 Portrait, A3 Portrait, 11" x 17" Portrait

#### *Bottom Plate Lift*

The tray bottom plate [B] is connected to the cassette arms [C] by springs [D]. When the cassette is put in the machine, the slopes of the guide blocks [E] on the machine lift the cassette arms up and the springs keep the stack of paper at the correct height. When the paper is used up, the springs pull the tray bottom plate up as shown in the picture.

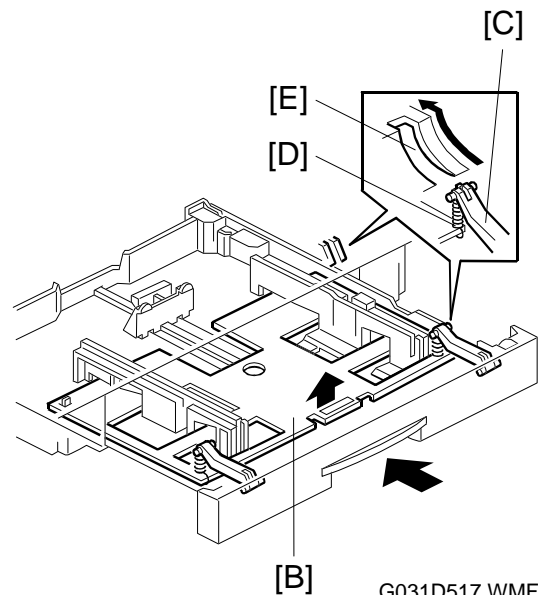

G031D517.WMF

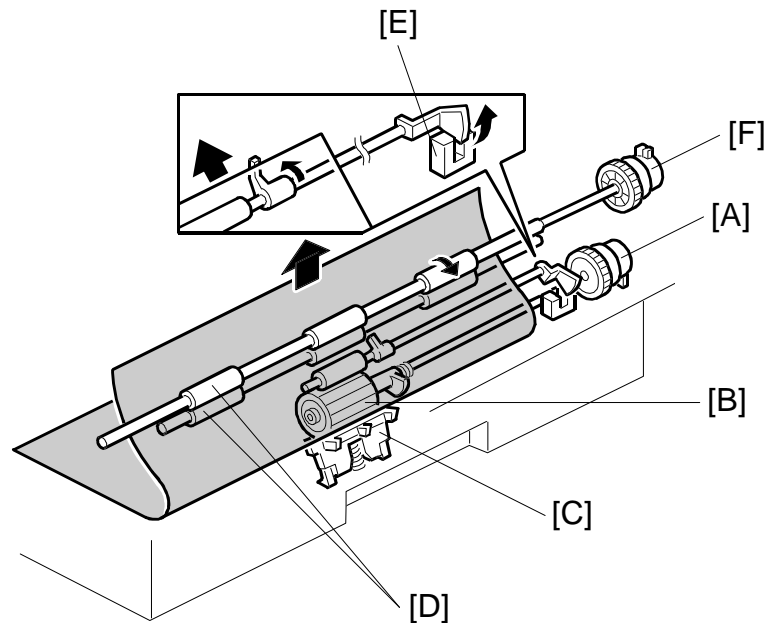
*Paper Feed Drive*

G031D518.WMF

The main motor drives the pick-up and feed mechanism. The tray paper feed clutch [A] transfers drive from the main motor to the paper feed roller [B].

This machine uses a feed roller and friction pad mechanism. The friction pad [C] only allows the top sheet to feed. Therefore, during paper feed, the top sheet of paper is separated from the stack and fed to the registration rollers [D].

When the paper actuates the registration sensor [E], the tray paper feed clutch turns off. When the paper reaches a certain position, the registration clutch [F] turns on to transfer drive from the main motor to the registration rollers. Then the registration rollers feed the paper to the transfer area.

**Paper Size Detection**

The paper size switch [A] includes three sensors (microswitches). The sensors are actuated by actuators on a dial [B] behind the paper size indicator plate.

Each paper size has its own actuator, with a unique combination of notches. To determine the paper size, the CPU reads which switches have been turned off by the actuator.

The CPU disables paper feed from a tray if the paper size cannot be detected. If the paper size actuator is broken, or if there is no tray installed, the printer control board recognizes that the paper tray is not installed.

When the paper size actuator is at the "\*" mark, the paper tray can be set up to accommodate one of a wider range of paper sizes by using a user tool at the machine's operation panel.

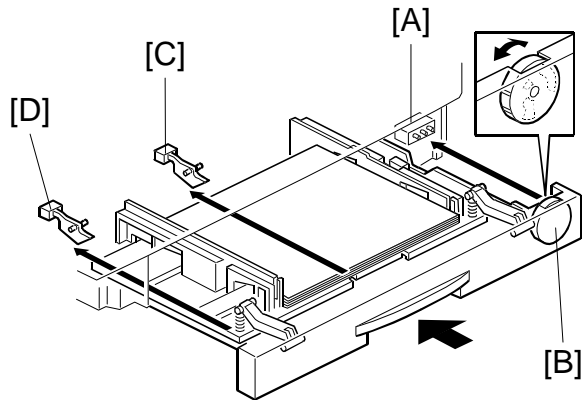

G031D519.WMF

Models		Switch Location		
North America	Europe	Left	Center	Right
8 1/2" x 14" Portrait	A5 Landscape	On	On	On
A4 Landscape	A4 Landscape	On	Off	Off
8 1/2" x 11" Portrait	A4 Portrait	On	On	Off
*	*	Off	On	On
8 1/2" x 13" Portrait	8 1/2" x 13" Portrait	Off	On	Off
8 1/2" x 11" Landscape	8 1/2" x 11" Landscape	On	Off	On
11" x 17" Portrait	A3 Portrait	Off	Off	On

On: Pushed Off: Not Pushed

**Paper End Detection**

When the paper tray runs out of paper, the feeler of the tray paper end sensor drops into the cutout in the tray bottom plate and this activates the paper end sensor [C].

**Paper Near End Detection**

When almost 50 sheets are left on the tray, the tray bottom plate pushes up the feeler of the tray paper near end sensor [D]. However, there is no indication on the printer's operation panel; the signal is only for use by the host computer.



**Stinger - P4**

**Bottom Plate Lift**

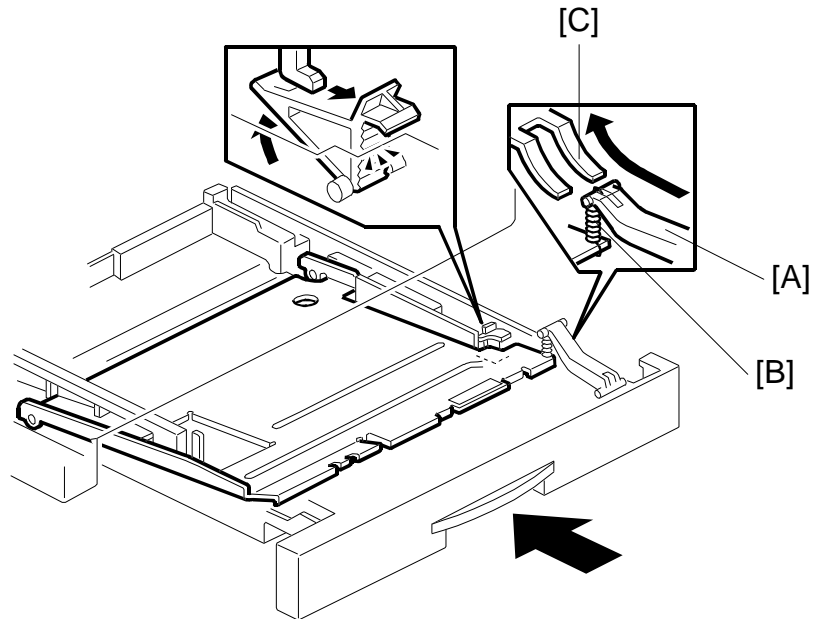

Detailed  
Descriptions

G031D520.WMF

The tray bottom plate is connected to the cassette arm [A] by the spring [B]. When the cassette is put in the machine, the slope of the guide block [C] on the machine lifts the cassette arm up and the spring lifts up the bottom plate.

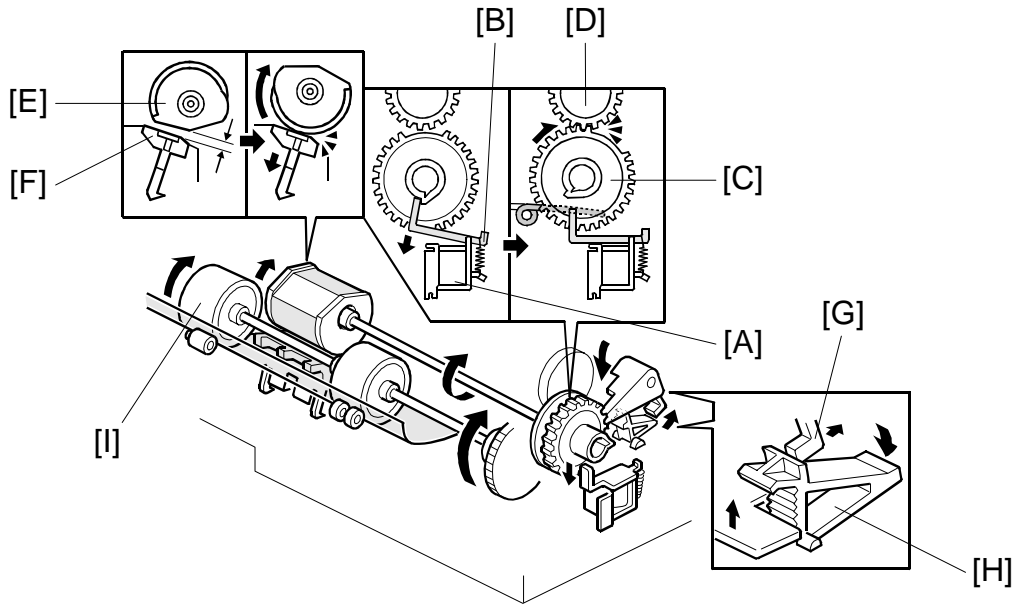
*Paper Feed Drive*

G031D521.WMF

The main motor drives the pick-up and feed mechanism through the paper pick-up drive gear [D].

To pick up paper, the tray paper feed solenoid [A] turns on and the gear stopper [B] comes off the paper feed roller gear [C]. This gear does not move immediately, because the gap in the teeth prevent it from engaging the drive gear [D]. It is first turned clockwise by a spring until its teeth engage with the drive gear, which now drives the paper feed roller [E].

At the same time, the cam behind the paper feed roller gear moves the stopper release lever [G], and this releases the bottom plate stopper [H]. The bottom plate can then lift the top of the paper stack to the correct height for paper feed.

This machine uses a feed roller and friction pad mechanism. The friction pad [F] only allows the top sheet to feed to the relay roller [I].

After one turn, the paper feed roller gear stops because the part of the gear without teeth is now back at the starting position, opposite the pick-up drive gear. The gear stopper and bottom plate stopper also return to their previous positions

Then the relay rollers feed the paper to the transfer area.

**NOTE:** If the gear stopper comes off the paper feed roller gear as a result of shock or vibration and paper is placed in the tray, the machine starts to feed paper as soon as it is turned on. To fix this problem, remove all paper from the paper tray then turn on the machine.

*Paper End Detection*

This is the same as for the Stinger - P3. There is no near-end detection.

## 2.5.3 BY-PASS TRAY

### *Stinger - P3*

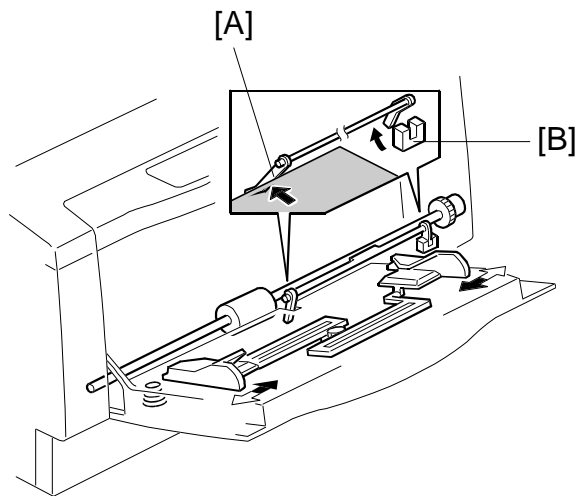

G031D522.WMF

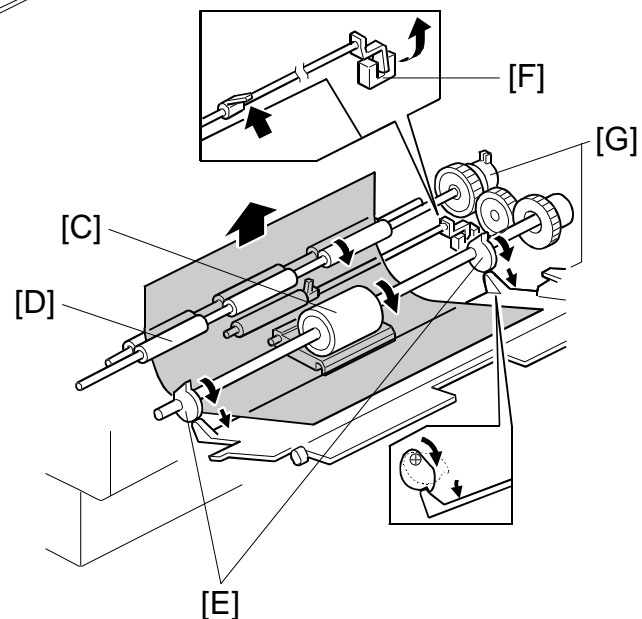

G031D523.WMF

When paper is placed on the tray, the by-pass tray paper feeler [A] is pushed up and the actuator leaves the by-pass tray paper sensor [B].

After image processing in the printer control board, the CPU energizes the by-pass feed solenoid and the by-pass feed roller [C] starts to feed paper to the registration roller [D]. The by-pass feed roller has two cams [E] and these cams release the by-pass tray bottom plate to press the stack of paper against the by-pass feed roller.

This machine uses a feed roller and friction pad mechanism, with drive from the main motor transmitted when the by-pass feed clutch turns on. The friction pad only allows the top sheet to feed to the registration rollers.

When the paper leading edge activates the registration sensor [F], the registration clutch [G] turns on.

**Stinger - P4**

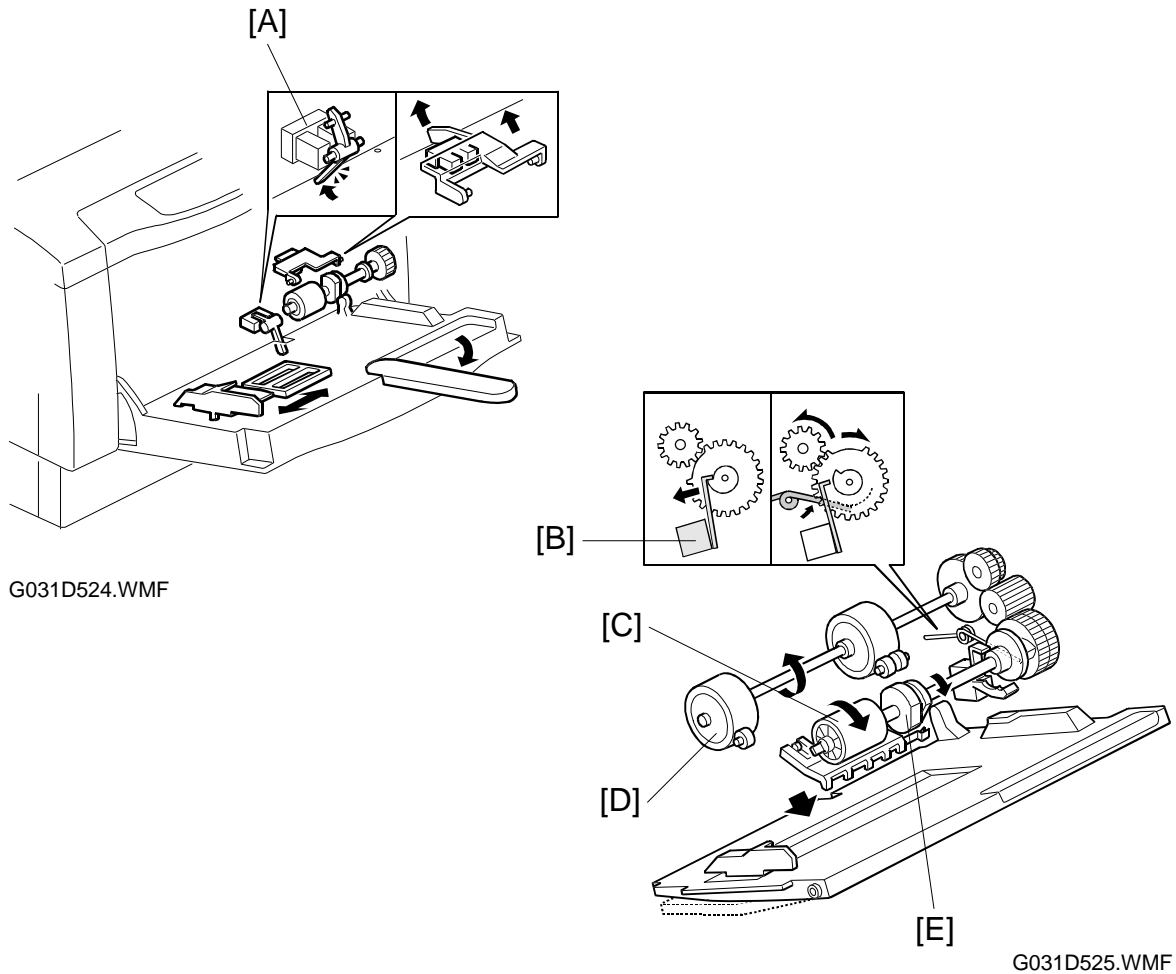

G031D524.WMF

G031D525.WMF

When paper is placed on the tray, the by-pass tray paper sensor [A] activates.

After image processing in the printer control board, the CPU energizes the by-pass feed solenoid [B] and the by-pass feed roller [C] starts to feed paper to the relay roller [D]. The by-pass feed roller cam [E] releases the by-pass tray bottom plate to press the stack of paper against the by-pass feed roller.

This machine uses a feed roller and friction pad mechanism, with drive from the main motor transmitted when the by-pass feed clutch turns on. The friction pad only allows the top sheet to feed to the relay roller.

## 2.5.4 PAPER REGISTRATION

### *Stinger - P3*

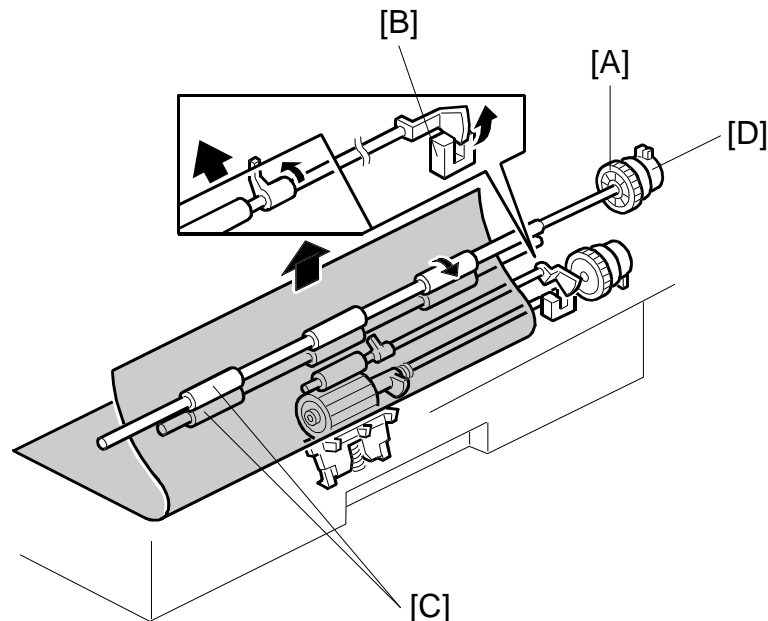

G031D518.WMF

Main motor rotation is transmitted to the registration clutch gear [A].

The registration sensor [B] is just before the registration rollers [C].

When the paper leading edge activates the registration sensor, the registration clutch [D] turns off and the registration rollers stop turning. However, the tray paper feed roller clutch stays on for a bit longer. This delay allows time for the paper to press against the registration rollers and buckle slightly to correct skew. The registration clutch energizes at the proper time to align the paper with the image on the drum. The registration rollers feed the paper to the image transfer section.

The registration sensor is also used for paper misfeed detection.

**Stinger - P4**

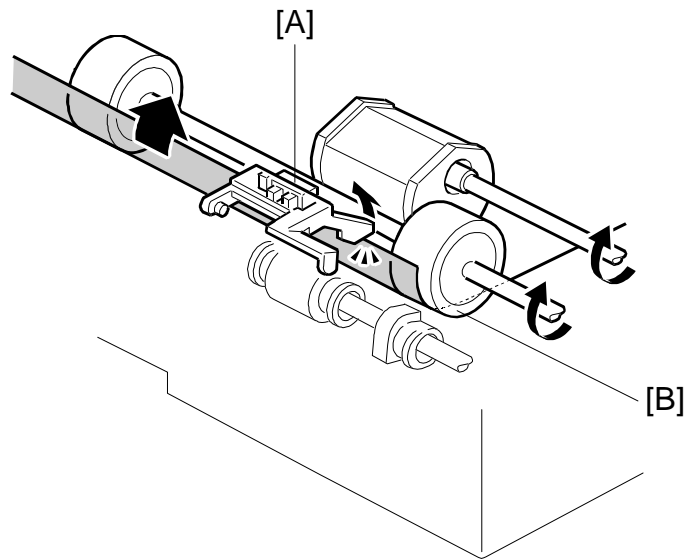

G031D526.WMF

The registration sensor [A] is just after the relay roller [B]. However, this machine has no registration roller.

A certain time after the paper leading edge activates the registration sensor, the CPU starts to write the latent image on the drum.

The registration sensor is also used for paper misfeed detection.

## 2.6 IMAGE FUSING

### 2.6.1 OVERVIEW

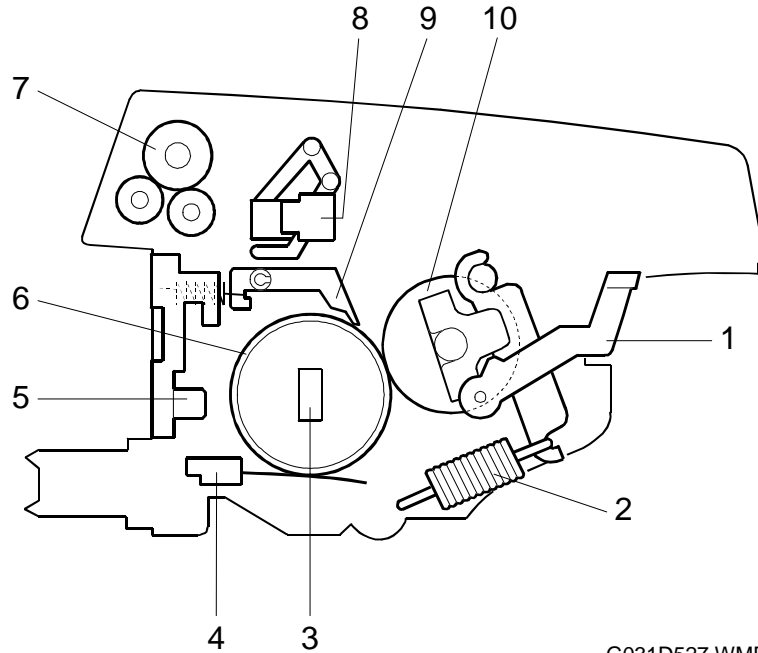

G031D527.WMF

Detailed  
Descriptions

The fusing unit consists of the following parts.

- |   |                         |
|---|-------------------------|
| 1. Pressure Roller Release Lever              | 6. Hot Roller           |
| 2. Pressure Spring                            | 7. Exit Roller          |
| 3. Fusing Lamp                                | 8. Fusing Exit Sensor   |
| 4. Fusing Thermistor                          | 9. Hot Roller Strippers |
| 5. New Fusing Unit Detector (Stinger P3 only) | 10. Pressure Roller     |

**2.6.2 FUSING**

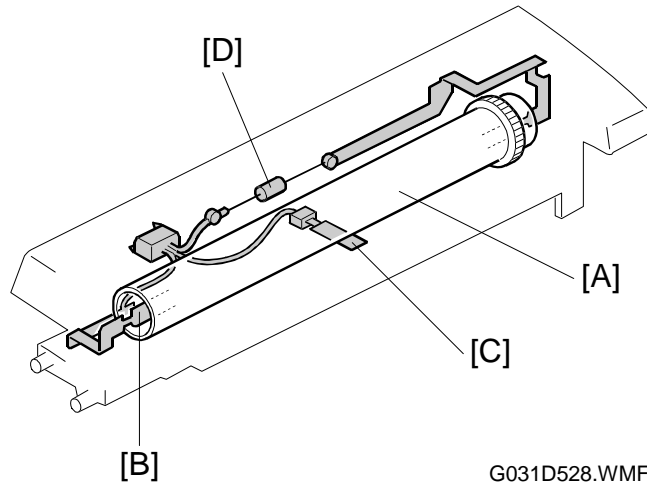

After the image has been transferred, the paper enters the fusing unit. The image is fused to the paper by applying heat and pressure through the combination of hot roller [A], the fusing lamp [B], and the pressure roller.

The CPU monitors the hot roller temperature through the fusing thermistor [C] that is in contact with the hot roller surface. The thermofuse [D] protects the fusing unit from overheating.

**2.6.3 FUSING UNIT DRIVE**

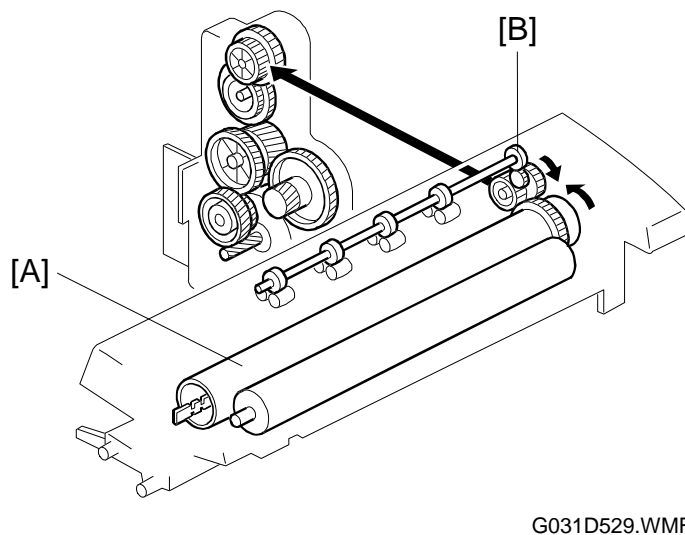

The main motor drives the hot roller [A] through a train of gears. The hot roller drives the exit roller [B] through a gear.



### 2.6.4 PRESSURE ROLLER/PAPER EXIT

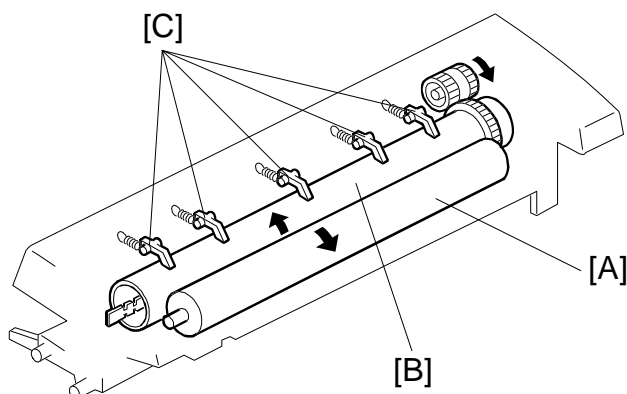

G031D530.WMF

Detailed  
Descriptions

During printing, the pressure roller [A] is pressed against the hot roller [B] by springs.

The hot roller strippers [C] separate the paper from the hot roller and direct it to the exit roller. Then the exit roller feeds the paper to the paper tray.

### 2.6.5 FUSING UNIT DRIVE RELEASE

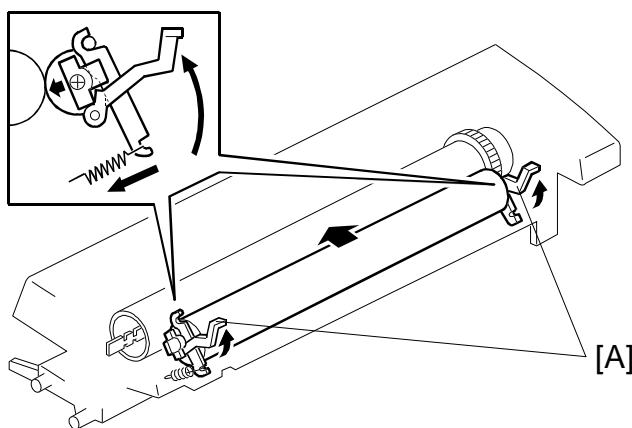

G031D531.WMF

When the pressure roller release levers [A] are pushed down, the pressure roller moves away so that jammed paper can be removed.

### 2.6.6 NEW FUSING UNIT DETECTION (STINGER - P3 ONLY)

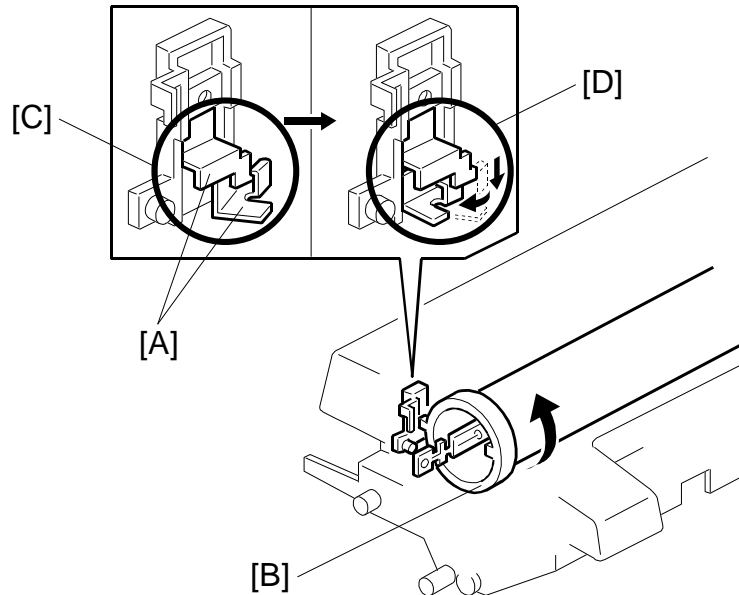

G031D532.WMF

The fusing unit in the Stinger - P3 maintenance kit has this detection mechanism (the fusing unit obtained as a service part does not). When the fusing unit has been replaced, the CPU detects the new unit and automatically removes the "Replace Maintenance Kit" from the display and resets the maintenance counter.

**NOTE:** The Stinger - P4 doesn't have this mechanism, so after replacing the fusing unit, clear the "Replace Maintenance Kit" status using the "User Menu – Maintenance – PM Clear" procedure.

There are two terminals [A] at the rear left side of the fusing unit. Before installation, these terminals are in contact [C]. When the machine is turned on after installing the new fusing unit, the projection on the ring [B] attached to the left end of the hot roller disconnects the terminals [D]. When the CPU detects the change in the signal from these terminals from 'shorted' to 'open', the CPU recognizes that a new fusing unit has been installed and it then resets the counter and the display.

## 2.6.7 FUSING TEMPERATURE CONTROL

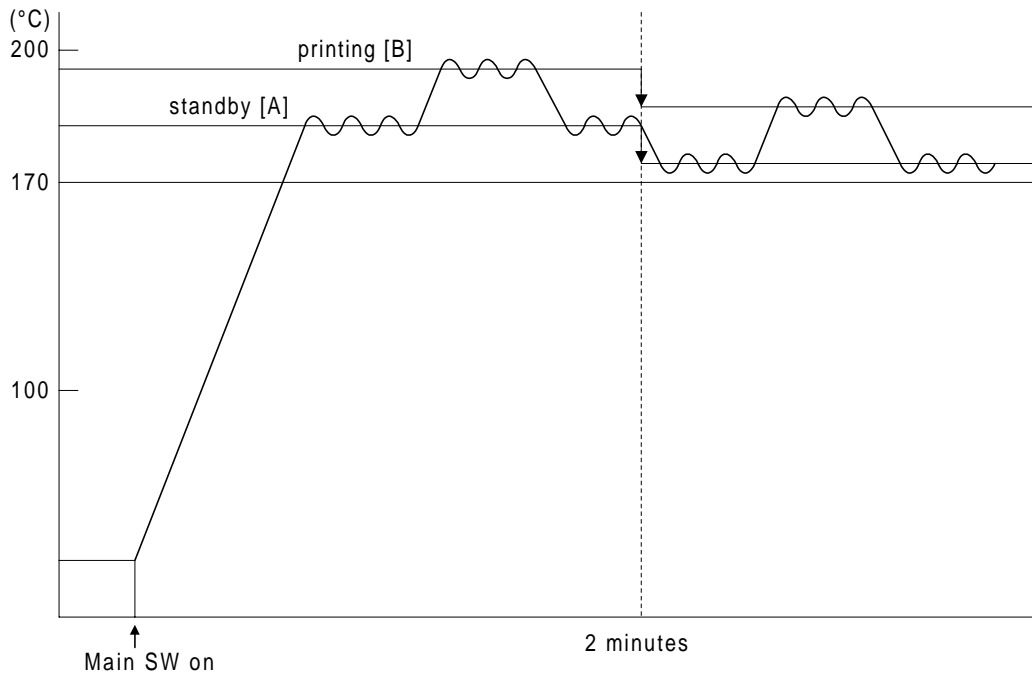

Detailed  
Descriptions

G031D533.WMF

When the main switch turns on, the CPU turns on the fusing lamp. When the thermistor detects the 'ready to print' temperature (170°C), the machine can start to print at any time. The lamp stays on until the thermistor detects the standby temperature [A]. Then, the CPU maintains this temperature using on-off control. To start printing, the CPU raises the temperature to the printing temperature [B] and maintains it as shown on the next page.

In energy saver mode, the fusing lamp is off.

The CPU controls the temperature as shown in the following tables to keep the fusing lamp at the appropriate temperature for each condition.



**Stinger - P3**

Condition		Power on → Within 2 minutes	After 2 minutes
Ready to print		170°C	170°C
Standby mode		185°C	175°C
Printing (600 dpi)	Normal paper	195°C	185°C
	Thick paper (> 155 g/m <sup>2</sup> , 41 lb)	195°C	195°C
Printing (1,200 dpi)	Normal paper	165°C → 160°C *	160°C → 155°C *
	Thick paper (> 155 g/m <sup>2</sup> , 41 lb)	165°C	160°C

\*: After 26 seconds at 1,200 dpi using normal paper, the temperature is reduced.

**Stinger - P4**

Condition		Power on → Within 2 minutes	After 2 minutes
Ready to print		170°C	170°C
Standby mode		175°C	165°C
Printing (600 dpi)	Normal paper	185°C	175°C
	Thick paper (> 155 g/m <sup>2</sup> , 41 lb)	185°C	185°C
Printing (1,200 dpi)	Normal paper	150°C → 145°C *	145°C → 140°C *
	Thick paper (> 155 g/m <sup>2</sup> , 41 lb)	150°C	145°C

\*: After 15 seconds at 1,200 dpi using normal paper, the temperature is reduced.

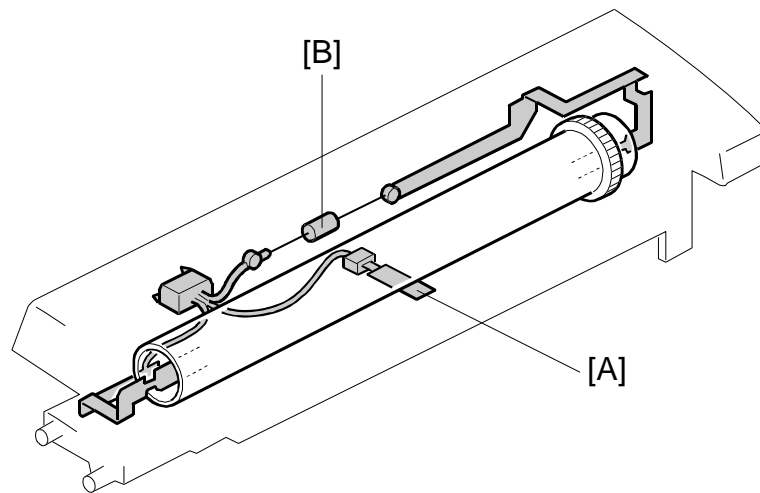

G031D528.WMF

Detailed Descriptions

The fusing temperature is controlled using the fusing thermistor [A].

The CPU checks the output from the fusing thermistor once a second. The CPU compares the current and previous temperature, then decides the power-on ratio for the next second. To maintain the target temperature, the CPU controls the fusing lamp power-on ratio as shown in the following table.



Previous minus Current	Current minus Target				
	Over -3°C	Within -3°C	0	Within +3°C	Over +3°C
Over -3°C	100%	60%	60%	60%	0%
Within -3°C	100%	60%	60%	40%	0%
0	100%	60%	60%	40%	0%
Within +3°C	100%	60%	60%	40%	0%
Over +3°C	100%	60%	0%	0%	0%

Ratio (%): The proportion of time that the fusing lamp power is on

### 2.6.8 OVERHEAT PROTECTION

If the hot roller temperature becomes greater than 230°C for more than 1 second, the CPU cuts off the power to the fusing lamp. At this time, SC543 will be generated.

Even if the thermistor overheat protection fails, there is a thermofuse in series with the common ground line of the fusing lamp. If the temperature of the thermofuse [B] reaches 169°C, the thermofuse opens, removing power from the fusing lamp. At this time, the printer stops operating.

## 2.6.9 ENERGY SAVER MODE

When the machine is not used, the energy saver feature reduces power consumption by switching off the fusing lamp.

### *Entering Energy Saver Mode*

Energy saver mode starts after the machine has been idle for a certain time. This time is specified by the user. The following choices are available.

- Off (energy saver mode never activates)
- 15 minutes
- 30 minutes (default)
- 1 hour
- 2 hours
- 3 hours

This feature is adjusted using the Job Control menu at the printer's operation panel.

**NOTE:** When the machine is in energy saver mode, the CPU turns off the fusing lamp. Therefore, the time from the print start command to the start of printing is longer than in normal standby mode.

### *Leaving Energy Saver Mode*

The machine leaves energy saver mode when one of the following happens.

- Print command received from the PC
- Front cover opened and closed
- Paper tray pulled out and replaced
- Any operation panel keys pressed

## 2.7 COVER OPEN DETECTION

### 2.7.1 FRONT COVER LOCK

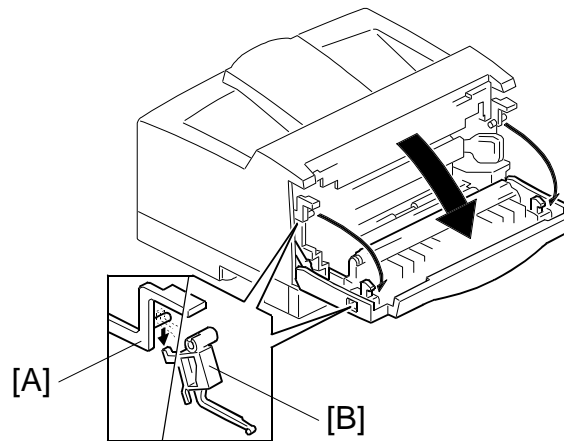

G031D534.WMF

There is a hook [A] at the front and rear of the machine. When the front cover is closed, the hooks catch the lock levers [B].

To open the front cover, push the cover open levers at both sides of the front cover.

### 2.7.2 FRONT COVER SAFETY SWITCH

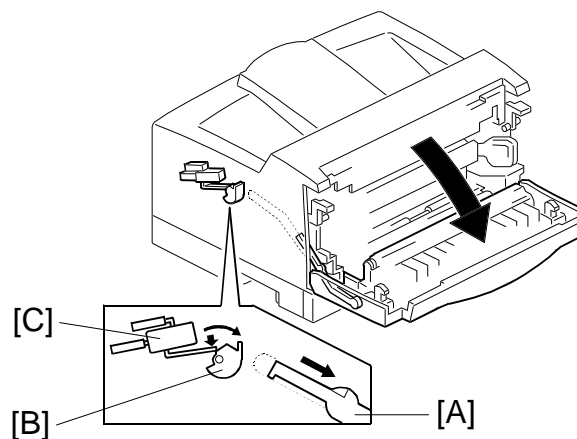

G031D535.WMF

When the user opens the front cover, the safety switch release lever [A] moves and the safety switch release cam [B] rotates as shown in the picture. Then the front cover safety switch [C] turns off.

If the front cover safety switch turns off, the +24V line from PSU to ECB is cut. As a result, the power for the LD driver is cut.

### 2.7.3 REMOVING THE FUSING UNIT

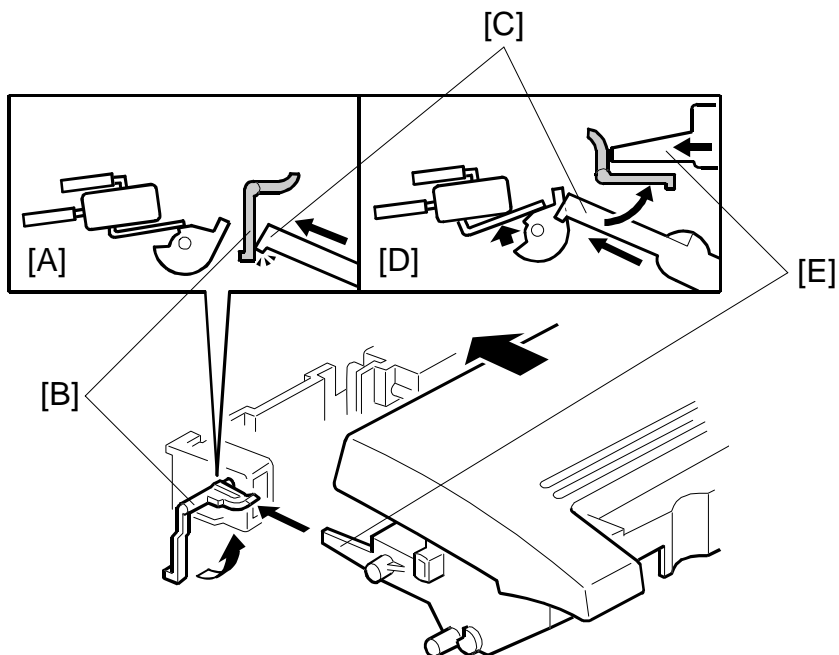

G031D536.WMF

When the fusing unit is not in the machine [A], the stopper [B] blocks the safety switch release lever [C]. Therefore, the front cover cannot be closed.

When the fusing unit is installed properly [D], the projection on the fusing unit [E] lifts up the stopper. Therefore, the safety switch release lever can pass and the front cover can be closed.



## 2.8 ENGINE CONTROL BOARD

### 2.8.1 PCB LAYOUT

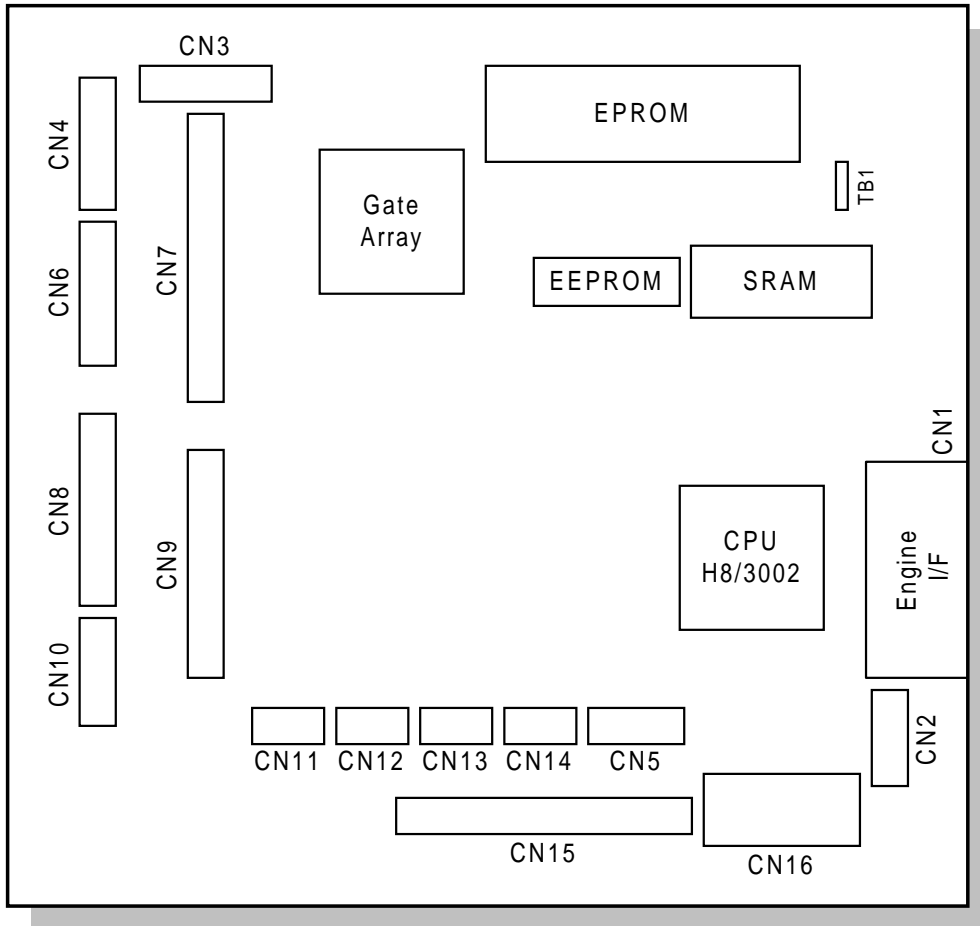

Detailed Descriptions

G031D540.WMF

## 2.8.2 DEVICES

The engine control board controls the printer engine system.

Devices	Functions
CPU	16-bit microprocessor Internal RAM: 512 bits
Gate Array (GAZELLE)	Serial communication control for I/F controller Laser printing control Power width modulation (PWM) timer. LD driver sample hold function Pattern generation Fusing unit control timer I/O port
EPROM	128 K engine firmware ROM
EEPROM	Service maintenance information (counters, registration, etc.) 1 kbit
SRAM	32 KB
TB1	The test pattern will be printed when TB1 is shorted.



**2.8.4 CONNECTION TO THE ECB**

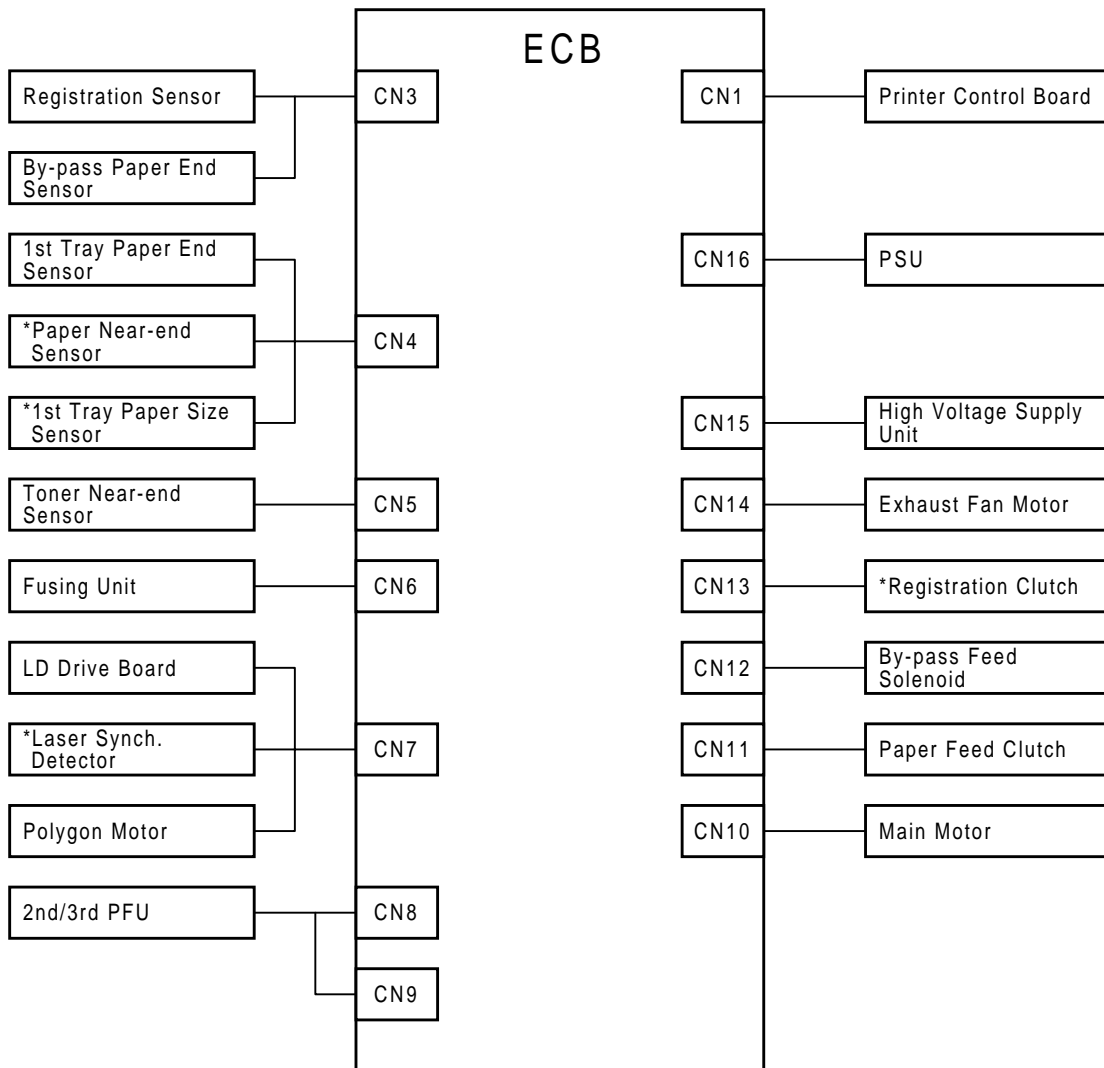

G031D542.WMF

\* The Stinger - P4 does not use the following:

- 1) 1st paper size sensor
- 2) Paper near end sensor
- 3) Laser synchronization detector board (It is on the LD drive board.)
- 4) Registration clutch

CN	Description
CN1	Supplies +5 V to the printer control board. Also passes the video, engine control, and the serial data signals
CN3	Signals from the registration sensor and by-pass paper end sensor
CN4	Signals from the 1 <sup>st</sup> tray paper size and paper end sensors. For the Stinger – P3, also from the 1 <sup>st</sup> tray paper near-end sensor
CN5	Signal from the toner near-end sensor
CN6	Signals from the fusing unit thermistor (hot roller temperature) and the fusing exit sensor Determines whether a 120 V or 200 V fusing unit is installed
CN7	Automatic laser power control signal, video signal Polygon motor on/off and rotation speed control Detects the polygon motor lock condition. Signal from the laser synchronization detector (The detector is built into the LD drive board in the Stinger - P4.)
CN8/9	Signals from the sensors in the optional paper feed units. Control for the clutches and motors
CN10	Main motor on/off control, and main motor lock detection
CN11	Turns the 1st tray paper feed clutch/solenoid on/off
CN12	Turns the by-pass tray solenoid on/off
CN13	Turns the registration clutch on/off (only used for Stinger - P3)
CN14	Turns the fan motor on/off and controls the fan motor speed.
CN15	Controls the charge voltage, development bias, and transfer roller bias.
CN16	+5 V and +24 V from the PSU. The interlock switch cuts the +24 V when the front cover is opened. Controls the fusing unit safety relay Turns the power to the fusing unit on/off.

Detailed  
Descriptions

## 2.9 SIGNAL TABLE

CN	Signal	I/O	Description
CN1-A1	GND		
CN1-A2	GND		
CN1-A3	+5V		
CN1-A4	N.C		
CN1-A5	FGATE	O	Sub scan data printing area signal
CN1-A6	PPRDY	O	Printing ready
CN1-A7	/RDY	O	Printing enable
CN1-A8	/SBSY	O	Enables communication with the controller
CN1-A9	/SCLK	O	Synchronization clock for serial communication with the controller
CN1-A10	/STS	O	Serial status to the controller
CN1-B1	/VIDEO	I	Video data
CN1-B2	GND		
CN1-B3	+5V		
CN1-B4	+5V		
CN1-B5	/BD	O	Main scan synchronization signal.
CN1-B6	CPRDY	I	Controller power ready
CN1-B7	/PRINT	I	Printing request
CN1-B8	/CBSY	I	Enables communication from the controller
CN1-B9	/CCLK	I	Synchronization clock for serial communication from the controller
CN1-B10	/CMD	I	Serial command from the controller
CN2-1	+5V		
CN2-2	/RXD	I	Designer use only
CN2-3	/TXD	O	Designer use only
CN2-4	GND		
CN3-1	GND		
CN3-2	/REGST	I	Registration sensor signal
CN3-3	+5V		
CN3-4	GND		
CN3-5	MPEND	I	By-pass tray paper end signal
CN3-6	+5V		
CN4-1	GND		
CN4-2	FPEND	I	1st tray paper end signal
CN4-3	GND		
CN4-4	/FPNE	I	1st tray paper near-end signal
CN4-5	FPS0	I	1st tray paper size signal
CN4-6	FPS1	I	1st tray paper size signal
CN4-7	GND		
CN4-8	FPS2	I	1st tray paper size signal
CN5-1	GND		
CN5-2	/TEND	I	Toner near-end condition
CN5-3	N.C		
CN5-4	+5V		
CN6-1	GND		
CN6-2	/FSET0	I	Fusing unit 100V/200V selection

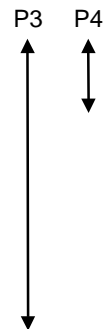

CN	Signal	I/O	Description
CN6-3	/FSET1	I	Fusing unit 100V/200V selection
CN6-4	/FSET2	I	Fusing unit 100V/200V selection
CN6-5	+5V		
CN6-6	FTEMP	I	Fusing unit temperature detection (analog)
CN6-7	GND		
CN6-8	/EXIT	I	Fusing exit sensor
CN6-9	+5V		
CN7-1	+24V	I	
CN7-2	GND		
CN7-3	XSMSTA	O	Polygon motor on signal
CN7-4	/SMLOK	I	Polygon motor lock signal
CN7-5	SMCK	O	Polygon motor clock signal
CN7-6	CHLDP	O	LD power signal (L: 600, H: 1200)
CN7-7	+5VS		
CN7-8	APCSH	O	LD drive signal
CN7-9	GND		
CN7-10	/VD	O	LD on signal
CN7-11	GND		
CN7-12	/LD EN	O	LD drive enable signal
CN7-13	/DETP	I	Main scan synchronization signal
CN7-14	+5V		
CN7-15	GND		
CN8-1	+24V		
CN8-2	GND		
CN8-3	GND		
CN8-4	+5V		
CN8-5	SNDCK	O	2nd PFU motor lock
CN8-6	XSNDFD	O	2nd PFU motor on
CN8-7	XSNDCL	O	2nd PFU paper end clutch on
CN8-8	SPSEN	I	2nd PFU paper feed sensor
CN8-9	EPEND	I	2nd PFU paper end detection
CN8-10	/OTSET	I	2nd PFU paper detection
CN9-1	CHG2	O	2nd/3rd PFU sensor select
CN9-2	OPS0	I	PFU paper size sensor signal
CN9-3	OPS1	I	PFU paper size sensor signal
CN9-4	OPS2	I	PFU paper size sensor signal
CN9-5	TRDCK	O	3rd PFU paper feed motor lock
CN9-6	/TRDFD	O	3rd PFU motor on
CN9-7	/TRDCL	O	3rd PFU paper feed clutch on
CN9-8	TPSEN	I	3rd PFU paper feed sensor
	/FCSET	I	No cassette signal for 1st tray (P4)
CN9-9	OPNE0	I	PFU paper near end condition
CN9-10	OPNE1	I	PFU paper near end condition
CN9-11	OPS0	I	PFU paper size detection
CN9-12	OPS1	I	PFU paper size detection
CN9-13	OPS2	I	PFU paper size detection
CN9-14	OPEND	I	PFU paper end detection
CN9-15	XOTSET	I	PFU paper detection

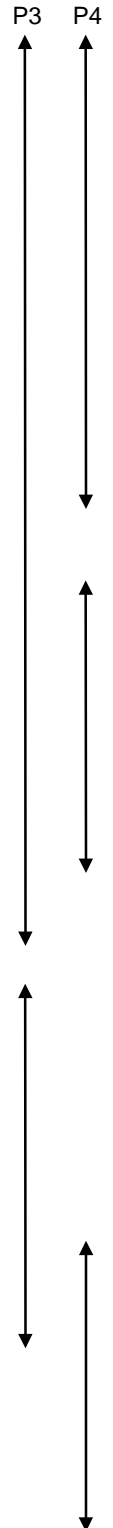

Detailed Descriptions

CN	Signal	I/O	Description
CN10-1	CHMMS	I	Main motor speed signal (H: 600, L: 1,200)
CN10-2	HMLOK	I	
CN10-3	/MMTR	O	
CN10-4	GND		
CN10-5	GND		
CN10-6	+24V		
CN10-7	+24V		
CN11-1	+24V		1st tray paper feed clutch enable
CN11-2	/FSTCL	O	
CN12-1	+24V		By-pass tray paper feed solenoid enable
CN12-2	/MLTSOL	O	
CN13-1	+24V		Registration clutch enable
CN13-2	/REGCL	O	
CN14-1	+24V		Fan motor enable
CN14-2	/FAN	O	
CN15-1	N.C		Transfer roller bias feedback signal
CN15-2	N.C		
CN15-3	CVFB	I	
CN15-4	TCCFB	I	
CN15-5	MCVFB	I	
CN15-6	BIUFB	I	
CN15-7	/MCAC	O	
CN15-8	/BIAC	O	
CN15-9	TCPWM-	O	
CN15-10	TCPWM+	O	
CN15-11	MCPWM	O	
CN15-12	BIPWM	O	
CN15-13	GND		
CN15-14	+24V		
CN16-1	+24V		Fusing relay enable
CN16-2	GND		
CN16-3	+5V		
CN16-4	GND		
CN16-5	/FURLY	O	
CN16-6	/HEAT	O	
CN17-1	+24V		Fusing relay on (Factory use)
CN17-2	/FULRY		

P3





## 2.10 PRINTER CONTROL BOARD

### 2.10.1 PCB LAYOUT

#### Stinger - P3

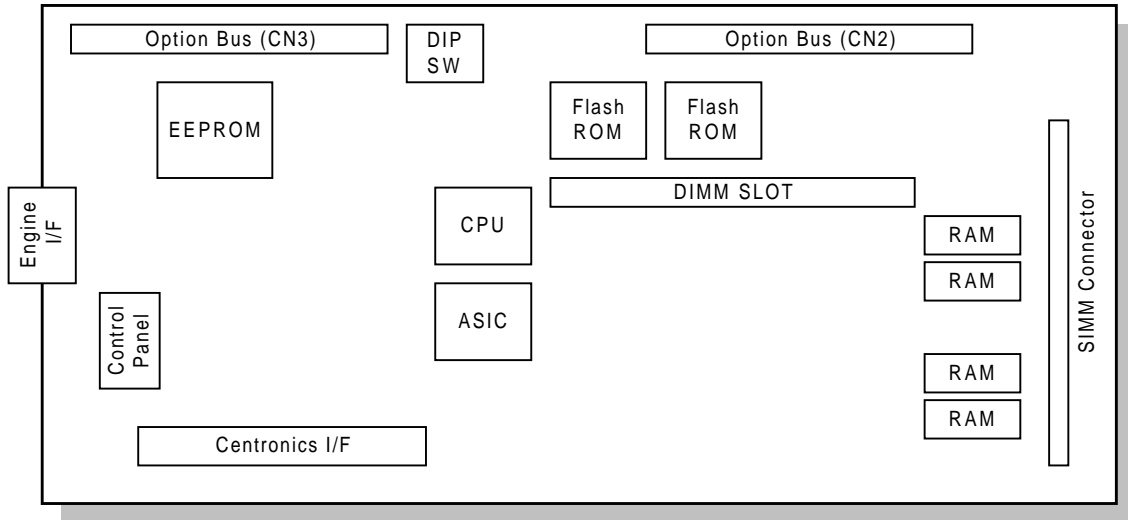

Detailed Descriptions

G031D538.WMF

#### Stinger - P4

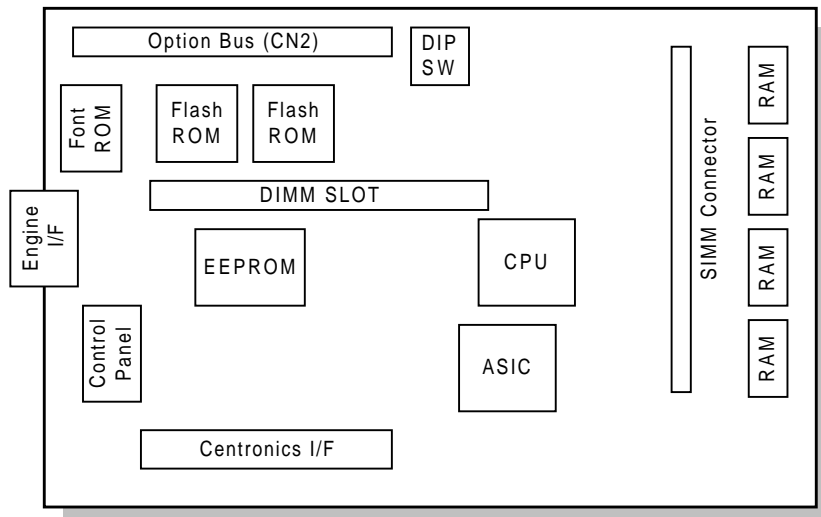

G031D539.WMF

**2.10.2 DEVICES**

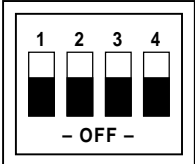
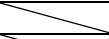
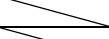
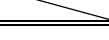
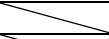
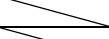
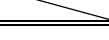
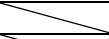
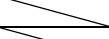
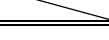
Devices	Description																	
CPU	133MHz VR4310																	
ASIC: ROCKY W	Memory map control																	
	Reset signal																	
	DRAM control																	
	DMA control																	
	FCI control (edge smoothing, toner saving)																	
	Interrupt control																	
	Engine serial communication control																	
	Interval control																	
	Centronics I/F																	
	I/O port																	
Code ROM	Flash ROM (8 MB) 32 bit																	
DRAM	8 MB (16 Mbit DRAM x 4)																	
EEPROM	2 KB (NVRAM)																	
Centronics I/F	Bi-directional parallel interface (standardized by IEEE1284)																	
OPTION I/F	P3: 2 slots RS232C Ethernet (100 Base-Tx, 10 Base-T) Hard disk drive IC Card adapter for up-dating controller firmware (CN3)																	
	P4: 1 slot Ethernet (100 Base-Tx, 10 Base-T) Hard disk drive IC Card adapter for up-dating controller firmware																	
Optional RAM I/F	SIMM x 1 slot, 16 MB or 32 MB SIMM																	
DIMM I/F	1 slot																	
DIP SW	<div style="text-align: center;">  </div> <p style="text-align: right;">G031D537.WMF</p> <table border="1" style="margin-left: auto; margin-right: auto;"> <thead> <tr> <th>SW No.</th> <th>Setting</th> <th>Description</th> </tr> </thead> <tbody> <tr> <td rowspan="2" style="text-align: center;">1</td> <td style="text-align: center;">OFF</td> <td>Booting from Flash ROM</td> </tr> <tr> <td style="text-align: center;">ON</td> <td>Booting from IC card</td> </tr> <tr> <td style="text-align: center;">2</td> <td style="text-align: center;"></td> <td>Not used</td> </tr> <tr> <td style="text-align: center;">3</td> <td style="text-align: center;"></td> <td>Not used</td> </tr> <tr> <td style="text-align: center;">4</td> <td style="text-align: center;"></td> <td>Not used</td> </tr> </tbody> </table>	SW No.	Setting	Description	1	OFF	Booting from Flash ROM	ON	Booting from IC card	2		Not used	3		Not used	4		Not used
SW No.	Setting	Description																
1	OFF	Booting from Flash ROM																
	ON	Booting from IC card																
2		Not used																
3		Not used																
4		Not used																

## 3. INSTALLATION

### 3.1 INSTALLATION REQUIREMENTS

#### 3.1.1 ENVIRONMENT

1. Temperature Range: 10°C to 32°C (50°F to 89.6°F)
2. Humidity Range: 15% to 80% RH
3. Ambient Illumination: Less than 1,500 lux (do not expose to direct sunlight.)
4. Ventilation: Room air should turn over at least 3 times/hr/person
5. Ambient Dust: Less than 0.10 mg /m<sup>3</sup> (2.7 x 10<sup>-6</sup> oz/yd<sup>3</sup>)
6. Avoid areas which are exposed to sudden temperature changes. This includes:
  - 1) Areas directly exposed to cool air from an air conditioner.
  - 2) Areas directly exposed to heat from a heater.
7. Do not place the machine in an area where it will be exposed to corrosive gases.
8. Do not install the machine at any location over 2,000 m (6,500 ft.) above sea level.
9. Place the machine on a strong and level base. (Inclination on any side should be no more 5 mm.)
10. Do not place the machine where it may be subjected to strong vibrations.

#### 3.1.2 POWER REQUIREMENTS

##### CAUTION

1. **Make sure that the wall outlet is near the machine and easily accessible.**
2. **Make sure the plug is firmly inserted in the outlet.**
3. **Avoid multi-wiring.**
4. **Be sure to ground the machine.**

1. Input voltage level: Stinger - P3
  - 120 V, 60 Hz: More than 8.0 A (for North America)
  - 220 V ~ 240 V, 50/60 Hz: More than 8.0 A (for Europe)
 Stinger - P4
  - 120 V, 60 Hz: More than 6.0 A (for North America)
  - 220 V ~ 240 V, 50/60 Hz: More than 5.0 A (for Europe)
2. Permissible voltage fluctuation : 5%
3. Do not set anything on the power cord.

### **3.2 PRINTER INSTALLATION**

See the “Quick Installation Guide” sheet that comes with the printer.

### **3.3 PAPER FEED UNIT INSTALLATION**

See the “Installing the Paper Feed Unit” section in the Operating Instructions.

### **3.4 ENVELOPE FEEDER INSTALLATION**

See the “Installing the Envelope Feeder” section in the Operating Instructions.

### **3.5 HARD DISK INSTALLATION**

See the “Hard Disk Installation” sheet that comes with the option.

### **3.6 MEMORY UNIT INSTALLATION**

See the “Installing the Memory Unit” section in the Operating Instructions.

### **3.7 NETWORK INTERFACE BOARD INSTALLATION**

See the “Installing the Network Interface Board” section in the Operating Instructions.

## 3.8 CHECKING THE CONNECTIONS

### 3.8.1 CONNECTION BETWEEN MAIN PRINTER CONTROL BOARD (AND RELATED OPTIONS: HDD, RAM SIMM, NIC) AND OPTIONAL HDD & PERIPHERALS

G031/032-17

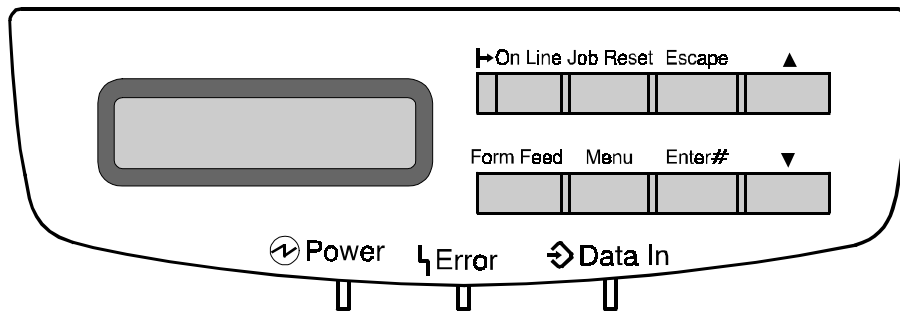

G031I501.WMF

G031/032-22, -27, -29

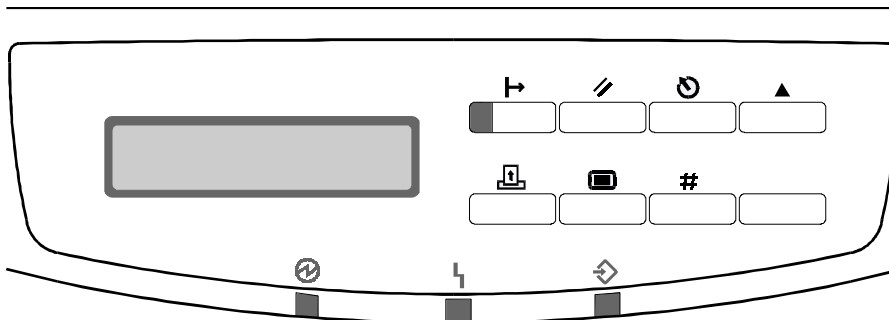

G031I502.WMF

Please refer to the key names and locations in the above illustration.

1. Plug in the power cord and turn on the main switch. Then "Ready" is displayed.
2. Press the "Menu" key to enter the Main Menu.
3. Press the "Arrow" key to select List Print.
4. Press the "Enter" key to enter the List Print menu.
5. Press the "Enter" key twice to print the System Config. page.

**NOTE:** For more detailed information about the machine operation panel settings, refer to the Operating Instructions.

An example of the configuration page follows.

<b>Model Name</b>		<b>Configuration Page</b>	
<b>Reference</b>		<b>Host Interface</b>	
Firmware Version	2.23.22	Print Language	Auto
Engine Version	1.1	Network Setup	
Pages Printed	123456	IP Address	133.139.211.6
Maintenance Counter	43456	Subnet Mask	255.255.255.0
Total Installed RAM	36 MB	Gateway Address	133.139.211.1
Hard Disk	815 MB	RS232C Setup	
Network Card	Ethernet	Baud Rate	9,600
DIMM Card	Attached	Parity	None
		Flow Control	Xon/Xoff
		Data Bits	8
		Stop Bits	1
		DTR Polarity	High
<b>Paper Input</b>			
Tray Priority	Tray 1		
Tray Locking	None		
Tray Size			
By-pass Tray	Letter 8 1/2 x 11		
Tray 1	Letter 8 1/2 x 11		
Tray 2	Letter 8 1/2 x 11		
Tray 3	Letter 8 1/2 x 11		
Thick Paper	Off		
<b>Print Quality</b>		<b>PostScript</b>	
Edge Smoothing	Off	PostScript Version	72.103
Resolution	1,200 dpi	Print PS Errors	off
Image Density	Normal		
Toner Saving	On		
<b>System</b>		<b>Ethernet</b>	
Copies	1	Software Version	5.01
Jam Recovery	On	Hardware Address	00:00:C9:00:00:07:82
I/O Timeout	30 seconds	Novell (IPX/SPX)	
Energy Saver	30 minutes	Pserver Name	RDP-000123
Auto Continue	Off	Frame Type	802.2
Page Protect	On	TCP/IP	
		IP Address	133.139.211.6
		Gateway	133.139.211.1
		Subnet Mask	255.255.255.0
<b>PCL Menu</b>			
Orientation	Portrait		
Form Length	60		
Font Source	Internal		
Font Number	0		
Font Height	12.00		
Font Pitch	10.00		
Symbol Set	Roman 8		

## Model Name

### Reference

Firmware Version	2.23.22	—— [A]
Engine Version	1.1	—— [B]
Pages Printed	123456	
Maintenance Counter	43456	—— [C]
Total Installed RAM	36 MB	—— [D]
Hard Disk	815 MB	—— [E]
Network Card	Ethernet	—— [F]
DIMM Card	Attached	—— [G]

G031I500.WMF

The maintenance counter [C] shows the main motor work time counter (the unit is 5000 seconds).

Check the following:

- For the main printer control board, check that the machine prints the configuration page fully.
- For the RAM SIMM, confirm that “Total Installed RAM” [D] on the printout shows the size of the module just installed, plus 8 Mbytes (the base memory on the board).
- For the hard disk, confirm that “Hard Disk” [E] printed on the configuration page shows the size of the hard disk.
- For the NIB, confirm that “Network Card” [F] printed on the configuration page shows the type of network card.
- For the PCL version of the printer control board, check “Firmware Version” [A].
- For the software version of the engine control board, check “Engine Version” [B].

If there are any problems with the above check items, reinstall the printer controller and other options. Then set up the machine again and test it again.

### 3.8.2 CONNECTION BETWEEN PRINTER CONTROL BOARD AND NETWORK INTERFACE BOARD

There are three ways to check the connection between the main printer control board and the network interface board.

- Check that the configuration page includes Ethernet settings.
- Check the “NIB Setup” menu in the Host Interface menu on the machine’s operation panel.
- Print out the Network Interface Board Configuration Sheet with the network information (see below).

### 3.8.3 PRINTING THE NETWORK INTERFACE BOARD CONFIGURATION SHEET

**NOTE:** The NIB configuration sheet will be printed out once just after turning on for the first time when the NIB is installed.

1. Install the network interface board.
2. Turn on the main switch and wait for a few minutes.
3. The configuration sheet will be printed automatically.

**NOTE:** If the printer does not print the network interface board configuration sheet, check the NIB setup menu in the Host Interface menu (user program mode). If this menu is not displayed, the NIB is not connected properly.

If any problem occurs during the above steps, reinstall the NIB and other options, then set the machine up again and test it again.



## 4. SERVICE PROCEDURES AND TABLES

### 4.1 OVERVIEW

There are three service menus with this machine.

- Service Program Mode: This contains most of the field procedures, and is covered in section 4.2
- IC Card Boot Service Mode: Most of these features are covered in the Appendix, which describes procedures that are mainly for use in the service station.
- Service Tool Menu: This is also covered in the Appendix.

#### *Operation panel*

Please refer to the illustration for the key names and their locations.

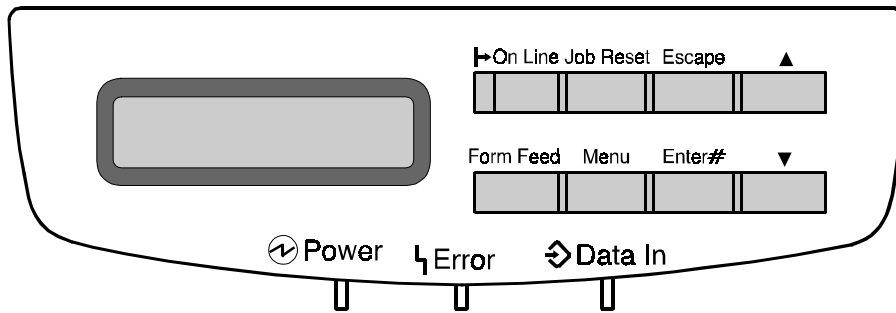

G031M501.WMF

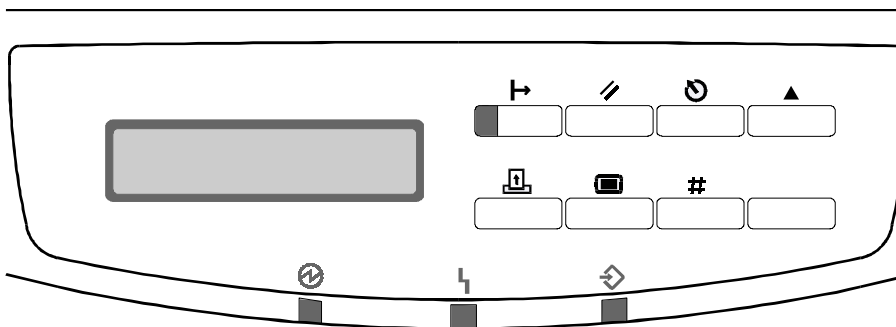

G031M506.WMF

Service  
Tables

## 4.2 SERVICE PROGRAM MODE

### CAUTION

Before accessing the service menu, do the following:

Confirm that there is no print data in the printer buffer (the Data In LED must not be lit or blinking).

If there is some data in the buffer, wait until all data has been printed.

### 4.2.1 ENABLING AND DISABLING SERVICE PROGRAM MODE

#### *Enabling the Service Mode*

1. Turn the machine on while pressing the "On Line" key and "Escape" key together until the service mode menu appears on the display.
2. When the machine goes into the service mode, all LEDs are lit.
3. Use the "arrow" keys to scroll through the menu listing. To select an item, press the "Enter" key. Then the sub-menu will appear.
4. To return to the 1st level menu, press the "Escape" key several times.

**NOTE:** If the "On Line" key and "Escape" key are not pressed together while turning on, the service mode menu will not be available.

#### *Disabling the Service Mode*

There are two ways to exit the service mode.

1. Turning off and on
  - 1) Turn off the machine.
  - 2) Wait for a few seconds and then turn it on again. The user mode menu will appear.
2. "Form Feed" key and "Escape" key
  - 1) Press the "Form Feed" key and "Escape" key together.
  - 2) Wait a few seconds. The machine exits service mode automatically.
  - 3) The printer starts to initialize.

### 4.2.2 SERVICE PROGRAM MODE MENU TREE

The following diagram shows the service mode menu tree.

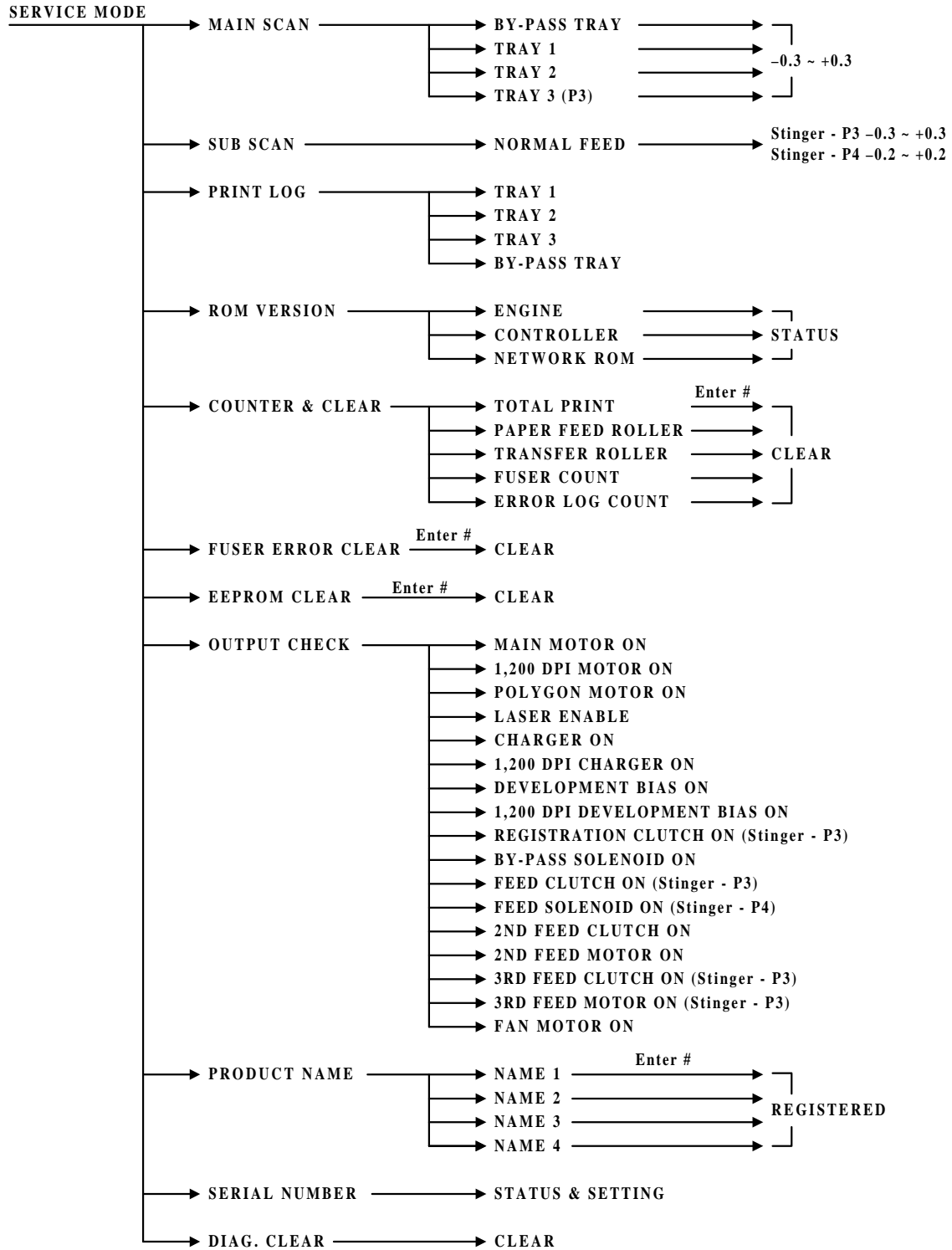

Service Tables

*Service Mode Submenu*

***Accessing the Required Program***

Select each program level in sequence.

1. Scroll through the 1st level programs using the “Up/Down arrow” keys. Then press the “Enter” key.
2. Scroll through the items in the next lowest level using the “Up/Down arrow” keys. To go back to a higher level, press the “Escape” key.

***Inputting a Value or Setting for a Service Program***

1. Enter the required program mode as explained above.  
**NOTE:** The setting appearing initially on the display is the current setting.
2. Select the required setting using the “Up/Down arrow” keys, then press the “Enter” key.  
**NOTE:** The previous value remains if the “Enter” key is not pressed.
3. Exit service mode.

### 4.2.3 SERVICE MODE MENU TABLE

In the Function column, comments are in italics.

Menu Level			Function	Settings
Level 1	Level 2			
Main Scan	Tray 1	Side-to-side Registration (Feed from Paper Tray 1)	Adjusts the printing side-to-side registration from paper tray 1 using the frame on the Print Log.	-0.3 ~ +0.3 mm 0.1 mm/step
			<i>Use the "▲/▼" keys to increase or decrease. See "Replacement and Adjustment - Print Registration Adjustments" for details.</i>	
	Tray 2	Side-to-Side Registration (Feed from Tray 2 - Optional Paper Feed Unit)	Adjusts the printing side-to-side registration from paper tray 2 using the frame on the Print Log.	-0.3 ~ +0.3 mm 0.1 mm/step
			<i>Use the "▲/▼" keys to increase or decrease. See "Replacement and Adjustment - Print Registration Adjustments" for details.</i>	
Tray 3 (Stinger - P3)	Side-to-side Registration (Feed from Paper Tray 3 - Optional Paper Feed Unit)	Adjusts the printing side-to-side registration from paper tray 3 using the frame on the Print Log.	-0.3 ~ +0.3 mm 0.1 mm/step	
		<i>Use the "▲/▼" keys to increase or decrease. See "Replacement and Adjustment - Print Registration Adjustments" for details.</i>		
By-pass Tray	Side-to-Side Registration (Feed from Bypass Tray)	Adjusts the printing side-to-side registration from the bypass tray using the frame on the Print Log.	-0.3 ~ +0.3 mm 0.1 mm/step	
		<i>Use the "▲/▼" keys to increase or decrease. See "Replacement and Adjustment - Print Registration Adjustments" for details.</i>		
Sub Scan	Normal Feed	Leading Edge Registration (Normal Printing)	Adjusts the printing leading edge registration using the frame on the Print Log.	-0.3 ~ +0.3 mm for Stinger - P3 -0.2 ~ +0.2 mm for Stinger - P4 0.1 mm/step
			<i>Use the "▲/▼" keys to increase or decrease. See "Replacement and Adjustment - Print Registration Adjustments" for details.</i>	
Counter Clear	Total Print	Total Print & Counter Reset	Views and resets the total print counter.	
			<i>To view the counter, press the "Enter" key then press the "Escape" key.</i>	
			<i>To reset the counter, press the "Enter" key again after the counter is displayed.</i>	

Service  
Tables

Menu Level			Function	Settings	
Level 1	Level 2				
Counter Clear	Paper Feed	Paper Feed Roller Counter & Reset	Views and resets the paper feed counter.		
			<i>To view the counter, press the "Enter" key then press the "Escape" key.</i>		
			<i>To reset the counter, press the "Enter" key again after the counter is displayed.</i>		
	Transfer Roller	Transfer Roller Counter & Reset	Views and resets the transfer roller counter.		
			<i>To view the counter, press the "Enter" key then press the "Escape" key.</i>		
			<i>To reset the counter, press the "Enter" key again after the counter is displayed.</i>		
	Fusing	Fusing Counter & Reset	Views and resets the fusing counter.		
			<i>To view the counter, press the "Enter" key then press the "Escape" key.</i>		
			<i>To reset the counter, press the "Enter" key again after the counter is displayed.</i>		
	Error Log & Counter	Error Log/ Counter & Reset	Views and resets the error log list and the error log counters.		Up to ten errors are registered. These are the same as the 'Error Logging' entries on the Print Log.
			<i>To view the log and counters, press the "Enter" key then press the "Escape" key.</i>		
			<i>To clear the log and counters, press the "Enter" key again after it is displayed.</i>		
EEPROM Clear		Memory All Clear on Engine Control Board	Resets all software counters. Also, resets all adjustment settings and log entries. <b>Normally, this service mode should not be used.</b>		
Fusing Error Clear		Clear the Fuser Error	Resets a fusing unit error.		
Print Log			Prints the print log <i>To print the log sheet, select the tray using the "▲/▼" keys then press the "Enter" key. See the "Print Log" section for details.</i>		
ROM Version	Engine	ROM Version Display (ECB)	Displays the Engine Control Board ROM version.		
	Controller	F/W Version Display (Main Control Board)	Displays the main printer control board firmware version.		
	Network ROM	NIB Firmware version Display	Displays the NIB firmware version.		

Menu Level			Function	Settings
Level 1	Level 2			
Output Check	Main Motor		<p>To check the outputs, press the "Enter" key. Press the "Enter" key again to stop the check. The menu will go back to level 2 when the "Escape" key is pressed.</p> <p><b>Note:</b>                      1. OK/NG are not displayed.                      2. To prevent mechanical or electrical damage, do not keep an electrical component on for a long time.</p> <p>Charger: Charge roller</p>	
	1,200 dpi Motor			
	Polygon Motor			
	Laser Enable			
	Charger ON			
	1,200 dpi Charger ON			
	Development Bias ON			
	1,200 dpi Development Bias ON			
	Registration Clutch ON (Stinger - P3)			
	By-pass Solenoid ON			
	Feed Clutch ON (Stinger - P3)			
	Feed Solenoid ON (Stinger - P4)			
	2nd Feed Clutch ON			
	2nd Feed Motor ON			
	3rd Feed Clutch ON (Stinger - P3)			
3rd Feed Motor ON (Stinger - P3)				
Fan Motor				
Product Name		Plug and Play Model Name	<p>Select the product name</p> <p><i>Use the "▲/▼" keys to select the name. This name is used for the plug and play name and is indicated on the top of configuration page and print log.</i></p>	
	<p><b>Note:</b></p> <ol style="list-style-type: none"> <li>The product name is stored in the NVRAM on the controller board.</li> <li>Macintosh printers use the product name as a printer name.</li> <li>When the IC Card boot menu NVRAM clear is done, store the product name again.</li> <li>User settings stored in the NVRAM are reset when the product name is changed.</li> </ol>			

Service Tables

Menu Level			Function	Settings
Level 1	Level 2			
Serial Number		Printer ID Setting	Views and stores the printer ID <i>To view the printer ID, press the "Enter" key.</i> <b>Normally, the printer ID should not be changed.</b>	
		<b>Note:</b> 1. The serial number is stored in the NVRAM on the controller board. 2. The printer ID is checked during font downloading. 3. Store the same number when the NVRAM is cleared with the IC card boot menu. 4. The product number of the controller board is used as the printer ID and stored in the factory.  See the "Printer ID" section how to store the serial number.		
Diag. Clear		Diagnostic Error Log Clear	Clear the diagnostic error log. <i>To clear the log, press the "Enter" key.</i>	



### 4.2.4 PRINT LOG

#### Sample

An example of the print log follows.

```

PRINT LOG          98877669-MODEL NAME — [A]

ROM version
Engine ROM version      : V1.10 — [B]
Controller ROM version  : V1.00 — [C]
Network ROM version     : V5.32 — [D]

Register Setting
Sub Scan (-3.0 mm to +3.0 mm)
Normal Feed             : -0.5 — [E]
Main Scan (-3.0 mm to +3.0 mm)
By-pass Tray           : +0.5
Tray 1                  : +1.0      A4   [2/2]
Tray 2                  : +1.0      DLTR [1/4]
Tray 3                  : +1.0      FREE [2/4] — [F]

Transition             : Normal — [G]
Density                : Light 2
Total Print Count      : 1          [Unit: 1 page]
Motor Work Time        : 0          [Unit: 5000 sec]
Paper Feed Roller Counter : 0      [Unit: 5000 sec] — [H]
Transfer Roller Counter : 0      [Unit: 5000 sec]
Fuser Counter          : 0          [Unit: 5000 sec]

Error Logging
1. Paper Feed Jam      : 00000010 [Unit: 200 pages] — [I]
2.                    :
3.                    :
4.                    :
5.                    :
6.                    :
7.                    :
8.                    :
9.                    :
10.                   :

Diagnostic Error Logging
1. OPTION DIMM         : 0 X 1010 — [J]
2. OPTION NIC          : 0 X 1301
3. ASIC P1284         : 0 X 0902
4. OPTION NIC          : 0 X 1301
5. ASIC P1284         : 0 X 0902
6. ASIC P1284         : 0 X 0902
7.                    :
8.                    :
9.                    :
10.                   :
[K]
    
```



### ***Printing the Log Sheet***

To print the log sheet, do the following.

1. Turn on the machine while pressing the “On Line” key and “Escape” key together to enter the service mode.  
**NOTE:** For the key locations, see “Enabling and Disabling Service Program Mode”.
2. Use the “arrow” keys until “PRINT LOG” appears. Then press the “Enter” key.
3. Use the “arrow” keys to select the appropriate tray then press the “Enter” key.

### ***Items on the Log Sheet***

#### **[A]: Serial Number and Model Name (Printer ID)**

The serial number and model name are stored in the NVRAM on the printer control board. The Printer ID consists of the serial number and the model name together.

#### ***- Serial Number -***

The 8-digit serial number is stored in the factory. Each printer control board has a serial number and it is printed on the PCB.

Normally, when the printer control board is changed, the NVRAM on the board is removed and then installed on the new board. In this case, do not change the serial number (the machine’s Printer ID must never be changed, regardless of the printer control board serial number). After clearing the NVRAM or replacing the NVRAM, the original number must be stored again, using ‘Serial Number’ in service program mode.

See the “Printer ID” section for the purpose of the printer ID and how to store it.

#### ***- Model Name -***

The model name is the same as the product name input with service program mode. The model name is stored in the factory and is used for the “plug and play” name. Normally, the product name does not have to be changed in the field. After clearing the NVRAM or replacing the NVRAM, restore the model name using ‘Product Name’ in service program mode.

**NOTE:** When the model name is restored by service program mode in the field, the NVRAM will be partially cleared (user settings such as print quality settings and system settings on the configuration sheet are reset).

If the NVRAM was cleared and the product name was lost, when the log sheet is printed, “?????” is marked on the log print.

Refer to the “IC Card Boot Service Menu” section for how to reset the NVRAM.

#### **[B]: Engine ROM version**

The engine control board firmware version. This firmware can only be updated by replacing the EPROM on the engine control board.

**[C]: Controller ROM version**

The printer control board firmware version. The controller firmware consists of PCL firmware, PostScript firmware and diagnostic firmware. The controller ROM version changes when one or more of these is updated.

The controller firmware version is stored in the NVRAM on the printer control board. Only the controller firmware can be installed by the IC card, DIMM card and downloading from PC. The engine firmware and NIB firmware cannot be installed using these methods.

**[D]: Network ROM version**

The NIB firmware version. The firmware can be updated with utility software on a PC connected to the NIB through the network.

**[E]: Sub Scan/Main Scan**

Registration has been adjusted in the factory. The settings are stored in the EEPROM on the ECB. When the EEPROM is cleared with service program mode or is replaced in the field, the settings go to the defaults. Before clearing or replacing the EEPROM, note the current values, then re-input them afterwards.

**[F]: Tray paper status**

This shows the paper size and amount of paper remaining. The remaining paper is showed in 2 steps (for the 1<sup>st</sup> tray) or 4 steps (for the 2<sup>nd</sup> and 3<sup>rd</sup> trays). "0/4" means no paper and "4/4" means the tray is full.

**[G]: Transition/Density**

This shows the transfer current and image density settings in the engine board. These are user settings, and they go to normal when the EEPROM is cleared.

**[H]: Counters**

These counters can be reset using counter clear in the service program mode menu, except for the motor work time. All counters are cleared when the EEPROM is cleared.

The motor work time, paper feed roller counter, transfer roller counter, and fusing unit counter are counted by the main motor rotation. The counters go up by one every 5,000 seconds of motor working time.

These counters (except the motor work time) can be checked on the display using the service program mode. To see the motor work time, look at "Maintenance Counter" on the configuration page.

The paper feed roller counter, transfer roller counter and fuser counter are automatically reset when new fusing unit in the Maintenance KIT is installed (Stinger - P3).

When the PM clear is performed by user menu, these counters are reset.

**[I]: Error Logging**

The ten latest engine errors are logged. The counters go up every 200 prints. For example, if the counter shows 10, the error occurred somewhere between print numbers 2,000 and 2,199.

The errors included here are:

- Paper Feed Jam
- Transport Jam
- Paper Exit Jam
- Fuser Reload Error (could not return to the 'ready to print' temperature)
- Fuser Heater High Error
- Fuser Heater Low Error
- Synchronizing Pulse Error (for the laser)
- Polygon Motor Error
- Main Motor Error
- High Voltage Error (high voltage power supply)

The log is stored in the EEPROM and can be cleared using counter clear in the service program mode menu.

**[J]: Diagnostic Error Logging**

The ten latest errors are logged. The log is stored in the NVRAM and can be cleared by 'Diag clear' in the service program mode menu. When the printer control board is replaced and the old NVRAM is installed on the new board, the diagnostic errors should be cleared because these errors occurred with the old printer control board.

e.g. 0 x 1010

└── Error code (see section 7 for details of the codes).

└── Means that the following is a hex number.

**[K]: Print Log Frame**

This frame is drawn a sixth of an inch (4.2 mm) from the paper edges. The registration is adjusted in the factory. If the registration has drifted, adjust the sub scan or the main scan (see "Replacement and Adjustment - Print Registration Adjustment").

### 4.2.5 PRINTER ID

#### Overview

The user can buy fonts and install them in the printer hard disk. The font software uses the printer ID to prevent the fonts from being downloaded to several printers illegally. The fonts must be downloaded to one printer only.

The original printer ID is stored in the NVRAM on the printer control board in the factory. The serial number of the printer control board is used for the ID. When the printer control board is replaced in the field, the old NVRAM is installed on the new board. In this case, the printer ID does not need to be restored.

When the NVRAM is cleared or changed because of a hardware problem, the original printer ID must be restored.

#### Restoring the Printer ID

The printer ID can be stored using the service program mode as follows.

1. Turn on the printer while pressing the "Online" key and "Escape" key together to enter the service menu.

**NOTE:** For the key locations, see "Enabling and Disabling Service Program Mode".

Service Mode: 1. Main Scan
-------------------------------

G031M528.WMF

Use the "arrow" key.

Service Mode: 10. Serial Number
------------------------------------

G031M510.WMF

Press the "Enter" key.

Serial Number: 80900082
----------------------------

G031M511.WMF

An 8-digit numeral appears.

2. Press the "Online" key, "Form feed", "Menu" key, and "Up arrow" key at the same time

A cursor will appear under the 1st digit.

Serial Number: <u>8</u> 0900082
------------------------------------

G031M512.WMF



- 3. Use the "arrow" key to change the number and press the "Enter" key to store the displayed number.

**NOTE:** Store the same number which had been stored previously (see the top of the Print Log sheet).

The printer control board has a serial number printed on the board, but if the old board had been replaced earlier, the serial number on the new board must not be used for the Printer ID.

Serial Number:  
10000000

G031M513.WMF

- 4. Then the cursor shifts to the right.

Serial Number:  
12345678

G031M514.WMF

- 5. To store the number in the display, press the "Enter" key.

Service Mode:  
10. Serial Number

G031M510.WMF

- 6. The display goes back to the top menu.

- 7. Use the "arrow" keys to select "PRINT LOG".

Service Mode:  
3. PRINT LOG

G031M515.WMF

- 8. Print the log sheet and check that the printer ID at the top of the page (serial number and model name) is correct.

## 4.3 IC CARD BOOT SERVICE MODE

### 4.3.1 OVERVIEW

The IC card booting service menu is accessed only by booting from an IC card. The IC card is prepared as a service tool.

**NOTE:** A blank IC card cannot be used to boot up the printer.

### 4.3.2 ENABLING AND DISABLING IC CARD BOOT SERVICE MODE

#### *To enter the service mode*

1. Turn the printer off.
2. Turn on DIP SW 1 on the printer control board.
3. Plug the IC card into the IC card adapter, then connect it to the option bus connector.  
**NOTE:** The Stinger - P3 has two option bus connectors. The left connector can only be used for this function.
4. Turn the printer on. The IC card boot service menu will be displayed.

#### *To exit the service mode*

1. Turn the printer off.
2. Remove the IC card and IC card adapter.
3. Turn DIP SW 1 to off.
4. Turn on the printer again.
5. Then, the user menu will appear.

**NOTE:** Don't forget to return DIP SW1 to the off position. Otherwise the printer will not boot.

### 4.3.3 IC CARD BOOT SERVICE MODE TREE

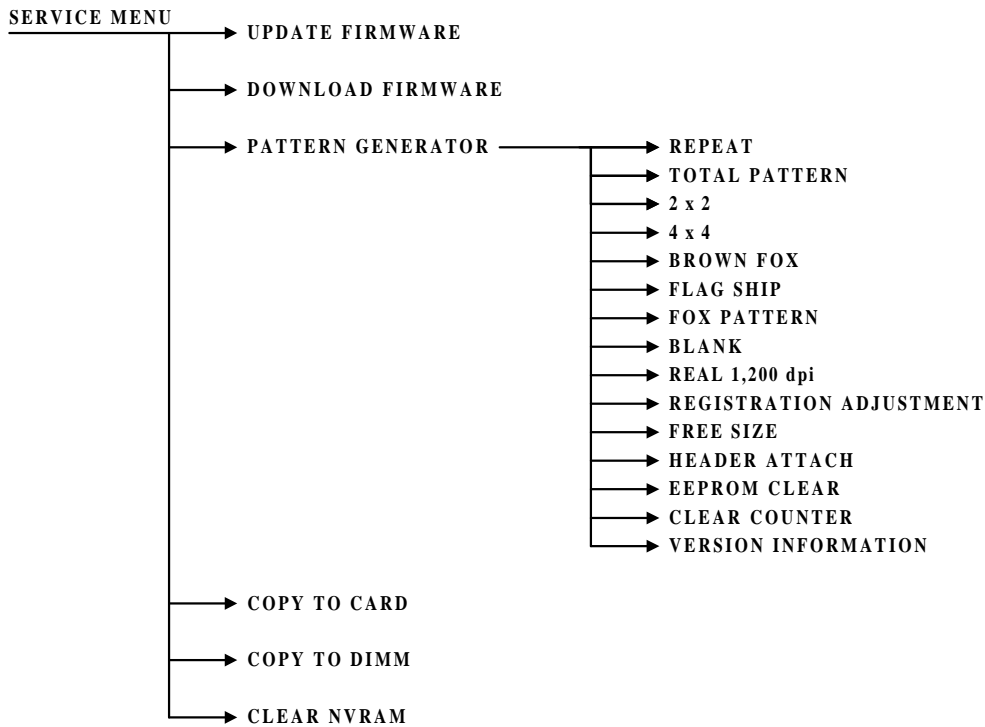

G031M526.WMF

#### ***Accessing the Required Program***

Select each program level in sequence.

1. Scroll through the 1st level programs using the “Up/Down arrow” keys. Then press the “Enter” key.
2. Scroll through the items in the next lowest level using the “Up/Down arrow” keys.
3. To go back to a higher level, press the “Escape” key.



### 4.3.4 SERVICE MENU TABLE

Menu Item	Function
Update Firmware	Update controller firmware using an IC card.
	For details, see the appendix, and "Downloading New Controller Software" in this section.
Download Firmware	Download firmware from a PC through a parallel cable.
	See the appendix for details.
Copy to DIMM	Download firmware to a DIMM card from a PC through a parallel cable.
	See the appendix for details.
Copy to CARD	Download firmware to an IC card from a PC through a parallel cable.
	See the appendix for details.
Clear NVRAM	Clear the NVRAM
	To clear the NVRAM, press the "Enter" key twice. Normally, NVRAM clear should not be used. <b>Note:</b> This resets all the settings stored in the NVRAM to their default settings. This procedure is required only after replacing the NVRAM chip.
TEST Print	Print controller generated test pattern (Factory use) See the appendix for details.

## 4.4 EEPROM AND NVRAM RESET PROCEDURES

The following table shows what data is stored in the EEPROM and NVRAM.

<b>EEPROM (ECB)</b>	<b>NVRAM (Printer Control Board)</b>
Registration settings	User settings for the controller
Transfer current settings	Product name (plug and play)
Image density	Controller serial number
Motor work time	Diagnostic error logging
Paper feed roller counter	Controller firmware version
Transfer roller counter	
Fusing unit counter	
Error logging	

**NOTE:** When the EEPROM or NVRAM is cleared, all the data in the memory shown above is cleared.

Memory clear procedures

- Service Program Mode - EEPROM Clear
- IC Card Boot Service Mode – NVRAM Clear

## 4.5 DOWNLOADING NEW CONTROLLER SOFTWARE

### 4.5.1 OVERVIEW

This section explains how to upgrade the controller firmware using an IC card, also known as a flash card. (Other methods are available for this model, and these are explained in the appendix.)

The engine board and NIB firmware cannot be upgraded in this way.

- The NIB has special procedures (see the manual for the NIB)
- The engine firmware is upgraded by changing the ROM.

The firmware has to be stored on the IC card in advance, either using SwapBox or the service tool menu. This is also covered in the appendix. (The service tool menu allows firmware to be copied from a PC, through a parallel cable, to an IC card plugged into the printer.)

To connect the IC card to the printer, an IC card adapter is required. This adapter plugs into one of the option bus connectors on the printer control board. The IC card adapter is provided as a service tool.

If power is interrupted during downloading, the printer can boot again with the previous firmware except if it happens while downloading the boot area. In this case, the printer must be booted with an IC card.

### 4.5.2 DOWNLOADING NEW FIRMWARE FROM AN IC CARD

#### Preparation

- IC card containing new firmware
- IC card adapter

#### Connecting the IC Card

##### Stinger - P3

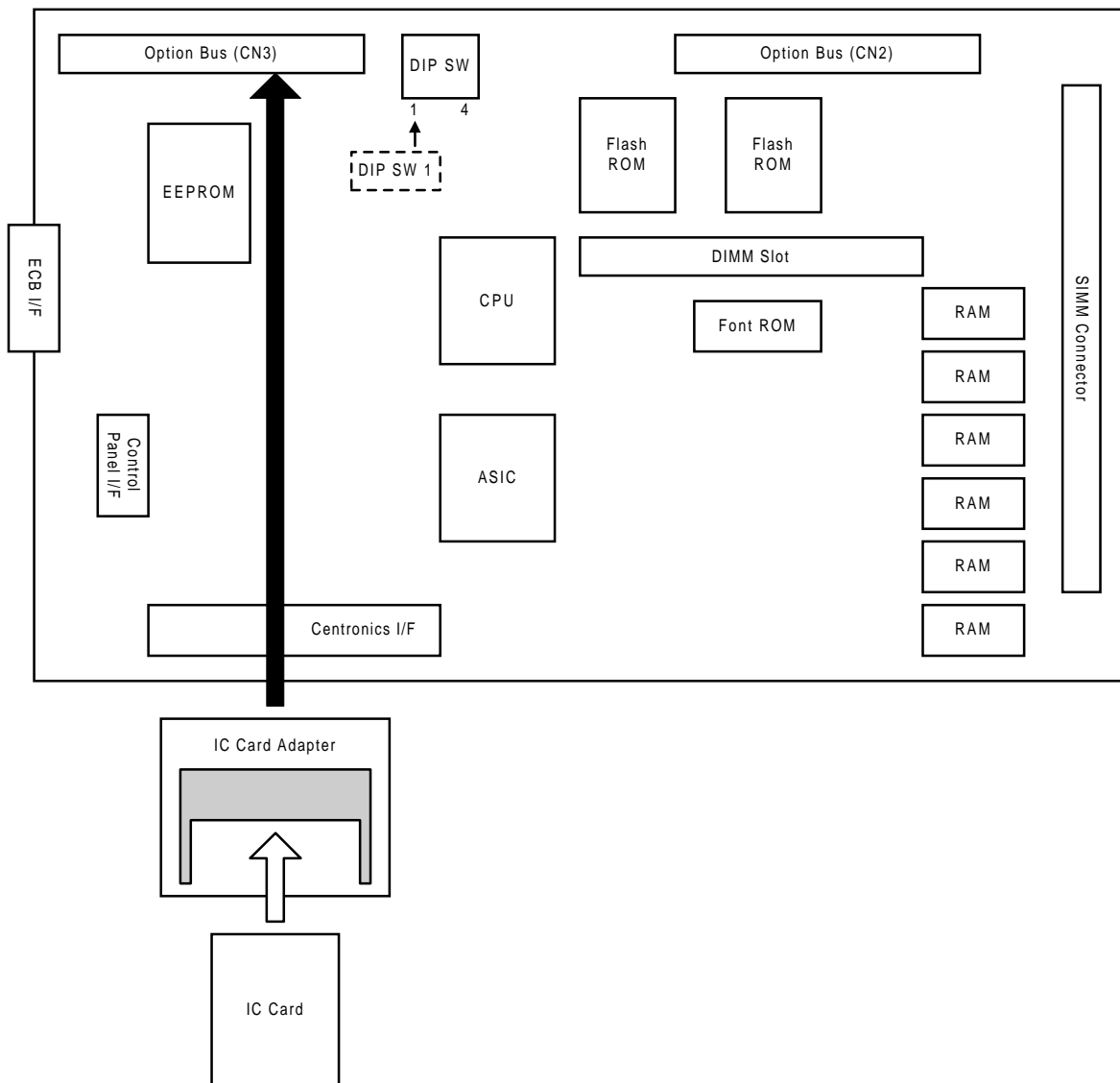

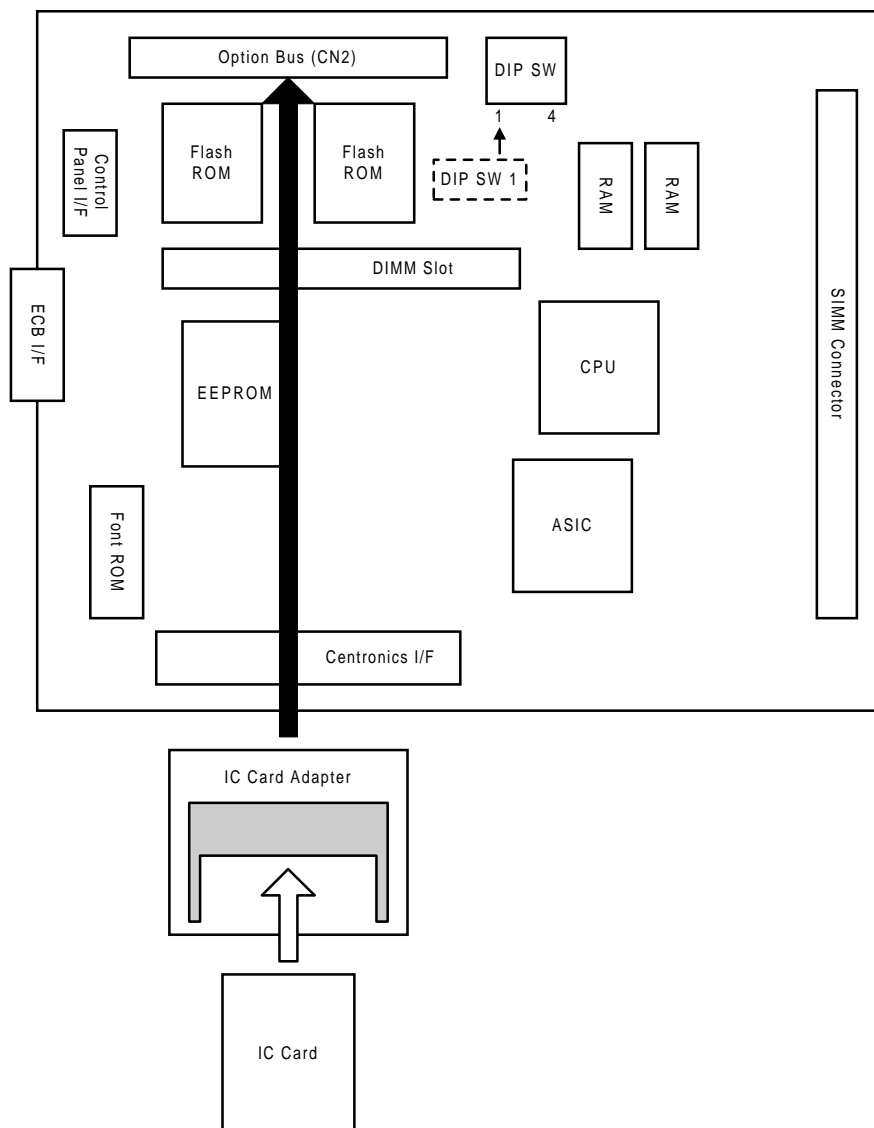
**Stinger - P4**

Service  
Tables

G031M503.WMF

**Downloading Procedure**

1. Turn off the printer.
2. Change DIP SW1 to ON on the printer control board.
3. Attach the IC card to the IC card adapter, then plug the adapter into the option bus connector.  
**NOTE:** Stinger - P3 has two option bus connectors. Only the connector on the left side can be used for downloading.
4. Turn on the printer. The printer will boot from the firmware in the IC card.  
**NOTE:** Don't use a blank IC card. Otherwise the printer will not boot up.

5. The service menu will appear as follows. Do the following step by step.

Stinger Service  
1. Update Firm

G031M509.WMF

Press the "Enter" key.

1. Update Firm  
Sure?

G031M529.WMF

Press the "Form Feed" key.

Stinger Firm ver  
Wait 62

G031M530.WMF

The counter on the display counts down to zero.

Stinger Firm ver  
Successful

G031M531.WMF

6. The above display shows that updating has finished.
7. Turn off the printer.
8. Detach the IC card and the IC card adapter.
9. Change DIP SW1 to off.
10. Turn the printer on and enter the service program mode.
11. Print the log print and check the controller firmware version.
12. Return to the user mode.

**NOTE:** There are two ways to go back to the user mode from the service mode.

- 1) Press the "Form Feed" key and the "Escape" key together. Then initialization will start.
- 2) Turn the printer off and on.

### 4.6 USER MENU

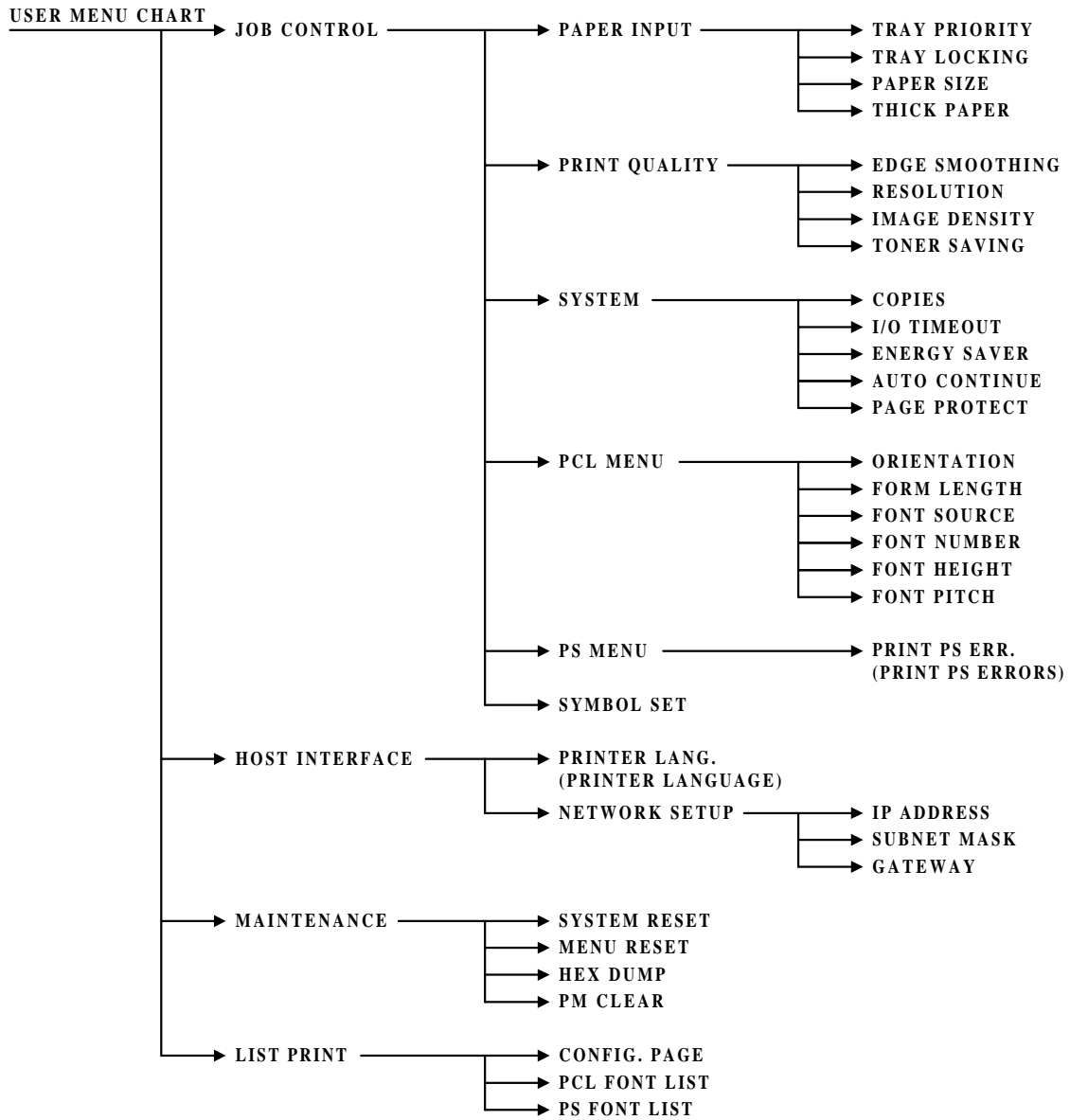

Service Tables

G031M507.WMF

## 4.7 ECB TEST PATTERN

When the TB1 pins on the ECB board are shorted, the lattice test pattern is printed out from the ECB board. This test pattern does not use the printer control board. This test helps to find whether the problem is caused by the ECB or the printer control board.

The location of TB1 is as shown below.

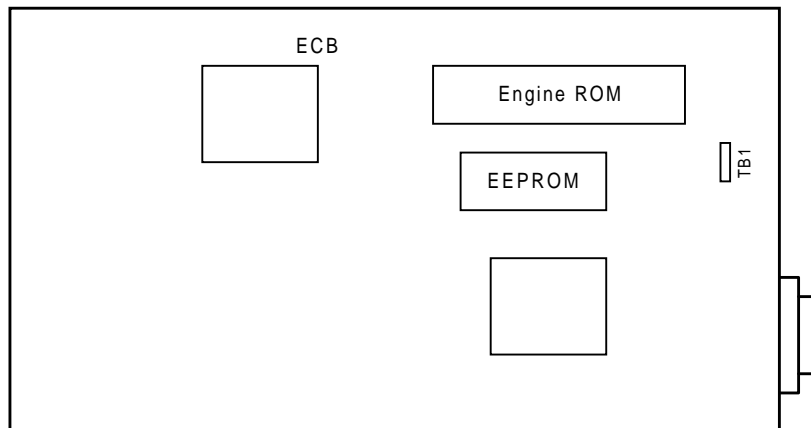

G031M527.WMF

### ***Procedure***

1. Turn the printer on.
2. Short the TB1 pins.
3. The test pattern is automatically printed out.



## 4.8 DIAGNOSTIC TEST MODES

### 4.8.1 OVERVIEW

This machine has two types of diagnostic test mode.

- Power-up diagnostics: Done every time the machine is switched on
- Detailed diagnostics: Done after entering the detailed diagnostic mode

### 4.8.2 POWER-UP DIAGNOSTIC MODE

This is automatically done to check system integrity whenever the machine is powered up.

If the Power LED blinks during this test, the test is proceeding without problems.

If the Power LED does not blink during the test, it means that a fatal error has occurred. If the machine detects an error, the machine displays an SC code (e.g. SC 2100) on the operation panel, turns off the Power LED, blinks the Error LED, and stops system booting.

If the error is for an optional device (if one of the following SCs is displayed), switch off the power, disconnect the defective optional device, then turn the power back on. The machine will restart.

SC Code	Optional Device
SC2600	HDD
SC2700	NIB
SC2800	DIMM
SC2900	RS232C
SC3100	SIMM
SC3200	Unknown Option
SC3201	Unknown Option

### **4.8.3 DETAILED DIAGNOSTIC MODE**

#### ***Entering Detailed Diagnostic Mode***

To enter this mode, turn the machine off and on while pressing the “On Line” key and the “Enter” key together.

#### ***During the Test***

While testing, the machine displays the component being tested.

If the Power LED blinks, the test is proceeding without problems.

If the Power LED does not blink, a fatal error has occurred. If the machine has detected an error, the machine displays the error code (e.g. 0101) on the operation panel, turns off the Power LED, blinks the Error LED, and stops the test.

If an error occurs during the test, press the “Escape” key and the “Form Feed” key together to continue the test. However, if the error is one of those in the ‘Power-up and Detailed Diagnostics Modes – Program Execution Errors’ table (see section 7, ‘Troubleshooting’), the test cannot continue.

If the Centronics or RS232C loopback connector is not plugged in, an error will occur for the device with the missing connector

#### ***Print Log Output***

The print log is printed automatically after the detailed diagnostic test has finished.

#### 4.8.4 DIAGNOSTIC TEST DETAILS

Item	Mode		Function
	Normal	Detail	
<b>Always executed</b>			
VR4300 (CPU) Timer	✓	✓	Tests the timer of the CPU
Code ROM	✓	✓	Tests the code ROM
Resident DRAM	✓	✓	Tests the resident DRAM
VR4300 Exception	✓	✓	Tests the exception interrupt function of the CPU
VR4300 Cache	✓	✓	Tests the cache memory of the CPU
VR4300 FPU	✓	✓	Tests the FPU of the CPU
ASIC Timer	✓	✓	Tests the timer of the ASIC
NVRAM	✓	✓	Tests the NVRAM
ASIC P1284	✗	✓	Tests the parallel interface (IEEE1284)
ASIC Engine I/F	✓	✓	Tests the engine control board I/F of the ASIC
Font ROM	✓	✓	Tests the font ROM
ASIC PVDMA	✓	✓	Tests the PVDMA of the ASIC
<b>Executed if they are installed</b>			
Optional SIMM	✓	✓	Tests the SIMM
HDD	✓	✓	Tests the HDD
NIB	✓	✓	Tests the NIB
RS232C Loopback Test	✓	✓	Makes a serial interface loopback test (RS232C)

The option tests are executed only if these devices are detected.

The parallel and the RS232C loopback tests require the loopback connectors to be connected. If these connectors are not attached, the tests for these components will result in an error.

**Loopback Connector for the Centronics Interface**

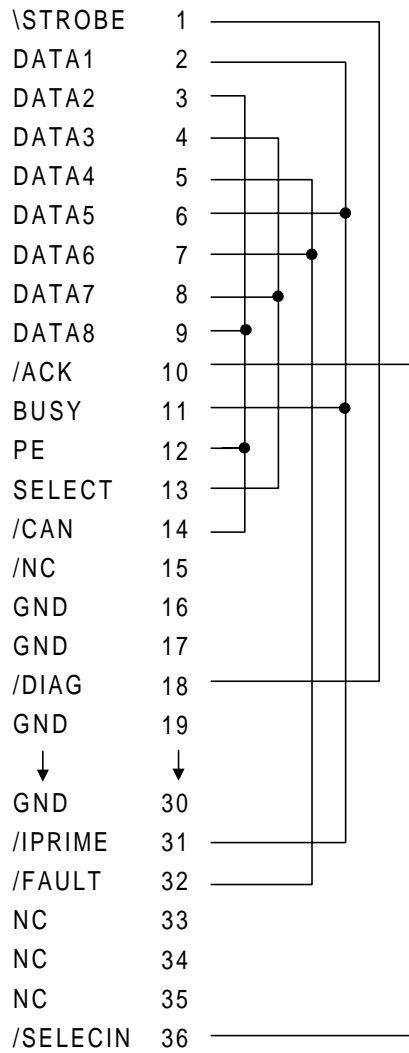

G031M504.WMF

**Loopback Connector for the RS232C Interface**

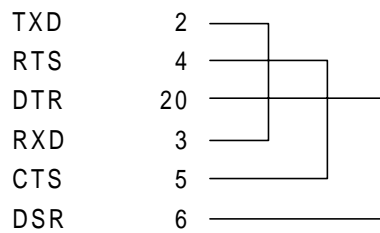

G031M505.WMF

## 5. PREVENTIVE MAINTENANCE

### 5.1 PREVENTIVE MAINTENANCE SCHEDULE

All PM will be done by the user. A maintenance kit is available for the user.

The maintenance kit contains the following items.

- Fusing Unit
- Transfer Roller
- Paper Feed Roller (3 pcs for the Stinger - P3, 1 pc for the Stinger - P4)
- Friction Pad

When the maintenance counter reaches 80 for the Stinger - P3 and 60 for the Stinger - P4, "REPLACE MAINTENANCE KIT" is displayed.

After replacing the parts in the maintenance kit for the Stinger - P4, PM clear in the user's maintenance menu is required to reset the display. This is not needed for the Stinger - P3, because the Stinger – P3 automatically resets the display when it detects the new fusing unit.

Symbol key: C: Clean, R: Replace, L: Lubricate, I: Inspect

Item	PM		EM	Remarks
	Stinger - P3 80	Stinger - P4 60		
<b>Main Frame</b>				
Fusing Unit	R	R		
Transfer Roller	R	R		
Paper Feed Roller	R	R	C	Clean with water
Friction Pad	R	R	C	Clean with water
Registration Roller (Stinger-P3)			C	Clean with water
Shield Glass			C	Clean with water
Bypass Tray Paper Feed Roller			C	Clean with water
Bypass Tray Friction Pad			C	Clean with water
Relay Roller (Stinger - P4)			C	Clean with water
<b>Paper Feed Unit</b>				
Paper Feed Roller	R		C	Clean with water
Friction Pad			C	Clean with water
Drive Roller			C	Clean with water

Preventive Maintenance

## 6. REPLACEMENT AND ADJUSTMENT

### 6.1 COVERS

#### 6.1.1 EXTERIOR COVER REMOVAL

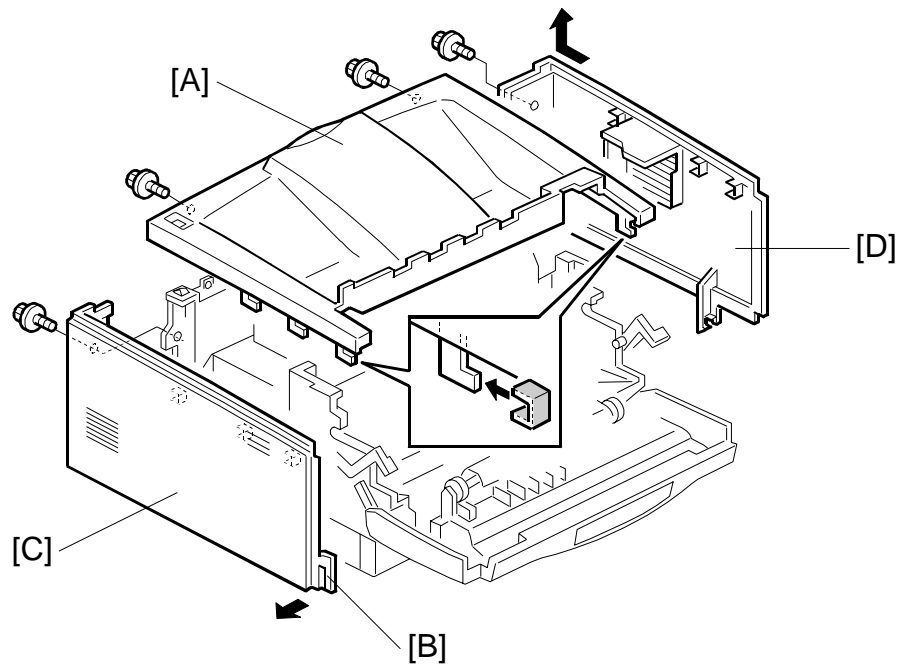

G031R507.WMF

#### **Stinger - P3**

1. Remove the fusing unit. (Refer to Fusing Unit Replacement, section 6.2.1.)
2. Remove the top cover [A] (two screws).
3. Pull the hook [B] towards the outside, then remove the left cover [C] (1 screw).
4. Slightly shift the right cover [D] towards the rear, then remove it (1 screw).

#### **Stinger - P4**

**NOTE:** Before removing the exterior covers, remove the printer from the paper feed unit (if the optional paper feed unit is installed).

1. Remove the fusing unit. (Refer to Fusing Unit Replacement, section 6.2.1.)
2. Remove the top cover [A] (two screws).
3. Slightly pull out the paper tray.
4. Remove the left and right covers [B, D] (1 screw each).

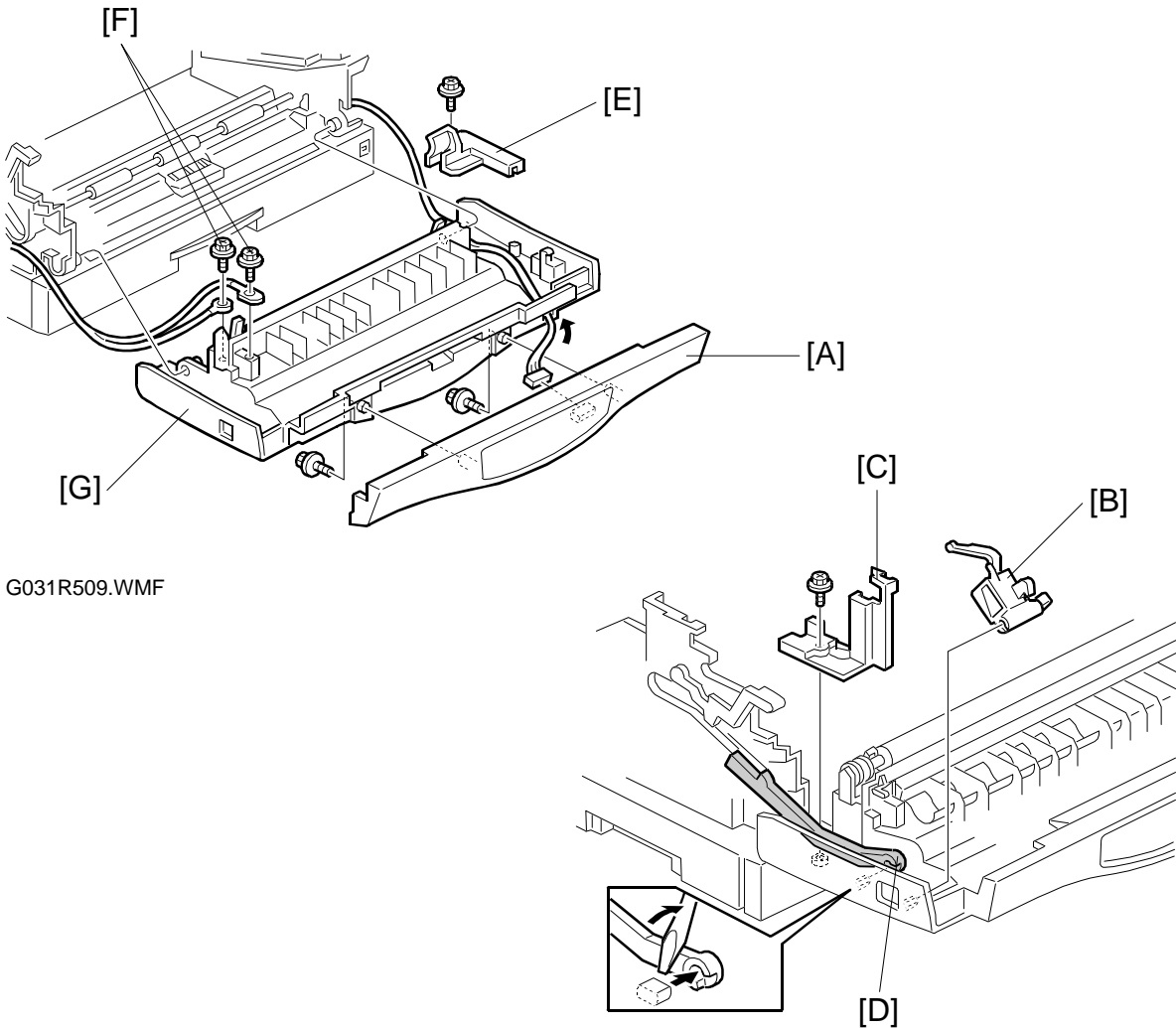
**6.1.2 FRONT COVER REMOVAL**

G031R509.WMF

G031R508.WMF

1. Remove the by-pass tray. (Refer to By-pass Tray Removal, section 6.4.1.)
2. Open the front cover.
3. Remove the operation panel [A] (2 screws and 1 connector).
4. Remove the lock lever [B].
5. Remove the cable cover [C] (1 screw).
6. Release the shutter arm [D] as shown.
7. Remove the clamp (Stinger - P3, 1 screw) or cable cover [E] (Stinger - P4, 1 screw).
8. Remove the two screws [F] securing the cables.
9. Remove the front cover [G].

### 6.1.3 CONTROL BOARD COVER REMOVAL

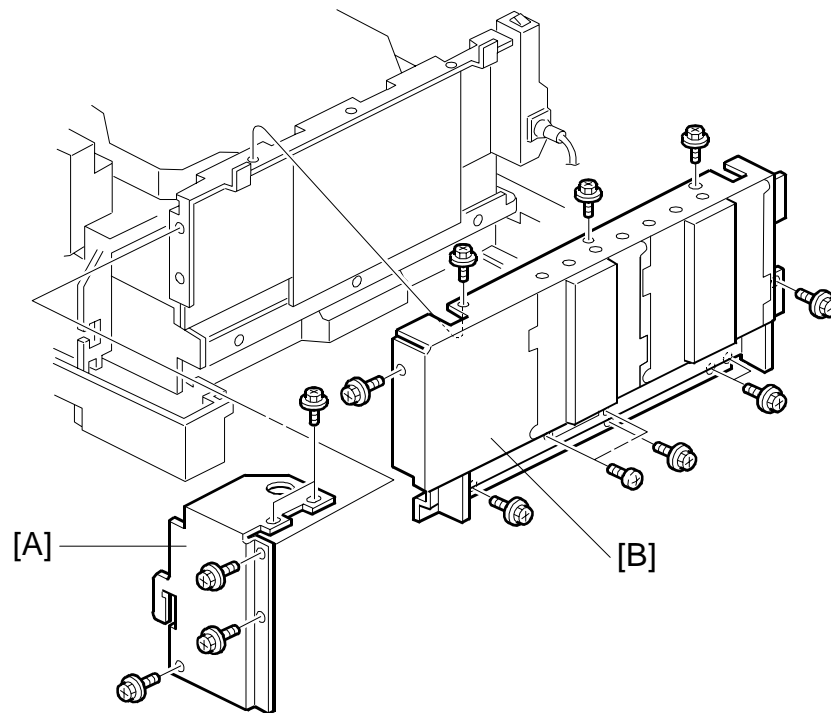

G031R510.WMF

1. Remove the top, left and right covers. (Refer to Exterior Cover Removal, section 6.1.1.)
2. Remove the shielding plate [A] (5 screws, Stinger - P3 only).
3. Remove the control board cover [B] (11 screws).

Replacement  
Adjustment



## 6.2 FUSING UNIT

### 6.2.1 FUSING UNIT REPLACEMENT

**⚠ CAUTION**

Be careful when removing the fusing unit, because it could be very hot.

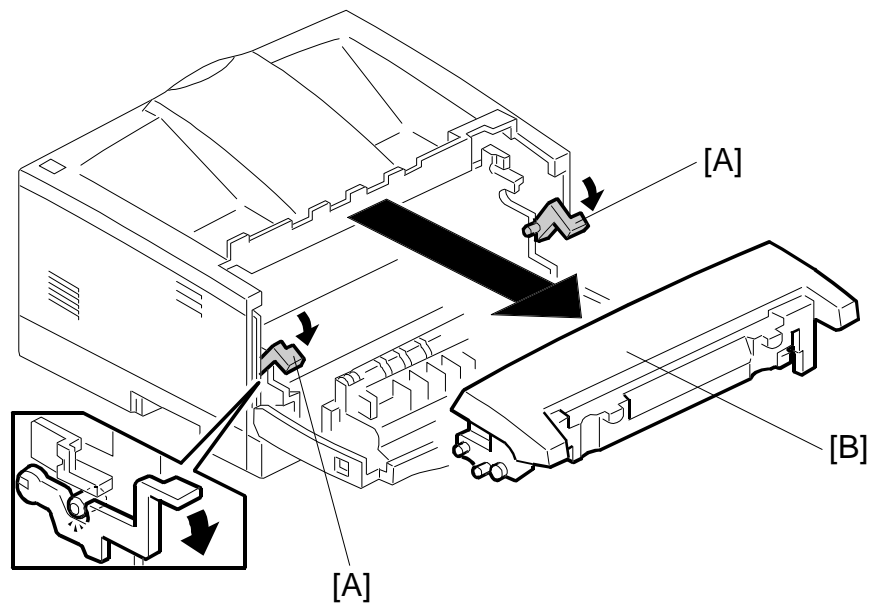

G031R511.WMF

1. Turn off the main switch.
2. Open the front cover.
3. Release the levers [A] as shown.
4. Replace the fusing unit [B].
5. Perform the PM clear (except after installing the fusing unit in the Stinger - P3 maintenance kit).
  - User Menu – Maintenance – PM Clear

## 6.2.2 HOT ROLLER AND FUSING LAMP REPLACEMENT

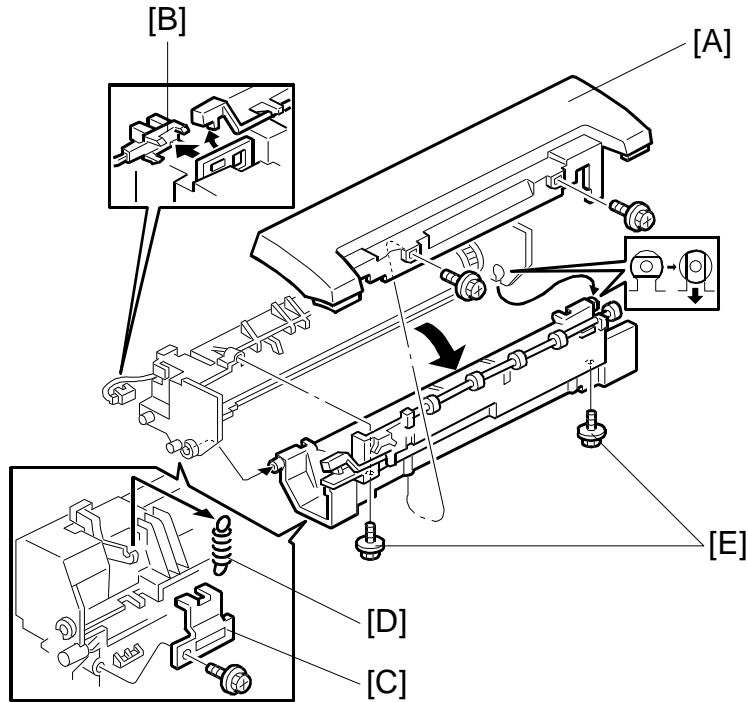

G031R542.WMF

1. Remove the fusing unit. (Refer to Fusing Unit Replacement, section 6.2.1.)
2. Remove the fusing cover [A] (2 screws).
3. Remove the fusing exit sensor [B].
4. Remove the bracket [C] and the spring [D]. (Stinger - P3 has two brackets [C] and two springs [D], Stinger - P4 has one of each.)
5. Separate the fusing unit (2 screws [E]).

Replacement  
Adjustment

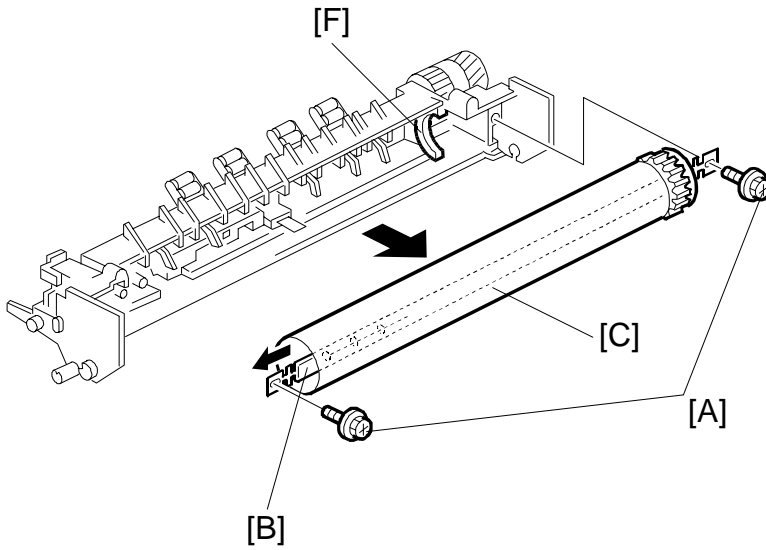

G031R512.WMF

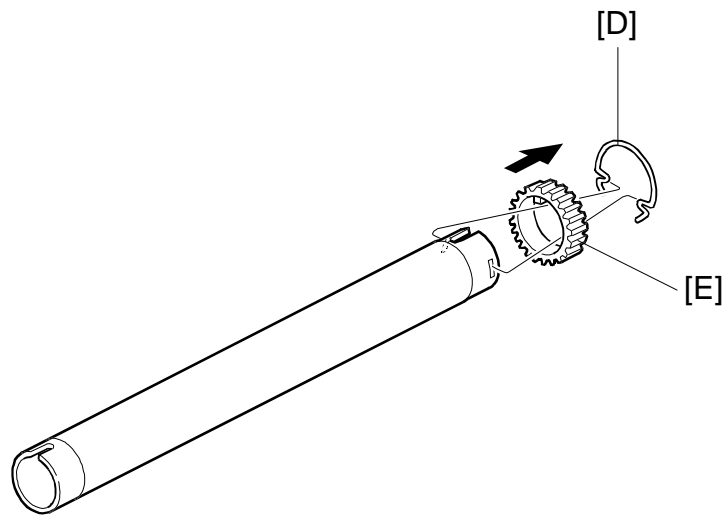

G031R547.WMF

6. Remove the two screws [A] securing the terminals.
7. Replace the fusing lamp [B].  
**NOTE:** Do not touch the fusing lamp with your bare hands.
8. Replace the hot roller [C] (1 C-ring [D] and 1 gear [E]).  
**NOTE:** 1) Be careful not to scratch the hot roller with the stripper pawls.  
 2) Do not touch the hot roller with your bare hands.  
 3) When re-installing the hot roller, make sure that the bushing [F] is in the correct place, as shown.

### 6.2.3 PRESSURE ROLLER REPLACEMENT

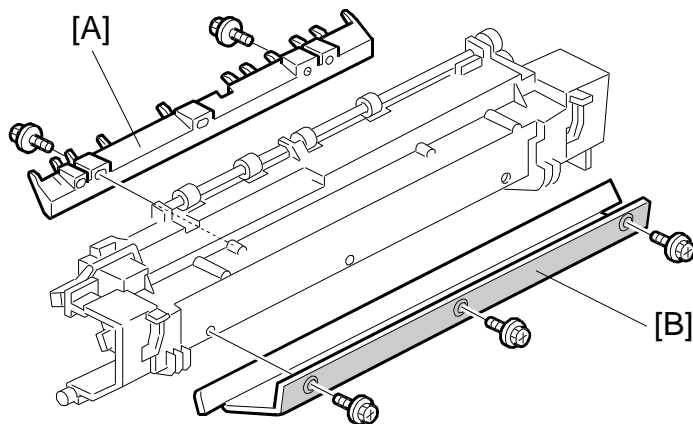

G031R555.WMF

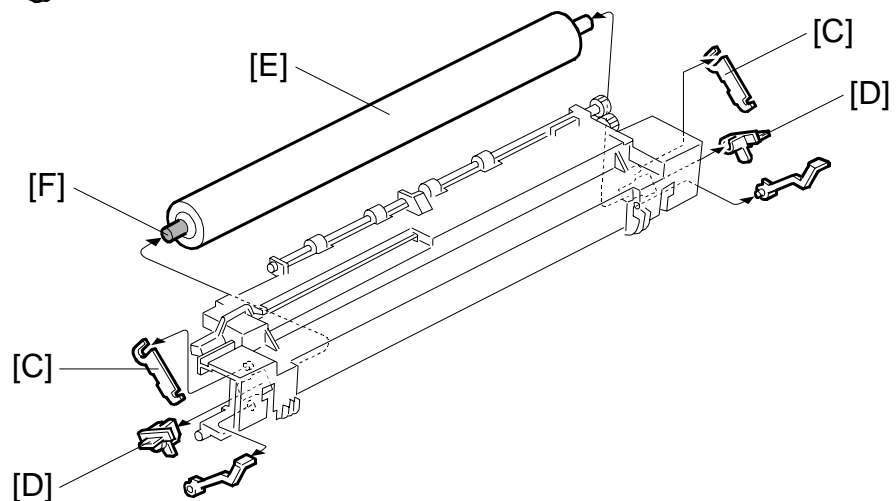

G031R543.WMF

1. Perform steps 1 to 5 of Hot Roller and Fusing Lamp Replacement, section 6.2.2.
2. Stinger – P3 only: Remove the exit guide plate [A] (2 screws).
3. Stinger – P3 only: Remove the entrance guide [B] (3 screws).
4. Remove the pressure arms [C].
5. Remove the bushings [D].
6. Replace the pressure roller [E].

**NOTE:** 1) When re-installing the pressure roller, make sure that the green pin [F] is at the left side, as shown (near the fusing exit sensor).  
 2) Do not touch the pressure roller with your bare hands.

Replacement  
Adjustment

## 6.2.4 FUSING THERMOFUSE REPLACEMENT

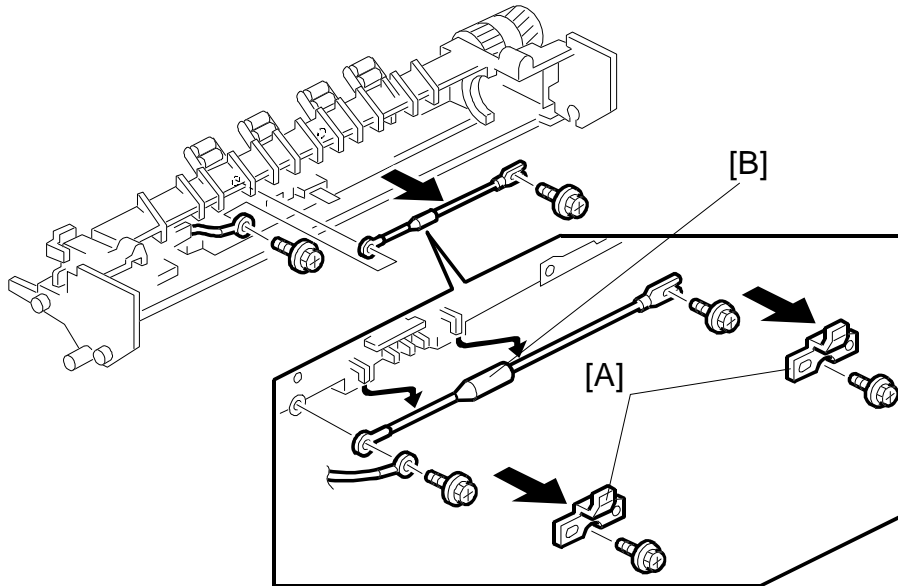

G031R544.WMF

1. Remove the hot roller. (Refer to Hot Roller and Fusing Lamp Replacement, section 6.2.2.)
2. Remove the two screw covers [A] (230 V machine only, 1 screw each).
3. Replace the fusing thermofuse [B] (2 screws).

## 6.2.5 FUSING DRAWER CONNECTOR REPLACEMENT

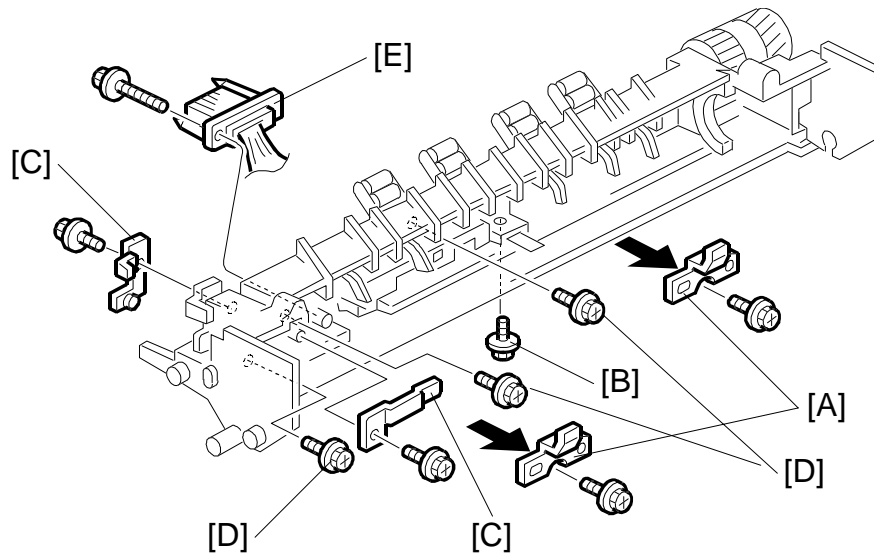

G031R545.WMF

1. Remove the hot roller. (Refer to Hot Roller and Fusing Lamp Replacement, section 6.2.2.)
2. Remove the two screw covers [A] (230 V machine only, 1 screw each).
3. Remove the screw [B] securing the thermistor.
4. Remove the two cable covers [C] (1 screw each).  
**NOTE:** When re-installing the cable covers, secure the cable under the cover correctly.
5. Remove the three screws [D] securing the cable.
6. Replace the fusing drawer connector [E] (1 screw).

Replacement  
Adjustment

## 6.3 TRANSFER ROLLER

### 6.3.1 TRANSFER ROLLER REPLACEMENT

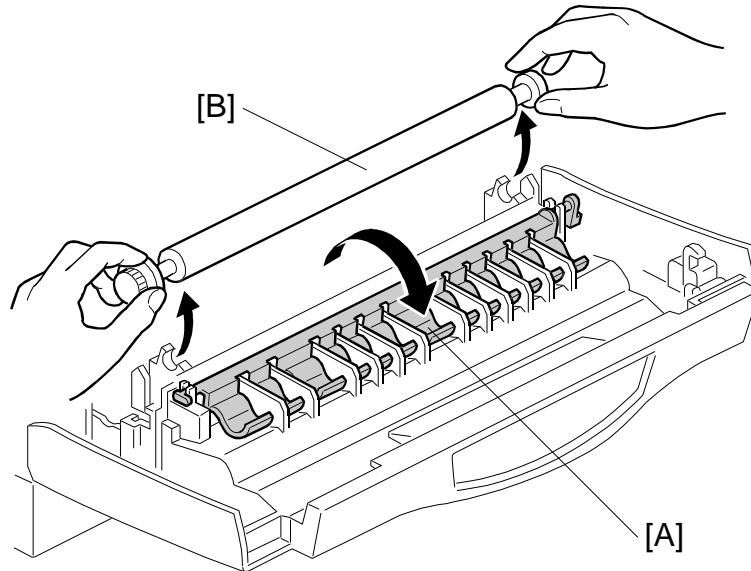

G031R513.WMF

1. Open the front cover.
2. Open the transfer roller cover [A].
3. Replace the transfer roller [B].

**NOTE:** Do not touch the transfer roller with your bare hands.

## 6.4 PAPER FEED

### 6.4.1 BY-PASS TRAY REMOVAL

#### - Stinger - P3 -

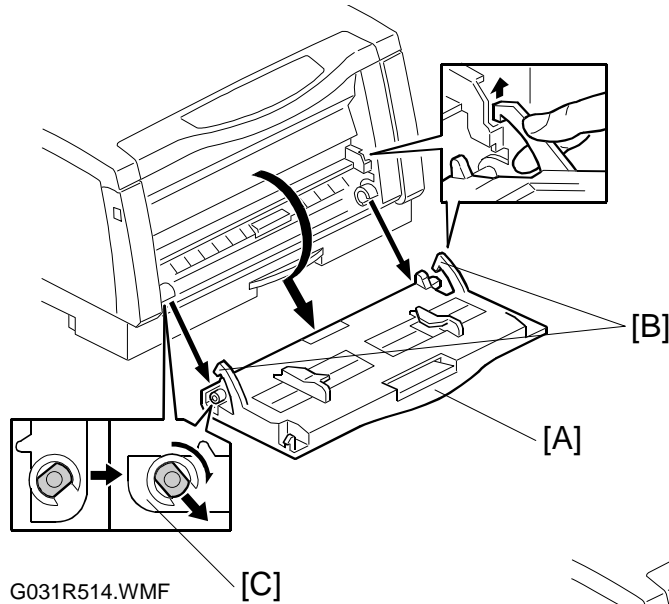

#### - Stinger - P4 -

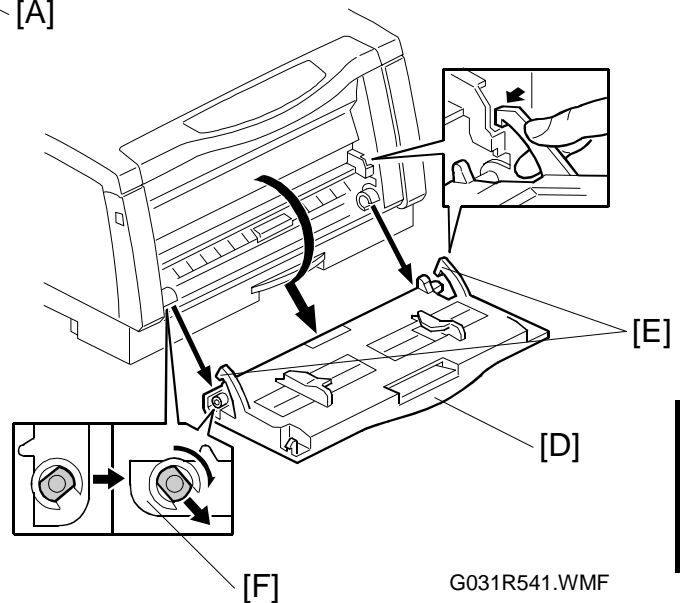

Replacement  
Adjustment

#### **Stinger - P3**

1. Open the by-pass tray [A].
2. While lifting the hooks [B], lower the by-pass tray and remove it as shown [C].

#### **Stinger - P4**

1. Open the by-pass tray [D].
2. Draw out the paper cassette.
3. While moving the hooks [E] inwards, lower the by-pass tray and remove it as shown [F].



## 6.4.2 BY-PASS FEED ROLLER REPLACEMENT

### *Stinger - P3*

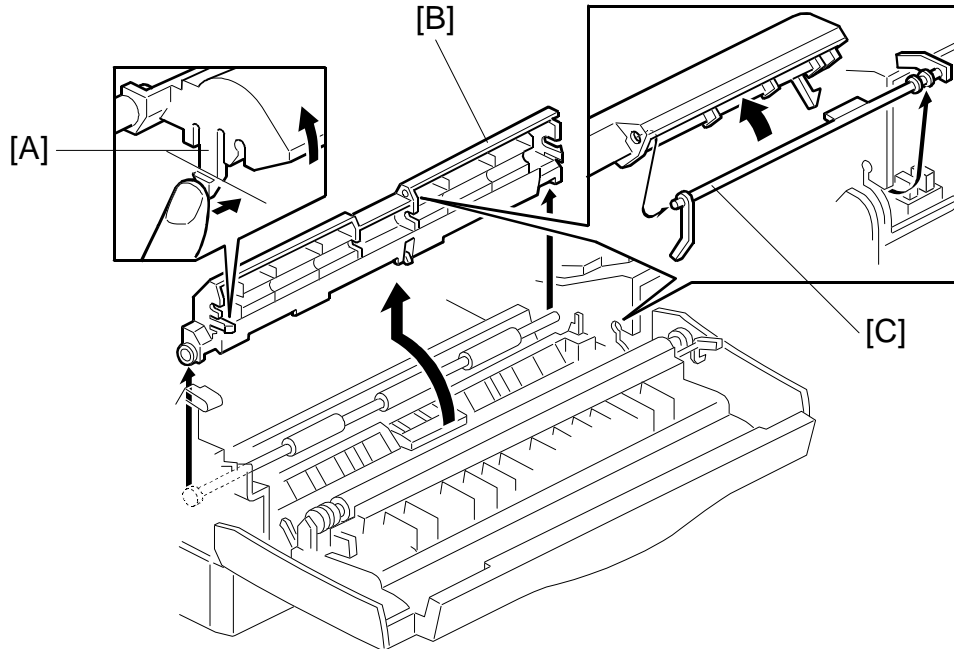

G031R515.WMF

1. Remove the right cover. (Refer to Exterior Cover Removal, section 6.1.1.)
2. While releasing the hook [A], remove the by-pass feed roller cover [B], as shown.  
**NOTE:** Remove the by-pass feed roller cover carefully (it is attached tightly). Otherwise, the feeler [C] may be damaged.
3. Remove the feeler [C].

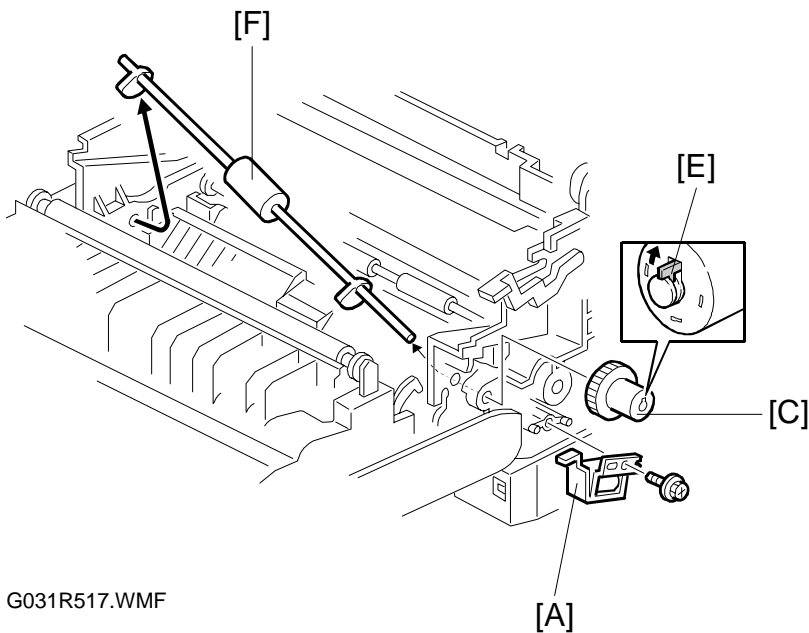

G031R517.WMF

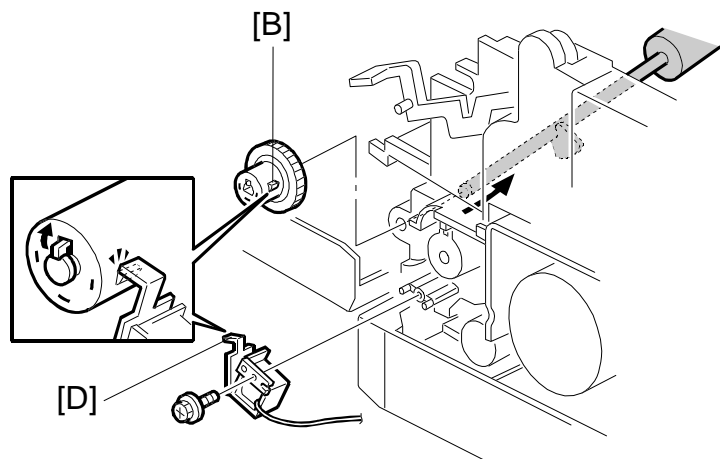

G031R516.WMF

Replacement  
Adjustment

4. Remove the by-pass feed solenoid [A] (1 screw).  
**NOTE:** When reinstalling the by-pass feed solenoid, make sure that the projection [B] on the by-pass feed clutch [C] touches the underside of the bracket [D].
5. While unhooking the hook [E] from the by-pass feed clutch, remove the by-pass feed roller [F], as shown.  
**NOTE:** Do not touch the by-pass feed roller with your bare hands.

**Stinger - P4**

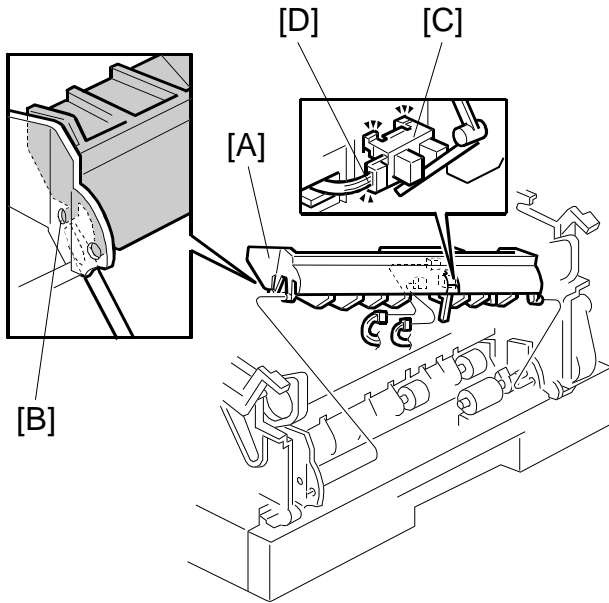

G031R518.WMF

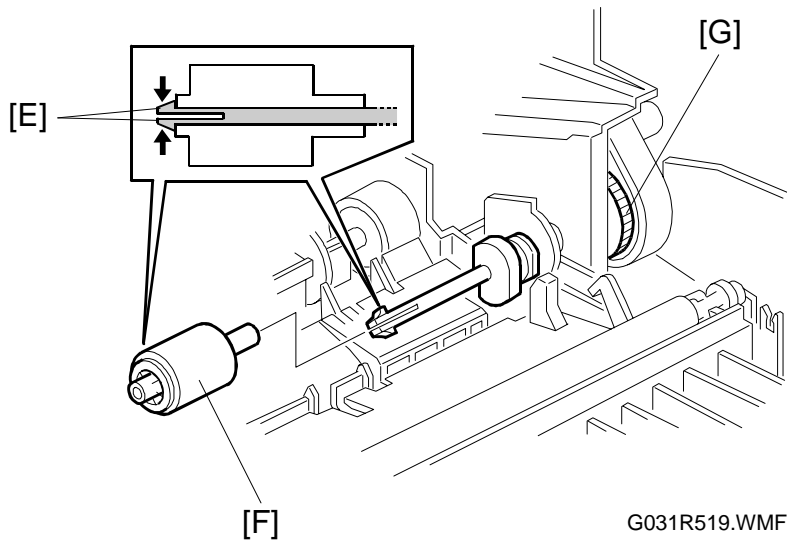

G031R519.WMF

1. Remove the front cover. (Refer to Front Cover Removal, section 6.1.2.)
2. Remove the by-pass feed roller cover [A], as shown.
 

**NOTE:** 1) First, unhook the left rear hook [B].  
 2) When re-installing the by-pass feed roller cover, make sure that the sensor [C] and connector [D] are connected together and attached to the frame, as shown.
3. While unhooking the hooks [E], remove the by-pass feed roller [F], as shown.
 

**NOTE:** 1) Do not touch the by-pass feed roller with your bare hands.  
 2) While pushing the gear [G] towards the inside of the machine, re-install the by-pass feed roller.

### 6.4.3 PAPER FEED ROLLER REPLACEMENT

*Stinger - P3*

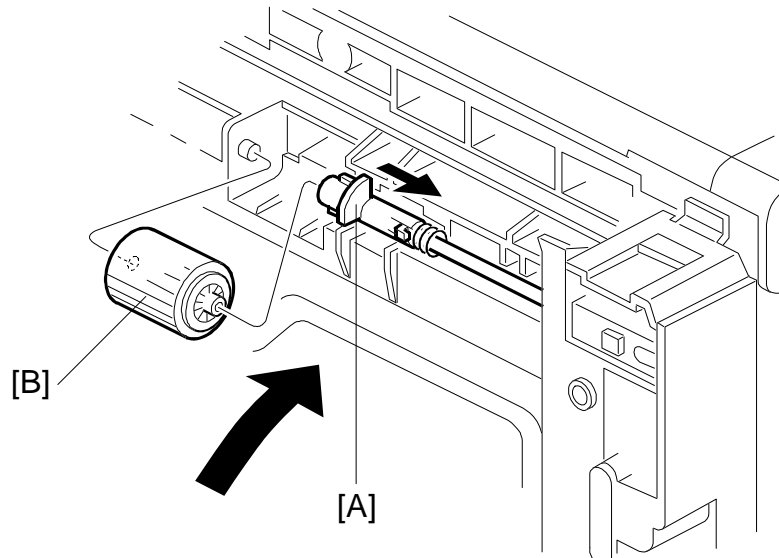

G031R520.WMF

1. Draw out the paper cassette.
2. While releasing the spring mechanism [A], remove the paper feed roller [B].  
**NOTE:** Do not touch the paper feed roller with your bare hands.

Replacement  
Adjustment

**Stinger - P4**

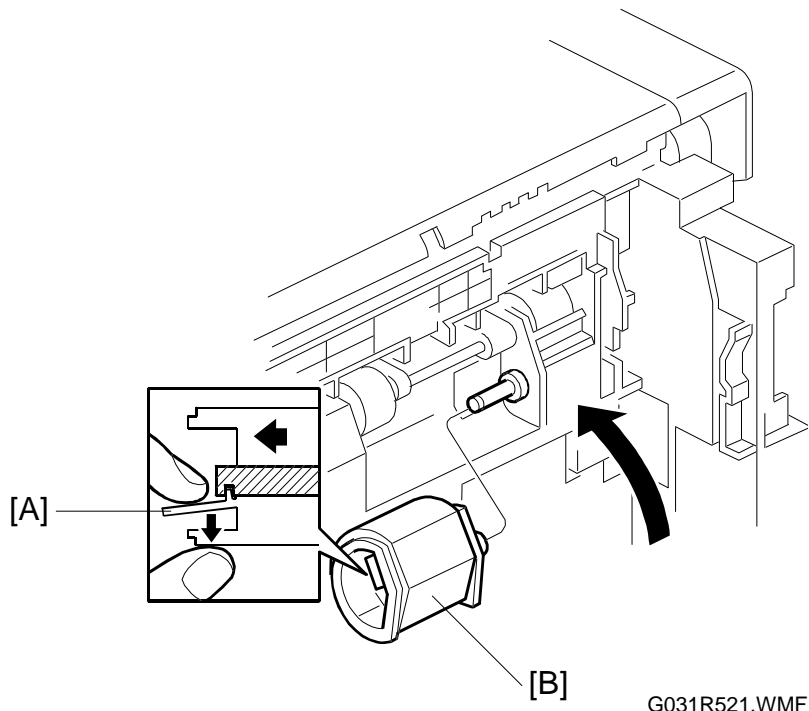

1. Draw out the paper cassette.
2. While releasing the hook [A], remove the paper feed roller [B].  
**NOTE:** Do not touch the paper feed roller with your bare hands.

### 6.4.4 RELAY ROLLER REPLACEMENT (STINGER - P4 ONLY)

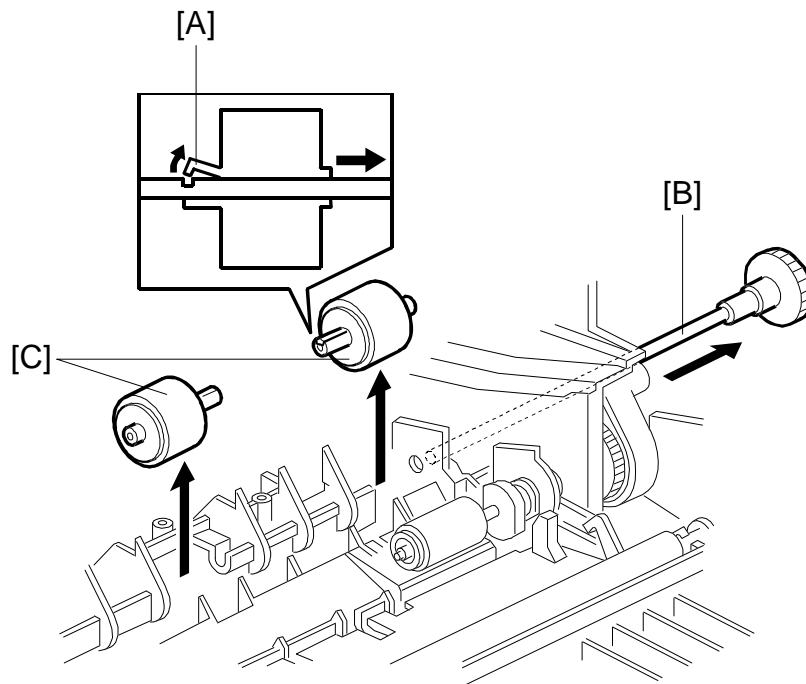

G031R522.WMF

1. Remove the by-pass feed roller cover. (Refer to By-pass Feed Roller Replacement, section 6.4.2.)
2. While unhooking the hooks [A], pull the shaft [B] out to the right.
3. Replace the relay rollers [C].

**NOTE:** Do not touch the relay rollers with your bare hands.

Replacement  
Adjustment

## 6.4.5 FRICTION PAD REPLACEMENT

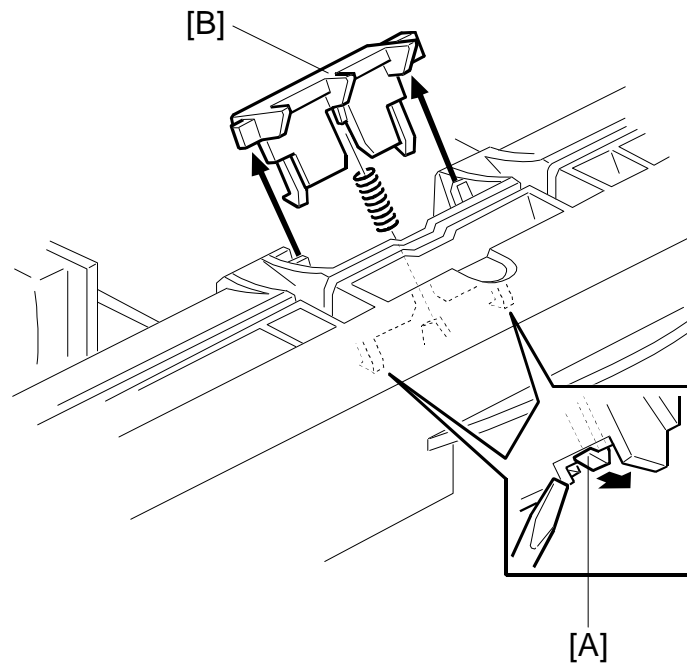

G031R523.WMF

1. Draw out the paper cassette.
2. Remove the paper from the paper tray. Turn the tray upside down and place it on a flat surface.
3. While unhooking the hooks [A], remove the friction pad [B], as shown.

**NOTE:** Be sure to unhook the hooks. Otherwise, they may be broken.

## 6.4.6 TRAY PAPER FEED CLUTCH REPLACEMENT

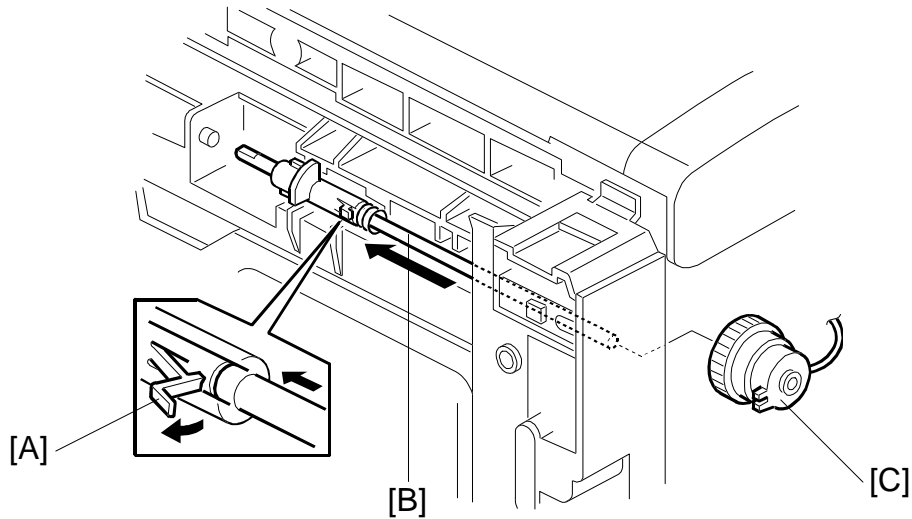

G031R524.WMF

1. Remove the control board cover. (Refer to Control Board Cover Removal, section 6.1.3.)
2. Remove the paper feed roller. (Refer to Paper Feed Roller Replacement, section 6.4.3.)
3. While unhooking the hook [A], pull the shaft [B] out to the left.
4. Replace the tray paper feed clutch [C] (1 connector on the engine control board).

**Replacement  
Adjustment**



## 6.5 LASER UNIT

<p><b>⚠ WARNING</b></p> <p>Turn off the main switch and unplug the machine before attempting any of the procedures in this section. Laser beams can seriously damage your eyes.</p>
---

### 6.5.1 CAUTION DECAL LOCATIONS

Caution decals are located in the laser section as shown below.

- Stinger - P3 -

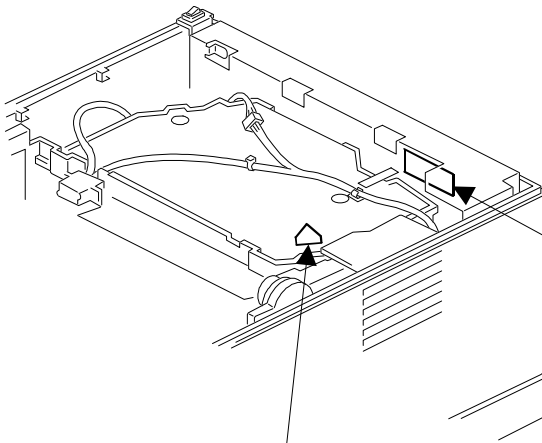

G031R501.WMF

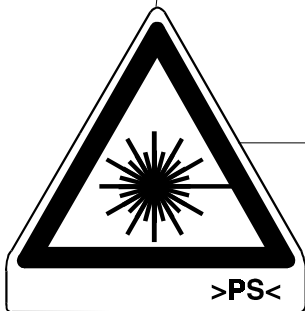

- Stinger - P4 -

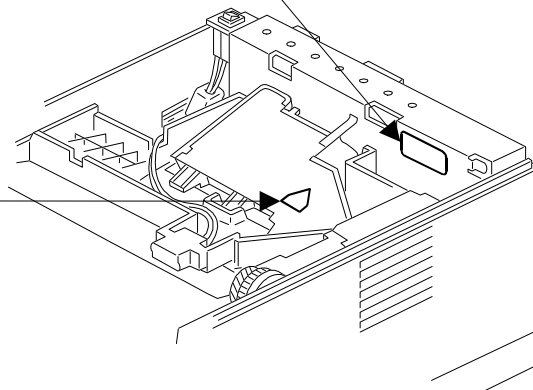

G031R500.WMF

## 6.5.2 LASER UNIT/SHIELD GLASS REPLACEMENT

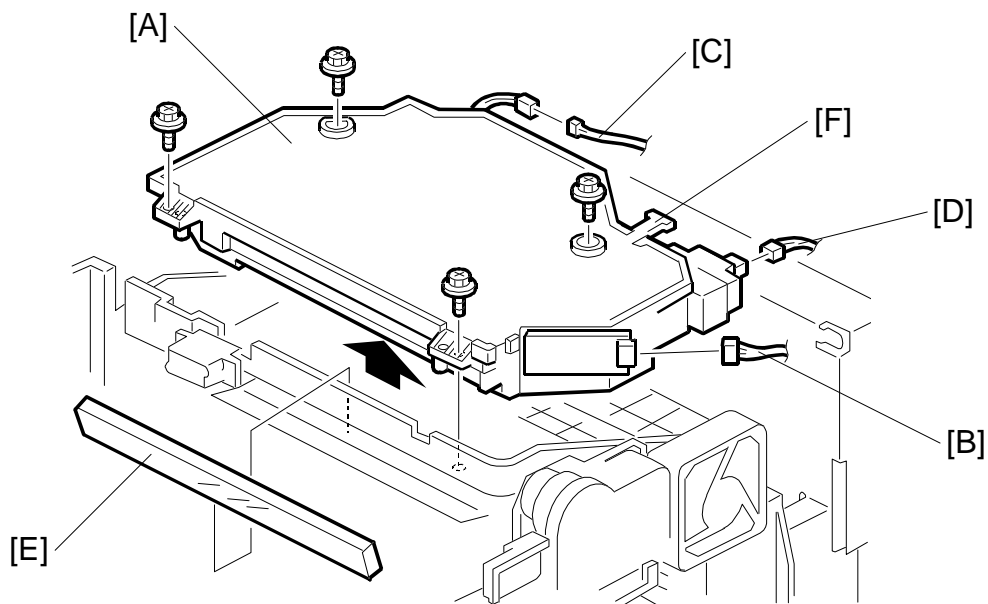

G031R502.WMF

### **Laser Unit**

1. Remove the top cover. (Refer to Exterior Cover Removal, section 6.1.1.)
2. Remove the laser unit [A] (4 screws and 3 connectors [Stinger - P3] or 2 connector [Stinger - P4]).

**NOTE:** 1) Disconnect connectors [B] and [C] first. When connector [D] is accessible, disconnect it.

- 2) When removing or re-installing the laser unit, make sure not to damage the shield glass [E] located just under the unit.

### **Shield Glass**

1. Remove the laser unit as described above.
2. Replace the shield glass [E].

 Replacement  
Adjustment

### 6.5.3 LD UNIT/LASER SYNCHRONIZATION DETECTOR REPLACEMENT

#### *Stinger - P3*

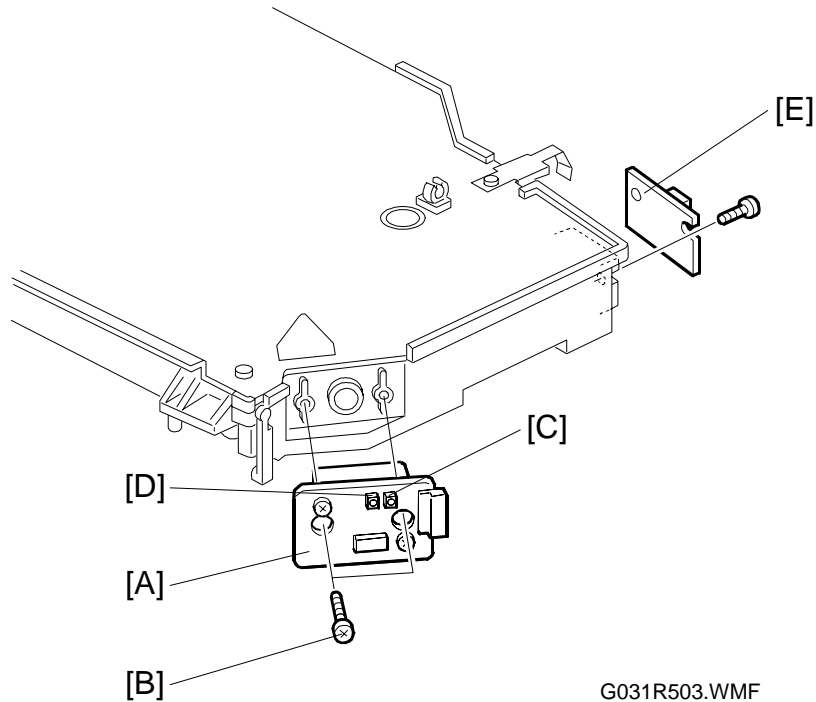

G031R503.WMF

#### *LD Unit*

1. Remove the laser unit. (Refer to Laser Unit/Shield Glass Replacement, section 6.5.1.)
2. Replace the LD unit [A] by removing the screws [B] as shown.

**NOTE:** Do not touch VR101 [C] and VR102 [D], because they are adjusted in the factory before shipment.

#### *Laser Synchronization Detector*

1. Remove the laser unit. (Refer to Laser Unit/Shield Glass Replacement, section 6.5.1.)
2. Replace the laser synchronization detector [E] (1 screw).

## 6.5.4 POLYGONAL MIRROR MOTOR REPLACEMENT

### *Stinger - P3*

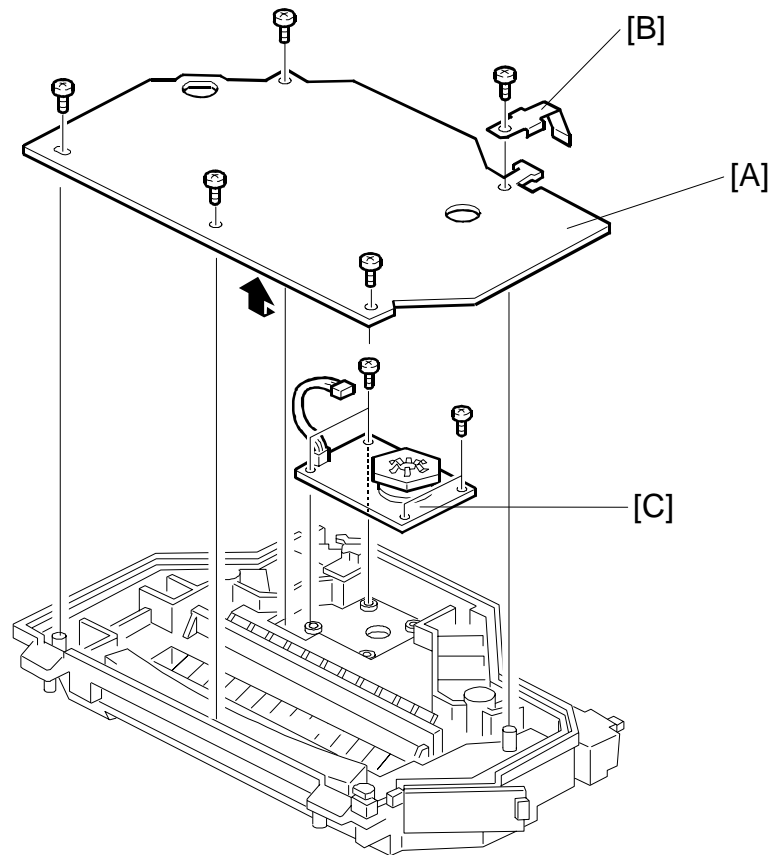

G031R504.WMF

**NOTE:** When doing the following steps, take care not to damage the mirror surface with the tip of the screwdriver.

1. Remove the top cover. (Refer to Exterior Cover Removal, section 6.1.1.)
2. Remove the laser unit top cover [A] (5 screws and 1 grounding plate [B]).
3. Replace the polygonal mirror motor [C] (4 screws and 1 connector).

Replacement  
Adjustment

## 6.5.5 LD UNIT/POLYGONAL MIRROR MOTOR REPLACEMENT

### *Stinger - P4*

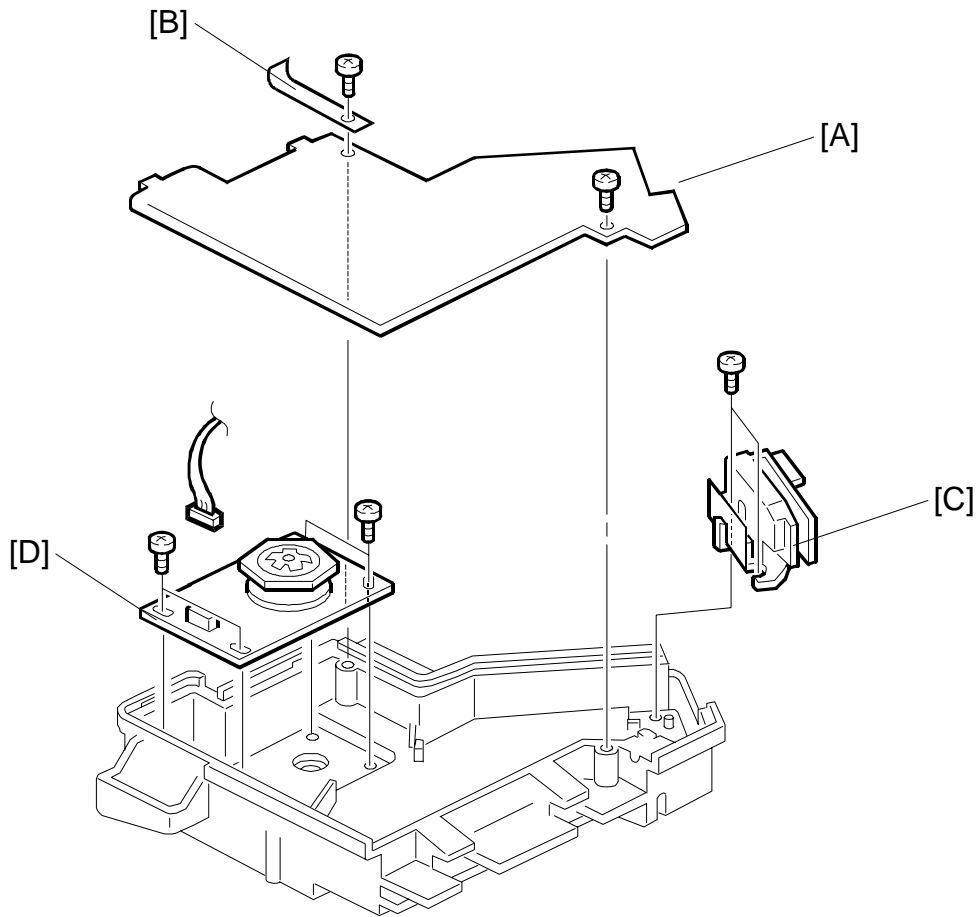

G031R506.WMF

#### *LD Unit*

1. Remove the top cover. (Refer to Exterior Cover Removal, section 6.1.1.)
2. Remove the laser unit top cover [A] (2 screws and 1 grounding plate [B]).
3. Replace the LD unit [C] (2 screws and 1 connector).

**NOTE:** Do not touch VR101 on the LD unit, because it is adjusted in the factory before shipment.

#### *Polygonal Mirror Motor*

**NOTE:** When doing the following steps, take care not to damage the mirror surface with the tip of the screwdriver.

1. Remove the top cover. (Refer to Exterior Cover Removal, section 6.1.1.)
2. Remove the laser unit top cover [A] (2 screws and 1 grounding plate [B]).
3. Replace the polygonal mirror motor [D] (4 screws and 1 connector).

## 6.6 OTHERS

### 6.6.1 TONER NEAR-END SENSOR REPLACEMENT

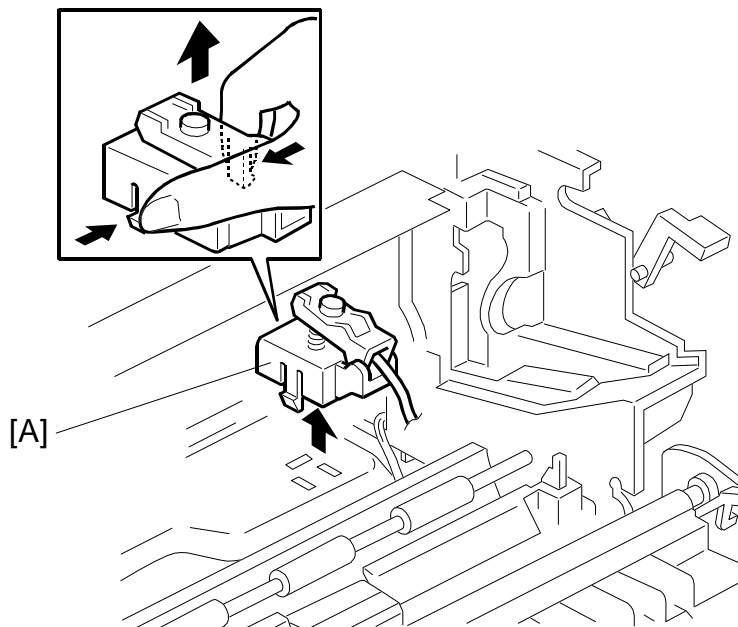

G031R535.WMF

1. Remove the control board cover. (Refer to Control Board Cover Removal, section 6.1.3.)
2. Remove the toner cassette.
3. Replace the toner near-end sensor [A], as shown (1 connector on the engine control board).

Replacement  
Adjustment

## 6.6.2 MAIN MOTOR/GEAR BOX REMOVAL

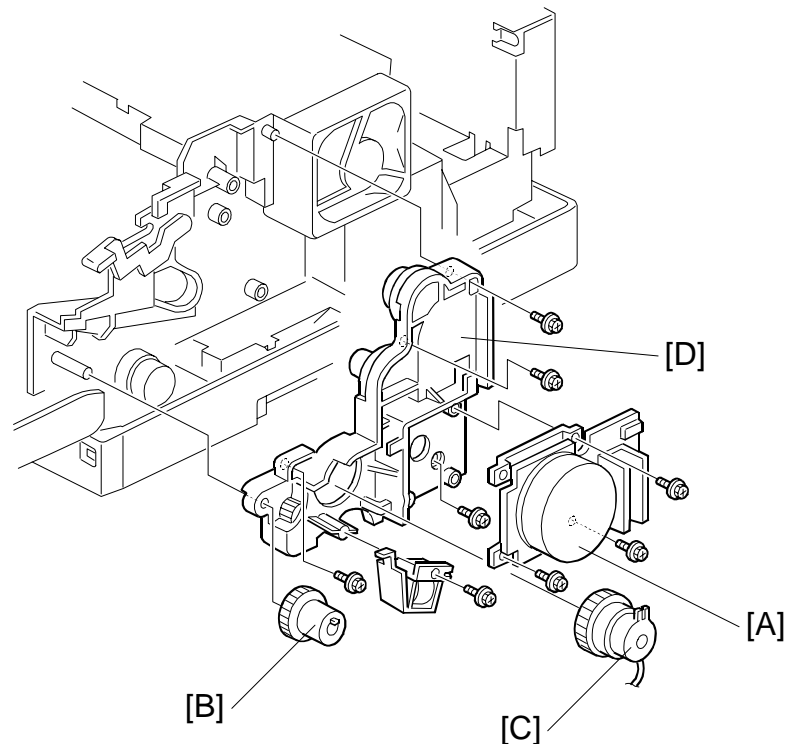

G031R536.WMF

### ***Main Motor***

1. Remove the right cover. (Refer to Exterior Cover Removal, section 6.1.1.)
2. Remove the main motor [A] (3 screws and 1 connector).

### ***Gear Box***

1. Remove the control board cover. (Refer to Control Board Cover Removal, section 6.1.3.)
2. Remove the by-pass feed clutch [B]. (Refer to By-pass Feed Roller Replacement, section 6.4.2.)
3. Remove the main motor. (Refer to Main Motor Removal.)
4. Remove the registration clutch [C] (1 snap ring).
5. Remove the gear box [D] (5 screws).

### 6.6.3 ENGINE CONTROL BOARD REPLACEMENT

**⚠ CAUTION**

Before replacing the engine control board, do the following:  
Make sure that there is no print data in the printer buffer (the Data In LED must not be lit or blinking).  
If there is some data in the buffer, wait until all data has been printed.

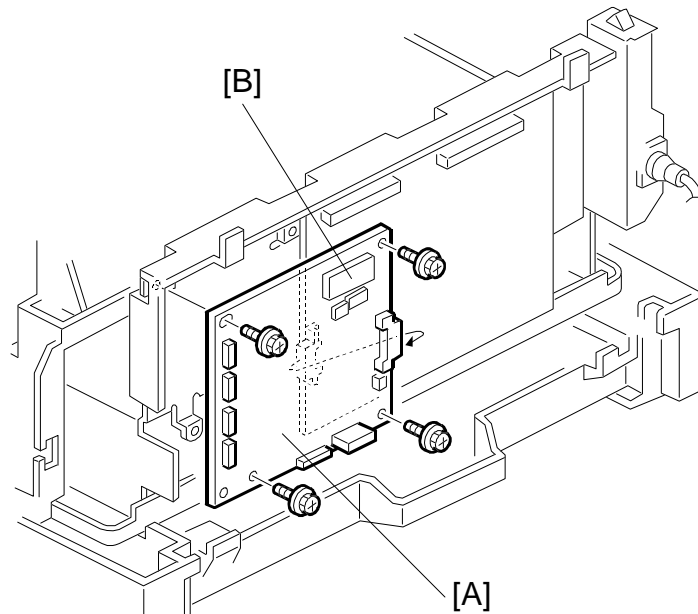

G031R537.WMF

**NOTE:** Before replacing the engine board, print out the print log (see “Service Program Mode - Print Log” in section 4).

1. Remove the control board cover. (Refer to Control Board Cover Removal, section 6.1.3.)
2. Replace the engine control board [A]. (4 screws and all connectors).
3. Take the EEPROM (IC5) [B] off the old board, and put it on the new board.



## 6.6.4 PRINTER CONTROL BOARD REPLACEMENT

### **⚠ CAUTION**

Before replacing the engine control board, do the following:

Make sure that there is no print data in the printer buffer (the Data In LED must not be lit or blinking).

If there is some data in the buffer, wait until all data has been printed.

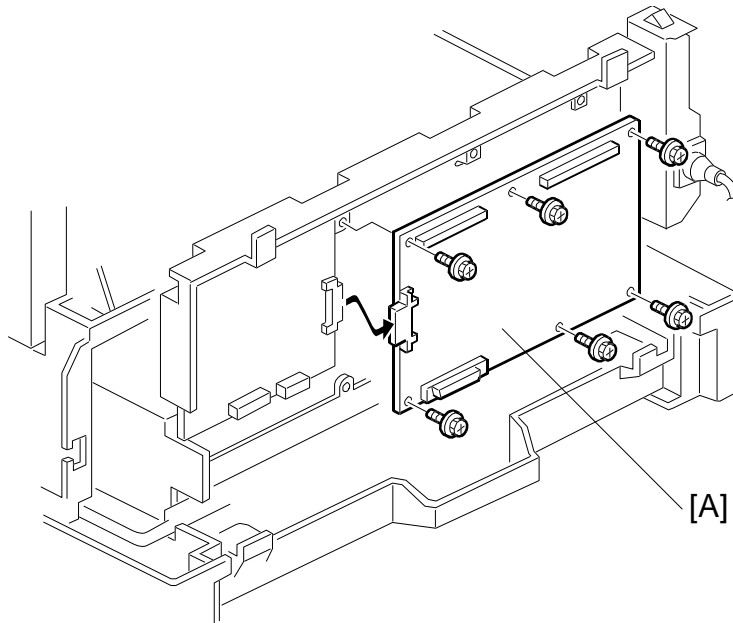

G031R538.WMF

**NOTE:** Before replacing the controller board, print out the configuration page (User Menu – List Print – Config Page) and the print log (see “Service Program Mode - Print Log” in section 4).

1. Remove the control board cover. (Refer to Control Board Cover Removal, section 6.1.3.)
2. Replace the printer control board [A] (6 screws and all connectors).
3. Take the NVRAM off the old board, and put it in the socket on the new board.

## 6.6.5 HIGH VOLTAGE SUPPLY BOARD

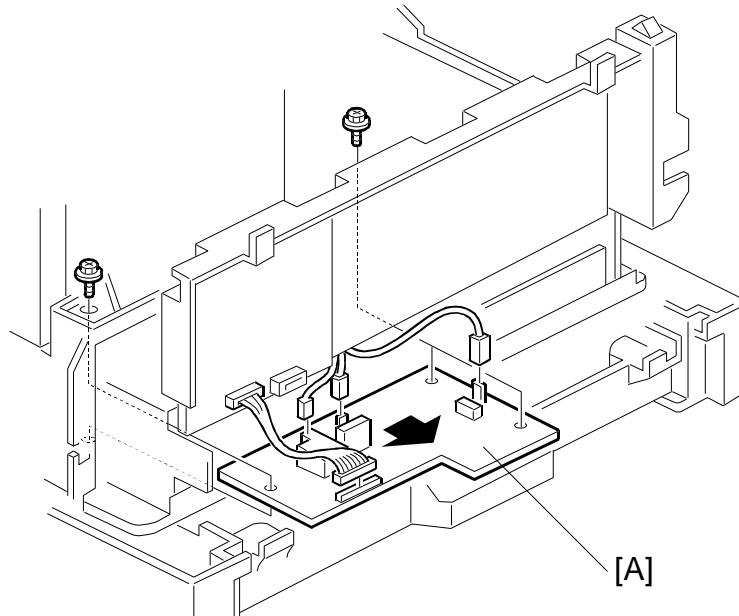

G031R539.WMF

1. Remove the control board cover. (Refer to Control Board Cover Removal, section 6.1.3.)
2. Remove the LD unit. (Refer to LD Unit/Laser Synchronization Detector Replacement section 6.5.3 for Stinger-P3, or LD Unit/Polygonal Mirror Motor Replacement section 6.5.5. for Stinger-P4.)
3. Remove the engine control board. (Refer to Engine Control Board Replacement, section 6.6.3.)
4. Remove the high voltage supply board [A] (3 screws and 4 connectors).  
**NOTE:** Do not touch the variable resistors on the high voltage supply board, because they are adjusted in the factory before shipment.

 Replacement  
Adjustment

## 6.6.6 POWER SUPPLY UNIT REPLACEMENT

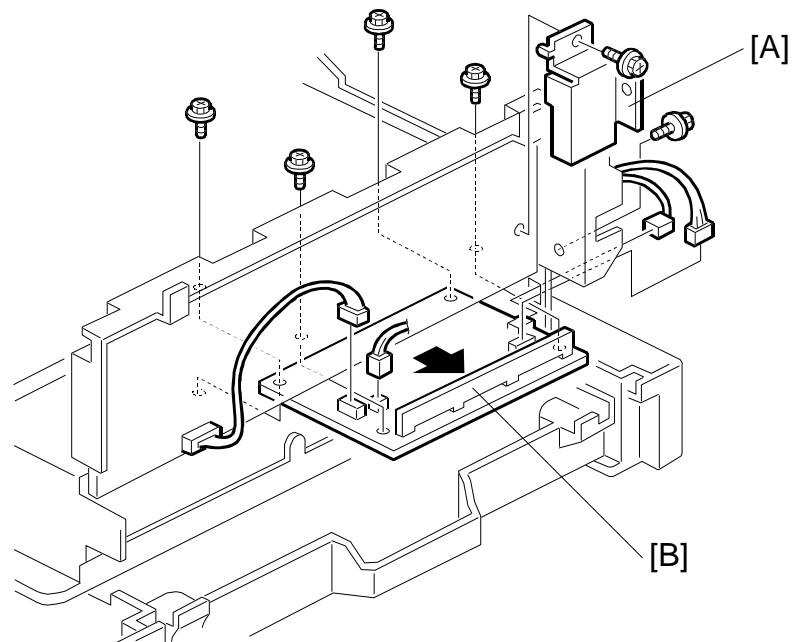

G031R540.WMF

1. Remove the control board cover. (Refer to Control Board Cover Removal, section 6.1.3.)
2. Remove the LD unit. (Refer to LD Unit/Laser Synchronization Detector Replacement section 6.5.3 for Stinger-P3, or LD Unit/Polygonal Mirror Motor Replacement section 6.5.5. for Stinger-P4.)
3. Remove the printer control board. (Refer to Printer Control Board Replacement, section 6.6.4.)
4. Remove the bracket [A] (2 screws).
5. Remove the power supply unit [B] (4 screws and 4 connectors).

## 6.7 PRINT REGISTRATION ADJUSTMENT

Perform the following adjustment(s) after replacing any of the following parts:

- Rollers and gears
- Polygon mirror motor
- Paper feed unit
- Paper side fence
- Memory All Clear

For more details about accessing service modes, refer to section 4.

**NOTE:** 1) Use the frame on the service mode print log for the following procedures.  
 2) Place A4 or LT paper in all paper feed trays, since the print log is available only in these sizes.  
 3) To change the paper feed tray for printing the print log, change the 'output tray' setting inside the print log mode of the service program menu to the desired paper feed tray.

1. Turn on the machine while pressing the "On line" key and "Escape" key together to enter the service mode. Use the "arrow" key until "PRINT LOG" appears.
2. Print out the print log from the desired paper feed tray and check the margin at all four sides. Adjust the registration to meet the specification given below.

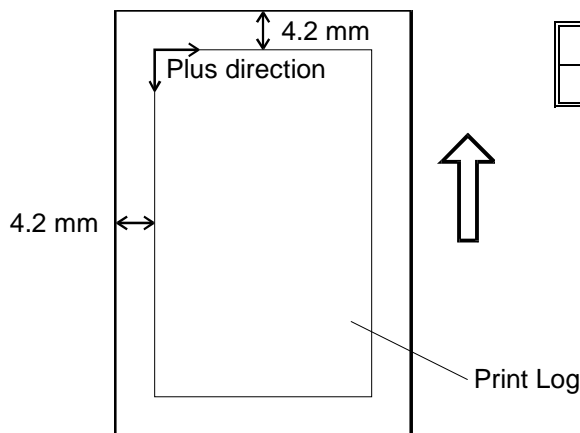

G031R546.WMF

### - PRINT MARGIN SPECIFICATION -

	Specification
All paper feed trays	4.2 mm

Replacement  
Adjustment

3. Check the margin at the leading and trailing edges of the frame. If out of specification, adjust with Sub Scan in the service program mode. This will adjust the paper feed timing, and will affect all paper feed trays. If the setting is moved in the **plus** direction, the top margin will be bigger.
4. Check the margin at both sides of the frame. If out of specification, adjust with Main Scan in the service program mode. This will adjust the laser start timing, and is individually adjusted for each paper feed tray. If the setting is moved in the **plus** direction, the right margin will be bigger.

## 7. TROUBLESHOOTING

### 7.1 OPERATOR ERRORS

Function	Error Message
Front Cover Open	Close Front Cover
Paper Size Error	Check Paper Size Tray XX
Paper Misfeed	Remove Misfeed Front Cover & Tray Remove Misfeed Open Front Cover
Toner Cartridge Installation Error	Replace Toner Cartridge
Fusing Unit Installation Error	Replacing Fusing Unit
Maintenance Kit Replacement Time	Replace Maintenance Kit
Tray Installation Error	Install Tray XX
Paper End	Tray XX: Add paper
Paper Tray Error	Load Tray XX: {paper size} Load By-pass Tray XX: {paper size}
Memory Overflow	Memory Overflow
Print Overrun	Print Overrun
Hard Disk Error	Error SC 2600
Network Interface Board Error	Error SC 2700
RS232C Board Error	Error SC 2900
Memory Unit (SIMM) Error	Error SC 3100
Right Optional Board Error	Error SC 3200
Left Optional Board Error (Stinger-P3 only)	Error SC 3201

#### ***Front Cover Open***

Message:

Close Front Cover

Definition:

The front cover is open.

Reset Method:

Close the front cover.

#### ***Paper Size Error***

Message:

Check Paper Size Tray XX

Definition:

The paper size setting of the tray differs from the actual paper size in the tray.

Reset Method:

- Pull out the paper tray and check the paper size setting then put the tray back.
- Press "Enter" and load the correct size of paper into the tray.

***Paper Misfeed***

Message:

- Remove Misfeed Front Cover & Tray
- Remove Misfeed Open Front Cover

Definition:

There is a misfeed in the printer.

Reset Method:

Remove the misfed paper.

***Toner Cartridge Installation Error***

Message:

Replace Toner Cartridge

Definition:

The toner cartridge is not installed correctly or toner has almost run out.

Reset Method:

- Set the toner cartridge correctly.
- If the image density gets too light, replace the toner cartridge.

**NOTE:** This machine only has a toner near-end sensor. There is no toner end sensor.

***Fusing Unit Installation Error***

Message:

Replacing Fusing Unit

Definition:

The fusing unit is not installed correctly.

Reset Method:

Set the fusing unit correctly.

***Maintenance Kit Replacing Time***

Message:

Replace Maintenance Kit

Definition:

It is time to replace the parts in the maintenance kit.

Reset Method:

- Stinger - P3: Replace the maintenance kit.
- Stinger - P4: Replace the maintenance kit, then do the User Tools – Maintenance – PM Clear procedure.

**Tray Installation Error**

Message:

Install Tray XX

Definition:

Tray XX is not installed correctly.

Reset Method:

Set the tray correctly.

**Paper End**

Message:

Tray XX: Add Paper

Definition:

Paper has run out in tray XX.

Reset Method:

Load paper.

**Paper Tray Error**

Message:

- Load Tray XX: {paper size}
- Load Bypass Tray: {paper size}

Definition:

- Tray XX (or the by-pass tray) is empty.
- The actual size of paper loaded in tray XX (or the by-pass tray) does not match the size for which the page was created.

Reset Method:

Load paper of the correct size in the specified feed direction into tray XX (or the by-pass tray), and print automatically. If not, check that the paper size setting in the tray is correct.

- NOTE:** 1) When “Auto Select” is specified for the paper source using the printer driver, this message might appear when there is paper of the correct size but in the different feed direction in any of the trays.
- 2) The page is printed on the incorrect paper size in tray XX (or the by-pass tray) in the following cases.
- a) If you press “Enter” without loading the correct paper.
  - b) If a specified period of time has passed with the Auto Continue feature on. (Auto Continue does not work if this error exists.) If that happens, you cannot continue printing if there is a paper size error. You should take one of the following actions to clear this error.
    - Press “Enter”.
    - Open and close any of the trays.

***Memory Overflow***

Message:

Memory Overflow

Definition:

There is not enough memory to print the data.

Reset Method:

If the "Auto Continue" feature is on or when the "Enter" key is pressed, the data in the memory is printed out. To clear this message, change the print resolution from 1,200 dpi to 600 dpi or 300 dpi, and try printing again. If the job cannot be printed completely, you should increase the memory capacity.

***Print Overrun***

Message:

Print Overrun

Definition:

The data sent to the printer was too complex.

Reset Method:

Press "Enter" to print out the data sent to the printer. If you do not want to lose any of the transferred data, set the "Page Protect" feature to "On" before printing the job. If you cannot clear this message, simplify the print job.

**NOTE:** Make sure to return the "Page Protect" feature to "Off" after the print job.

With the "Page Protect" feature "On", printer performance might be reduced.

***Hard Disk Error***

Message:

Error SC\_2600

Definition:

Error in the optional HDD.

Reset Method:

Remove the HDD from the printer and turn the printer's main switch off and on. Then try to do the print job again.

***Network Interface Board Error***

Message:

Error SC\_2700

Definition:

Error in the optional network interface board.

Reset Method:

Remove the network interface board from the printer and turn the printer's main switch off and on. Then try to do the print job again.



***RS232C Board Error***

Message:

Error SC\_2900

Definition:

Error in the optional RS232C board.

Reset Method:

Remove the RS232C board from the printer and turn the printer's main switch off and on. Then try to do the print job again.

***Memory Unit (SIMM) Error***

Message:

Error SC\_3100

Definition:

Error in the optional memory unit (SIMM).

Reset Method:

Remove the memory unit from the printer and turn the printer's main switch off and on. Then try to do the print job again.

**NOTE:** If you remove the memory unit, you might not be able to print a job that contains large or complex data.

***Right Optional Board Error***

Message:

Error SC\_3200

Definition:

Error in the right optional board.

Reset Method:

Remove the right optional board from the printer and turn the printer's main switch off and on. Then try to do the print job again.

***Left Optional Board Error***

Message:

Error SC\_3201

Definition:

Error in the left optional board.

Reset Method:

Remove the left optional board from the printer and turn the printer's main switch off and on. Then try to do the print job again.

## 7.2 PRINTER ENGINE SC CODES

SC No.	Function
302	High Voltage Power Supply Error
320	Polygon Mirror Motor Error
322	Laser Synchronization Error
500	Main Motor Error
542	Fusing Temperature Warm-up Error
543	Fusing High Temperature Error
544	Fusing Low Temperature Error
998	Fusing Unit Mismatch
999	Communication Error

**NOTE:** To clear SC codes from SC542 to SC544, repair the machine then use Fuser Error Clear in service mode (turn on the machine while pressing 'On Line' and 'Escape' to access this). Other SC codes are automatically cleared after the machine is repaired.

### ***SC302: High Voltage Power Supply Error***

Definition:

- A charge roller current leak signal is detected.
- A transfer roller current leak signal is detected.
- A development bias leak signal is detected.

Possible Causes:

- Charge roller damaged.
- Transfer roller damaged.
- Discharge brush grounding problem
- High voltage supply board defective
- Poor PSU connection

### ***SC320: Polygon Mirror Motor Error***

Definition:

The polygon mirror motor does not reach its operating speed within 10 seconds after the polygon mirror motor on signal, or the lock signal is not detected for more than 10 seconds continuously during operation.

Possible Causes:

- Polygon mirror motor defective
- Poor connection between the polygon mirror motor driver and the engine control board
- Engine control board defective

**SC322: Laser Synchronization Error**

## Definition:

The laser synchronization signal cannot be detected by the main scan synchronization detector board for more than 4 consecutive 100 ms intervals.

## Possible Causes:

- Laser synchronization detector out of position
- Laser synchronization detector defective
- Engine control board defective

**SC500: Main Motor Error**

## Definition:

A main motor lock signal is detected for more than 1 second or the lock signal is not detected for more than 500 ms during rotation.

## Possible Causes:

- Too much load on the drive mechanism
- Main motor defective

**SC542: Fusing Temperature Warm-up Error**

## Definition:

The fusing temperature does not reach 80°C within 60 seconds after the main switch is turned on or after the covers have been closed. Or, during warming-up, the fusing temperature does not change by at least 3°C within 5 seconds.

## Possible Causes:

- Fusing thermistor defective or out of position
- Fusing lamp open
- Fusing thermofuse open
- Power supply unit defective
- Poor fusing unit connection
- Engine control board defective

**SC543: Fusing High Temperature Error**

## Definition:

A fusing temperature of over 230°C is detected for 1 second by the fusing thermistor.

## Possible Causes

- Fusing thermistor defective
- Power supply unit defective

***SC544: Fusing Low Temperature Error***

Definition:

A fusing temperature of lower than 100°C is detected for 1 second by the fusing thermistor (this error does not apply when the machine is in energy saver mode).

Possible causes

- Fusing thermistor defective
- Power supply unit defective

***SC998: Fusing Unit Mismatch***

Definition:

The fusing unit for a different area is installed in the machine.

Possible causes

- Wrong fusing unit

***SC999: Communication Error***

Definition:

Communication error between engine and control board.

Possible causes

- Command error or parity error between engine and control board.

## 7.3 DIAGNOSTIC ERROR CODES

### 7.3.1 DIAGNOSTIC ERROR CODE TABLE

The diagnostic error codes are shown in the following table.

#### *Power-up Diagnostic Mode*

Device Name	Device Code	Error Code	Description	Possible Cause
VR4300 (CPU) Timer	01	SC2102	CPU (VR4300) timer error	• Printer Control Board defective
Code ROM	02	SC2100	Flash ROM check sum error	• Printer Control Board defective
Resident DRAM	03	SC2101	Resident DRAM check error	• Printer Control Board defective
VR4300 Exception	04	SC2102	Exception interrupt check error	• Printer Control Board defective
VR4300 Cache	05	SC2102	Data cache or instruction cache check error	• Printer Control Board defective
VR4300 FPU	06	SC2102	Floating point operation error	• Printer Control Board defective
ASIC Timer	07	SC2104	ASIC timer error	• Printer Control Board defective
NVRAM	08	SC2105	NVRAM check error	• Printer Control Board defective
ASIC P1284 (parallel port)	09	--	Not tested during power-up diagnostics	
ASIC Engine I/F	0A	SC2500	Engine interface check error	• Printer Control Board defective
Font ROM	0B	SC2103	Font ROM CRC check error	• Printer Control Board defective
ASIC PVDMA	0D	SC2104	PVDMA operation error in the ASIC	• Printer Control Board defective
Optional DIMM	10	SC2800	DIMM check error	• Remove the DIMM
Optional SIMM	11	SC3100	SIMM check error	• Optional SIMM defective
HDD	12	SC2600	HDD check error	• Optional HDD defective
NIB	13	SC2700	NIB check error	• Optional NIB defective
RS232C Test	14	SC2900	RS232C test error	• Optional RS232C defective
Option0	15	SC3200	Unidentified or unsupported device in the right option slot	• Optional device in the right option slot defective
Option1 (Only Stinger - P3)	15	SC3201	Unidentified or unsupported device in the left option slot	• Optional device in the left option slot defective

**Power-up and Detailed Diagnostic Modes – Program Execution Errors**

<b>Error Code</b>	<b>Description</b>	<b>Possible Cause</b>
**A1	Accessing error for prohibited address	• Printer Control Board defective
**A2	Unmatched load or fetch address for TLB	
**A3	Unmatched store address for TLB	
**A4	Load or fetch address error	
**A5	Store address error	
**A6	Bus error for fetch	
**A7	Bus error for load or store	
**A8	System call exception	
**A9	Break point exception	
**AA	Fetch unsupported command	
**AB	Co-processor exception	
**AC	Overflow exception	
**AD	Trap command exception	
**AF	Floating point operation exception	
**B7	Watch exception	
**B8	Data access or fetch with vertical address	
**E0	Interrupt 0 exception	
**E1	Interrupt 1 exception	
**E2	Interrupt 2 exception	
**E3	Interrupt 3 exception	
**E4	Interrupt 4 exception	
**E5	Interrupt 5 exception	

The above “\*\*” means the device code for which the diagnostic program error occurred during its device test. For details of the device codes, refer to the ‘Device Code’ column of the “Power-up Diagnostic Mode” table.

**Detailed Diagnostic Mode – Other Errors**

Device.	Code	Description	Possible Cause
VR4300 Timer	0101	Clock frequency error	<ul style="list-style-type: none"> <li>• Printer Control Board defective</li> </ul>
	0102	Interrupt error	
	0103	Exception interrupt error	
	0104	Interrupt masking error	

Device.	Code	Description	Possible Cause
Code ROM	0201	Sum check error	<ul style="list-style-type: none"> <li>• Printer Control Board defective</li> </ul>

Device.	Code	Description	Possible Cause
Resident DRAM	0301	Write and read check error	<ul style="list-style-type: none"> <li>• Printer Control Board defective</li> </ul>

Device.	Code	Description	Possible Cause
VR4300 Exception	0401	Error during the address error check with load or fetch instructions	<ul style="list-style-type: none"> <li>• Printer Control Board defective</li> </ul>
	0402	Error during the address error check with storing instructions	
	0403	Error during the bus error check with jump instructions	
	0404	Error during the bus error check with load or storing instructions	
	0405	Error during the system call check with SYSCALL instructions	
	0406	Error during the break point check with BREAK instructions	
	0407	Error during the unsupported instructions check of the VR4300	
	0408	Coprocessor check error	
	0409	Overflow check error	
	040A	Error during the trap check with the TRAP instructions	
	040B	Floating point calculation check error	
	040C	Error during the watch-LO register check	
	040D	VR4300 TLB register check error	

Device.	Code	Description	Possible Cause
VR4300 Cache	0501	Instruction cache size error	<ul style="list-style-type: none"> <li>• Printer Control Board defective</li> </ul>
	0502	Instruction cache hit error	
	0503	Instruction cache write back error	
	0504	Instruction cache clear error	
	0511	Data cache size error	
	0512	Data cache hit error	
	0513	Data cache write back error	
	0514	Data cache write back clear error	
	0515	Data cache clear error	

Trouble-shooting

Device.	Code	Description	Possible Cause
VR4300 FPU	0601	Addition error during floating point operations with low accuracy mode	<ul style="list-style-type: none"> <li>• Printer Control Board defective</li> </ul>
	0602	Subtraction error during floating point operations with low accuracy mode	
	0603	Division error during floating point operations with low accuracy mode	
	0604	Multiplication error during floating point operations with low accuracy mode	
	0605	Addition error during floating point operations with high accuracy mode	
	0606	Subtraction error during floating point operations with high accuracy mode	
	0607	Division error during floating point operations with high accuracy mode	
	0608	Multiplication error during floating point operations with high accuracy mode	

Device.	Code	Description	Possible Cause
ASIC Timer	0701	ASIC interrupt request error	<ul style="list-style-type: none"> <li>• Printer Control Board defective</li> </ul>
	0702	VR4300 interrupt request error	
	0703	Interrupt check error	
	0704	Interrupt mask error	
	0705	Timer frequency error	

Device.	Code	Description	Possible Cause
NVRAM	0802	NVRAM verification check error	<ul style="list-style-type: none"> <li>• Printer Control Board defective</li> </ul>
	0804	Write error	

Device.	Code	Description	Possible Cause
ASIC P1284	0901	Timeout error	<ul style="list-style-type: none"> <li>• Printer Control Board defective</li> </ul>
	0902	Interrupt request error of the ASIC when the STROBE signal goes low	
	0903	Interrupt request error of the VR4300 when the STROBE signal goes low	
	0904	Interrupt start error of the VR4300 when the STROBE signal goes low	
	0905	Interrupt masking error when the STROBE signal goes low	
	0906	Interrupt request error of the ASIC when the STROBE signal goes high	
	0907	Interrupt request error of the VR4300 when the STROBE signal goes high	
	0908	Interrupt start error of the VR4300 when the STROBE signal goes high	
	0909	Interrupt masking error when the STROBE signal goes high	
	090A	Interrupt request error of the ASIC when the INIT signal goes low	



Device.	Code	Description	Possible Cause
ASIC P1284	090B	Interrupt request error of the VR4300 when the INIT signal goes low	<ul style="list-style-type: none"> <li>Printer Control Board defective</li> </ul>
	090C	Interrupt start error of the VR4300 when the INIT signal goes low	
	090D	Interrupt masking error when the INIT signal goes low	
	090E	Interrupt request error of the ASIC when the INIT signal goes high	
	090F	Interrupt request error of the VR4300 when the INIT signal goes high	
	0910	Interrupt start error of the VR4300 when the INIT signal goes high	
	0911	Interrupt masking error when the INIT signal goes high	
	0912	Interrupt request error of the ASIC when the SELECT signal goes low	
	0913	Interrupt request error of the VR4300 when the SELECT signal goes low	
	0914	Interrupt start error of the VR4300 when the SELECT signal goes low	
	0915	Interrupt masking error when the SELECT signal goes low	
	0916	Interrupt request error of the ASIC when the SELECT signal goes high	
	0917	Interrupt request error of the VR4300 when the SELECT signal goes high	
	0918	Interrupt start error of the VR4300 when the SELECT signal goes high	
	0919	Interrupt masking error when the SELECT signal goes high	
	091A	Interrupt request error of the ASIC when the FEED signal goes low	
	091B	Interrupt request error of the VR4300 when the FEED signal goes low	
	091C	Interrupt start error of the VR4300 when the FEED signal goes low	
	091D	Interrupt masking error when the FEED signal goes low	
	091E	Interrupt request error of the ASIC when the FEED signal goes high	
	091F	Interrupt request error of the VR4300 when the FEED signal goes high	
	0920	Interrupt start error of the VR4300 when the FEED signal goes high	
	0921	Interrupt masking error when the FEED signal goes high	
	0922	Loopback data error	
	0923	Interrupt request error of the ASIC in DMA mode	
0924	Interrupt request error of the VR4300 in DMA mode		
0925	Interrupt start error of the VR4300 in DMA mode		

Device.	Code	Description	Possible Cause
ASIC P1284	0926	Interrupt masking error in DMA mode	• Printer Control Board defective
	0927	Loopback data error in DMA mode	
	0928	Interrupt request error of the ASIC in ECP DMA mode	
	0929	Interrupt request error of the VR4300 in ECP DMA mode	
	092A	Interrupt start error of the VR4300 in ECP DMA mode	
	092B	Interrupt masking error in ECP DMA mode	
	092C	Loopback data error in ECP DMA mode	

Device.	Code	Description	Possible Cause
Engine I/F	0A01	Transmission timeout	• Printer Control Board defective
	0A02	Reception timeout	
	0A03	Reception parity error	
	0A04	Data error	
	0A05	Interrupt request error of the ASIC during command reception	
	0A06	Interrupt request error of the VR4300 during command reception	
	0A07	Interrupt start error of the VR4300 during command reception	
	0A08	Interrupt masking error during command reception	

Device.	Code	Description	Possible Cause
Font ROM	0B01	Font ROM CRC check error	• Printer Control Board defective

Device.	Code	Description	Possible Cause
ASIC PVDMA	0D01	Interrupt request error of the ASIC in PVDMA mode	• Printer Control Board defective
	0D02	Interrupt request error of the VR4300 in PVDMA mode	
	0D03	Interrupt start error of the VR4300 in PVDMA mode	
	0D04	Interrupt masking error in PVDMA mode	
	0D05	PVDMA mode timeout	
	0D06	PVDMA read bus error	
	0D07	PVDMA write bus error	
	0D08	FILL operation error	
	0D09	MOVE operation error	
	0D0A	HALF operation error	
	0D0B	QUART operation error	
	0D0C	K3 operation error	
	0D0D	K3 double operation error	

Device.	Code	Description	Possible Cause
Optional DIMM	1010	Formatting error	<ul style="list-style-type: none"> <li>• Optional DIMM defective</li> <li>• Printer Control Board defective</li> </ul>
	1011	Version error	
	1012	NVRAM version error	

Device.	Code	Description	Possible Cause
Optional SIMM	1102	SIMM size error: Unsupported SIMM size	<ul style="list-style-type: none"> <li>• Optional SIMM defective</li> <li>• Printer Control Board defective</li> </ul>
	1103	8MB SIMM check error	
	1104	16MB SIMM check error	
	1105	32MB SIMM check error	

Device.	Code	Description	Possible Cause
HDD	1201	The CPU did not receive the device ready signal after the specified time.	<ul style="list-style-type: none"> <li>• Optional HDD defective</li> <li>• Printer Control Board defective</li> </ul>
	1202	Interrupt request error of the ASIC in HDD mode	
	1203	Interrupt request error of the VR4300 in HDD mode	
	1204	Interrupt start error of the VR4300 in HDD mode	
	1205	HDD interrupt masking error	
	1206	HDD register error	
	1207	HDD buffer RAM error	
	1208	HDD ECC error	
	1209	HDD ROM/RAM error	
	120A	HDD diagnostic command error	
	120B	HDD data transmission error	
120C	HDD read verification error		

Device.	Code	Description	Possible Cause
NIB	1301	Initialization error	<ul style="list-style-type: none"> <li>• Optional NIB defective</li> <li>• Printer Control Board defective</li> </ul>
	1302	Command timeout error	
	1303	Command reception interrupt request error of the ASIC in NIB mode	
	1304	Command reception interrupt request error of the VR4300 in NIB mode	
	1305	Command reception interrupt start error in NIB mode	
	1306	Command reception interrupt masking error in NIB mode	
	1307	NIB command error	
	1308	NIB buffer full error	

Trouble-shooting

Device.	Code	Description	Possible Cause
RS232C	1401	Initialization error	Optional RS232C defective Printer Control Board defective
	1402	Empty interrupt request error of the ASIC in RS232C mode	
	1403	Empty interrupt request error of the VR4300 in RS232C mode	
	1404	Empty interrupt start error of the VR4300 in RS232C mode	
	1405	Empty interrupt masking error of the in RS232C mode	
	1406	DSR error	
	1407	Command timeout error	
	1408	Loopback error	

Device.	Code	Description	Possible Cause
Option Error	1501	Unidentified or unsupported device in the right option slot	Optional device in the right option slot defective
	1502	Unidentified or unsupported device in the left option slot (only Stinger – P3)	Optional device in the left option slot defective

## 7.4 ELECTRICAL COMPONENT DEFECTS

### 7.4.1 SENSORS

Component (Symbol)	CN	Condition	Symptom
Fusing Exit (S1)	6-8 (ECB)	Open	A paper jam at the fusing unit whenever a print is made.
		Shorted	The Paper Jam message appears even if there is no paper.
Tray Paper End (S2)	4-1 (ECB)	Open	The Paper End message appears even if paper is placed in the paper tray.
		Shorted	The Paper End message does not appear even if there is no paper in the paper tray.
Tray Paper Near-end (S3)	4-4 (ECB)	Open	The Paper Near End message does not appear on the PC even if the paper tray is almost empty.
		Shorted	The Paper Near End message appears on the PC even if enough paper is placed in the paper tray.
By-pass Tray Paper Set (S4)	3-5 (ECB)	Open	When selecting the by-pass tray, the Paper End message does not appear even if there is no paper in the by-pass tray.
		Shorted	When selecting the by-pass tray, the Paper End message appears even if there is paper in the by-pass tray.
Registration (S5)	3-2 (ECB)	Open	A paper jam at the registration roller when a print is made.
		Shorted	The Paper Jam message appears even if there is no jam.
Toner Near-end (S6)	5-2 (ECB)	Open	Toner is not added, even if there is not enough toner in the toner supply unit.
		Shorted	Toner is added, even if there is enough toner in the toner supply unit.

### 7.4.2 SWITCHES

Component (Symbol)	CN	Condition	Symptom
Main (SW1)	101-1,2 (PSU)	Open	The machine does not turn on.
		Shorted	The machine does not turn off.
Front Cover Safety (SW2)	103-1,2 (PSU)	Open	The Cover Open message is displayed even if the front cover is closed.
		Shorted	The Cover Open message is not displayed even if the front cover is open.
Tray Paper Size (SW3)	4-5,6,8 (ECB)	Open	The CPU cannot detect the proper paper size, and misfeeds may occur when a print is made.
		Shorted	

Trouble-shooting

### 7.4.3 FUSES

Fuse	Rating		Symptom when turning on the main switch
	115 V	220 ~ 240 V	
<b>Power Supply Board</b>			
FU1	5 A/125 V	3.15 A/250 V	No response.
FU2	15 A/250 V	6.3 A/250 V	After turning on the main switch, SC542 is displayed.
FU3	5 A/125 V	5 A/250 V	No response.

# **APPENDIX**

## **Downloading Controller Firmware for Stinger - P3/P4**

# 1. DOWNLOADING CONTROLLER FIRMWARE

## 1.1 OVERVIEW

This appendix describes the ways that the controller firmware can be upgraded. There are three basic methods.

### 1.1.1 IC CARD (FLASH CARD)

First, new firmware has to be stored in the IC card. There are two ways to do this.

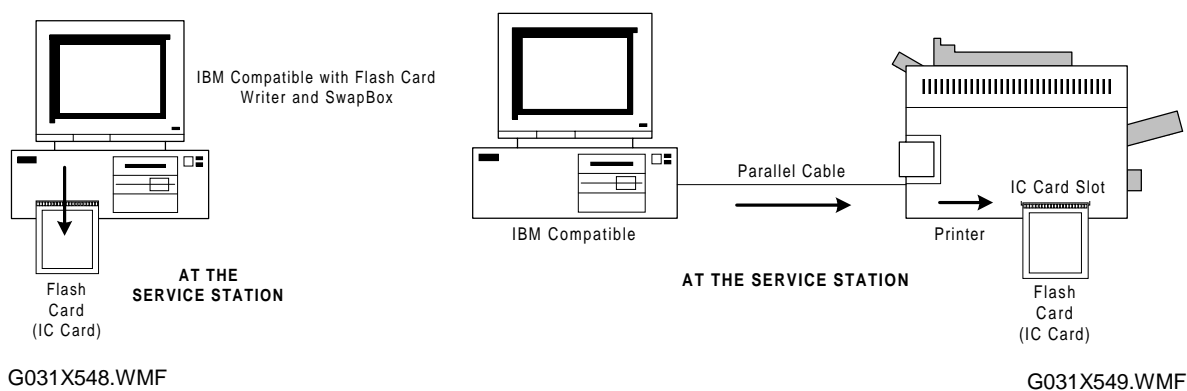

- Using a flash card writer and SwapBox
- Copying to an IC card plugged into a Stinger P3 or P4 printer via a parallel cable, using either the DOS copy /b command or the Stinger downloading utility.

Then, the IC card is taken to the customer's premises, and downloaded using a service mode.

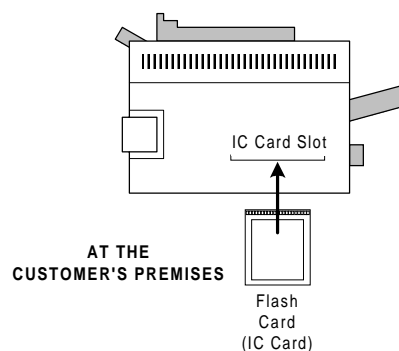

G031X550.WMF

The IC card is available as a service tool.

### 1.1.2 PC, VIA PARALLEL PORT

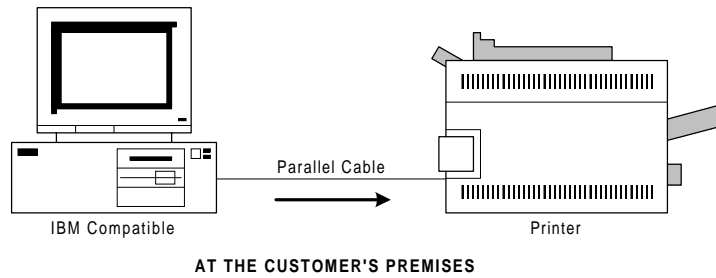

G031X551.WMF

At the customer site, new firmware can be downloaded to the printer from a PC via a parallel cable using either the DOS copy /b command or the Stinger downloading utility.

### 1.1.3 DIMM

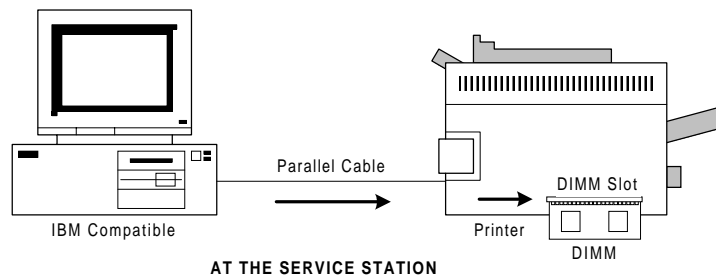

G031X552.WMF

First, the new firmware must be stored on an 8 MB DIMM. This is done by copying the firmware from a PC to a DIMM plugged into a Stinger P3 or P4 printer via a parallel cable, using either the DOS copy /b command or the Stinger downloading utility.

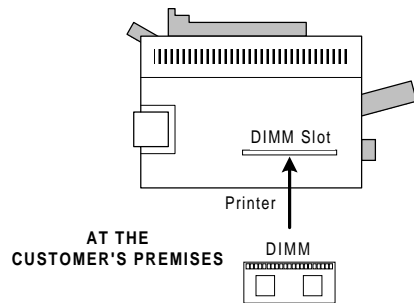

G031X553.WMF

Then, the IC card is taken to the customer's premises, and downloaded using a service mode.

The DIMM card is available as a service tool.



### **1.1.4 RELEASING NEW CONTROLLER FIRMWARE**

Two controller firmware files will be released (e.g. P3card.rom and P4card.rom). This firmware can be copied to an IC card using the Swapbox utility.

To download firmware from a PC to the printer, a byte-swapping operation must be performed on the released firmware. To do this, use the Byte Swap button of the SSU (Stinger Service Utility) program. This creates new files, e.g., P3carddwn.rom and P4carddwn.rom.

To summarize:

- To use the Swapbox utility: Use the released firmware file (\*card.rom)
- To copy to an IC card or DIMM plugged into the printer (from a PC through a parallel cable): Use the byte-swapped file (\*carddwn.rom - created by SSU byte swap)
- To copy directly to the printer's firmware flash ROM (from a PC through a parallel cable): Use the byte-swapped file (\*carddwn.rom - created by SSU byte swap)

## 1.2 SERVICE TOOLS

### 1.2.1 OPERATION PANEL

The locations of the keys on the operation panel are shown below.

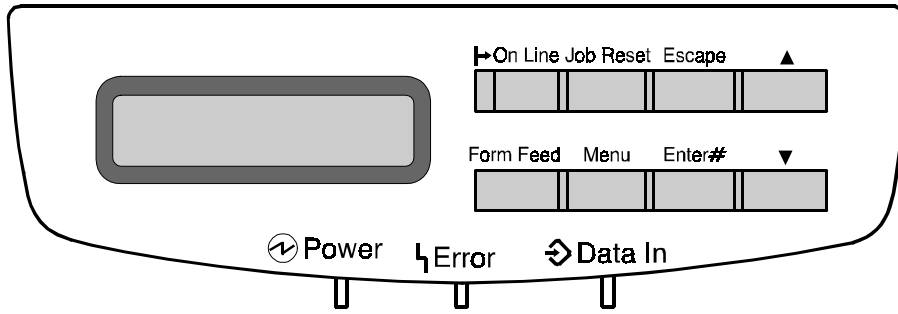

G031X504.WMF

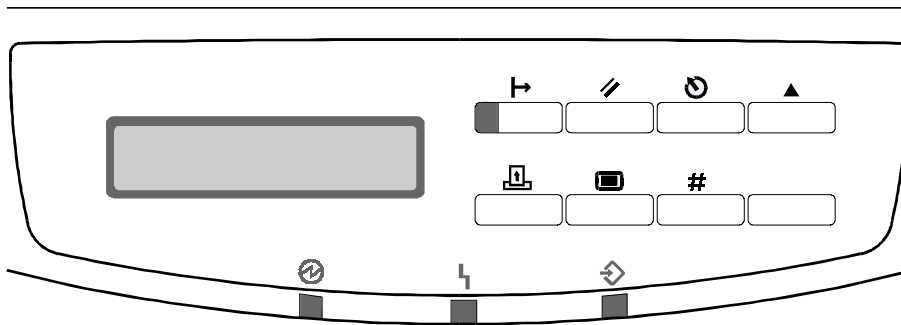

G031X506.WMF

## 1.2.2 SERVICE TOOL MENUS

There are two service menus that include tools for downloading firmware. These are the IC card boot service menu and the service tool menu.

### *IC Card Boot Service Menu*

#### *Entering This Menu*

1. Turn the printer off.
2. Turn on DIP SW 1 on the printer control board.
3. Plug the IC card into the IC card adapter, then connect it to the option bus connector on the printer control board.  
**NOTE:** The Stinger - P3 has two option bus connectors. The left connector can only be used for this function.  
 Do not use a blank IC card.
4. Turn the printer on. The IC card boot service menu will be displayed.

#### *Menu Contents*

The IC card boot service menu contains the following features.

Menu	Function
Update Firmware	Update controller firmware using an IC card. For details, see this appendix, and "Downloading New Controller Software" in section 4 of the service manual.
	Download Firmware
Download Firmware	Downloading firmware into the printer's flash memory from a PC through a parallel cable. See this appendix for details.
	Copy to DIMM
Copy to DIMM	Download firmware to a DIMM card from a PC through a parallel cable. See this appendix for details.
	Copy to CARD
Copy to CARD	Download firmware to an IC card from a PC through a parallel cable. See this appendix for details.
	Clear NVRAM
Clear NVRAM	Clear the NVRAM To clear the NVRAM, press the "Enter" key twice. Normally, NVRAM clear should not be used. <b>Note:</b> This resets all the settings stored in the NVRAM to their default settings. This procedure is required only after replacing the NVRAM chip.
	TEST Print
TEST Print	Print controller generated test pattern (Listed below – for factory use only)

## TEST Print menu

Sub menu	Function
Repeat	Repeat latest action
Total Pattern	Print total pattern
2 x 2	Print 2 x 2 dots pattern for uniformity
4 x 4	Print 4 x 4 dots pattern for uniformity
Brown Fox	Print "Brown Fox" words
Flag Ship	Print checker pattern and black square
Fox Pattern	Print "Brown" words and black square
Blank	Print all blank data
Real 1,200 dpi	Print total pattern by 1200dpi
Regist Adjustment	Adjust main/sub registration
Free Size	Print 2 x 2 pattern on free size paper
Header Attach	Print with header dpi : 600 dpi/1,200 dpi/real 1,200 dpi Paper : Thick/Normal/Special sheet Tray : CS-S standard cassette : CS-1 second tray : CS-2 third tray : CS-M bypass tray Page : number of prints
EEPROM Clear	Clear the EEPROM on the ECB (Factory use)
Clear Counter	Clear the counters (Factory use)
Version Info	View the software version of pattern generator.

*Exiting This Menu*

1. Turn the printer off.
2. Remove the IC card and IC card adapter.
3. Turn DIP SW 1 to off.
4. Turn on the printer again.
5. Then, the user menu will appear.

**NOTE:** Don't forget to return DIP SW1 to the off position. Otherwise the printer will not boot.

## ***Service Tool Menu***

### ***Entering This Menu***

1. Turn off the printer.
2. Turn on the printer again while pressing the “On Line” and “Menu” keys together.
3. The service tool menu will be displayed.

**NOTE:** An IC card is not required to boot up to the service tool menu.

### ***Menu Contents***

<b>Menu Item</b>	<b>Contents</b>
Factory Test Pattern	This is the same as in the IC card boot service menu.
Downloading	This is the same as in the IC card boot service menu.
Clear NVRAM	This is the same as in the IC card boot service menu.
Copy to CARD	This is the same as in the IC card boot service menu.
DIMM to Memory	Downloads from a DIMM card plugged into the printer into the flash memory.

## **1.2.3 STINGER SERVICE UTILITY (SSU)**

To download firmware from a PC to the printer, SSU running on a Windows PC can be used.

**NOTE:** Use only the “Download” menu and “Byte Swap” buttons. The other buttons are for designer use only.

- a) Download button:  
Downloads new controller firmware into the printer.
- b) Byte Swap menu:  
Makes a byte-swapped file for downloading from PC to printer via a parallel cable.

SSU will be provided as an SSU.ZIP file. The SSU.ZIP includes seven files, as follows:

- download.hed
- gzip.exe
- Paiview.exe
- Pindump.exe
- stinger.exe
- stinger.ico
- Xpaipal.smp

## 1.3 USING AN IC CARD

### 1.3.1 PREPARING THE IC CARD

#### *Two Methods*

There are two ways to do this:

- Swapbox
- Copy to an IC card plugged into the printer, from a PC via a parallel cable

The Swapbox method is covered in a separate manual. In this appendix, we will concentrate on the second method.

If there is any firmware already on the IC card, it will be overwritten.

#### *Preparation*

In summary, the procedure is as follows:

1. Make a byte-swapped file of the firmware file on a PC.
  - Use the Byte Swap button in the Stinger Service Utility.
2. Copy this file from the PC to an IC card plugged into a Stinger P3 or P4 printer, via a parallel cable.
  - The computer must be connected to the printer with a parallel cable.
  - The IC card must be connected to the IC card adapter before being plugged into the printer.
  - Use either the Stinger Service Utility (for use with Windows systems) or MS-DOS (use the 'copy /b' command).

**NOTE:** When using the Windows utility, all Windows utility files must be copied to the same directory.

When using MS-DOS, download the download.hed file first (supplied with the Stinger Service Utility), then download the controller firmware file.

### Byte Swap Procedure

1. Start the service utility (click 'stinger.exe' or the SSU icon)

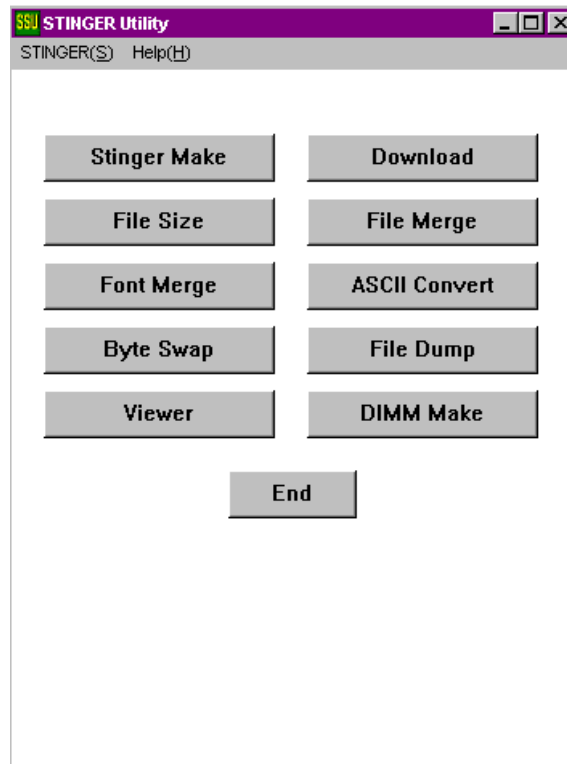

G031X523.PCX

2. Click the Byte Swap button.

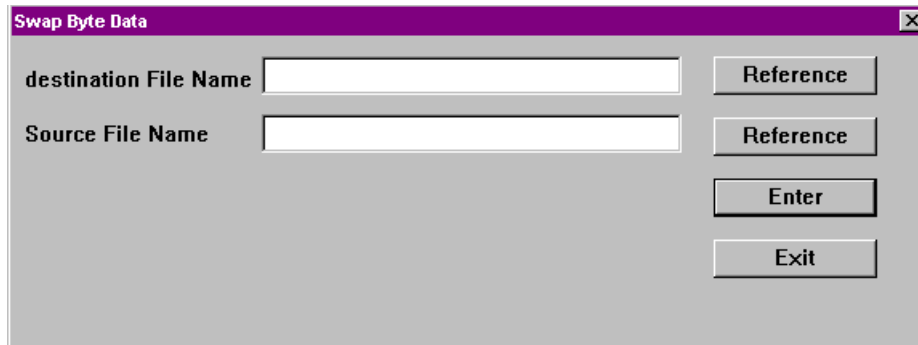

G031X540.PCX

3. Select the source file name (eg. P3card.rom) from the file list.
4. Enter the destination file name (eg. P3carddwn.rom).  
**NOTE:** Any destination file name can be used. However, the recommended file name is XXXdwm.rom. Using a standard naming system such as this will prevent confusion later.
5. Click Enter then click Exit. In the source file directory, XXXdwn.rom is created as the byte-swapped file.

***Downloading to the IC Card***

The firmware can be downloaded either with the Windows SSU utility or using MS-DOS.

***Stinger Service Utility***

First, prepare the printer.

1. Turn off the printer.
2. Connect the IC card to the IC card adapter, then connect the adapter to the option bus connector on the printer control board.  
**NOTE:** Stinger - P3 has two option bus connectors. The left side connector is used for the downloading.

Do not turn DIP SW 1 on, or the printer will boot from the IC card.

3. Turn the printer on while pressing the "On Line" key and "Menu" key together to enter the service tool menu.

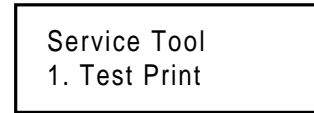

G031X532.WMF

4. Use the "arrow" key to select "Copy to card".

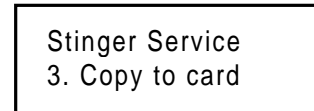

G031X539.WMF

5. Press the "Enter" key then the "Form Feed" key.



G031X519.WMF



Second, prepare the PC

6. Start the utility (click stinger.exe or the SSU icon). The downloading utility window is opened.

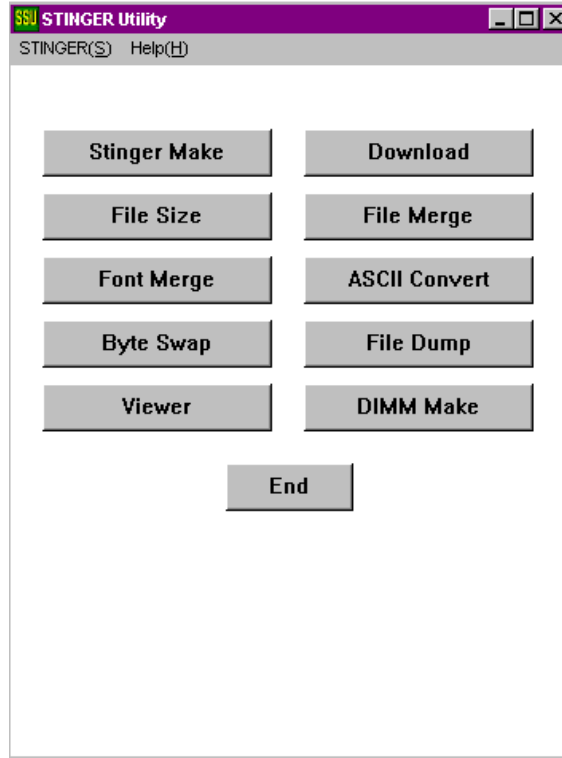

G031X523.PCX

7. Click the Download button in the Stinger utility window. The download window is displayed.

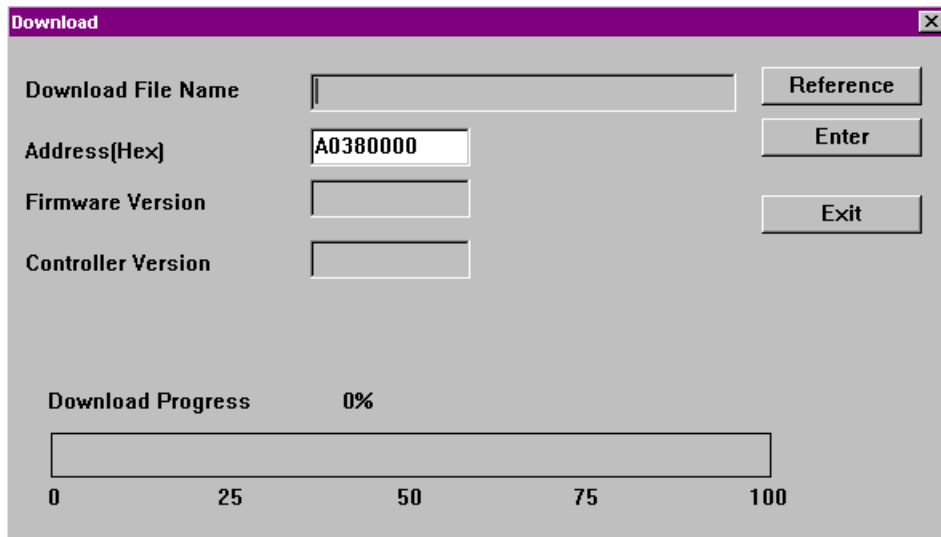

G031X524.PCX

- 8. Click the “Reference” key and select the firmware file that you wish to download (eg. P3cardwn.rom).

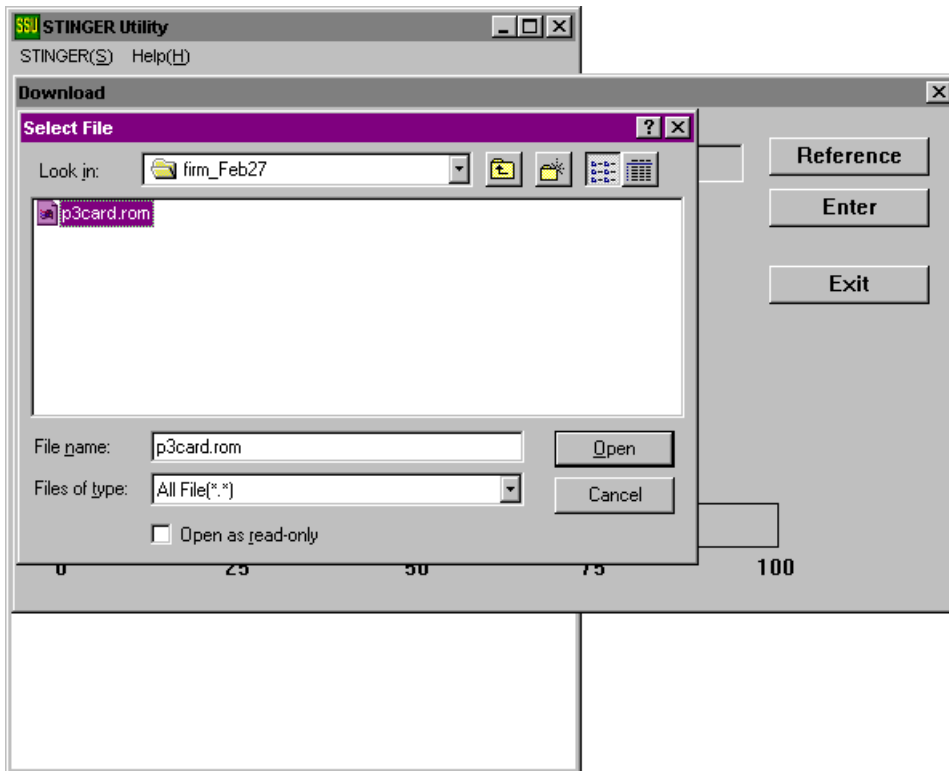

G031X525.PCX

**NOTE:** Only a byte-swapped file can be used for the download.

- 9. Then click the Enter button. The download is started.
  - The bar in the download window of the SSU goes up to 100 %.
  - The finishing message is displayed in the Windows utility.
  - When the downloading is finished, a message is displayed on the printer.

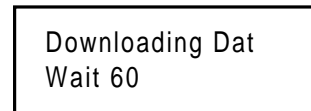

G031X538.WMF

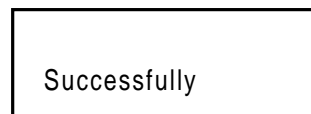

G031X536.WMF

- 10. Turn the printer off then on, and enter the service program mode.
- 11. Print the log print and check the controller firmware version.
- 12. Return to the user mode.

**NOTE:** There are two ways to go back to user mode from the service tool mode.

- 1) Press the “▲/▼” keys together. Then press the “Form Feed” key and the “Escape” key together. Then the initialization will start.
- 2) Turn the printer off and then on.



### *MS-DOS*

The DOS procedures are the same as those explained in the 'Copying from a PC Directly' section of this appendix.

### **1.3.2 DOWNLOADING FROM THE IC CARD TO THE PRINTER**

This is explained in 'Downloading New Controller Software' in section 4 of the service manual.

## 1.4 USING A DIMM

### 1.4.1 PREPARING THE DIMM

#### *Preparation*

In summary, the procedure is as follows:

1. Make a byte-swapped file of the firmware file on a PC.
  - Use the Byte Swap button in the Stinger Service Utility.
2. Copy this file from the PC to a DIMM card plugged into a Stinger P3 or P4 printer, via a parallel cable.
  - The computer must be connected to the printer with a parallel cable.
  - Use either the Stinger Service Utility (for use with Windows systems) or MS-DOS (use the 'copy /b' command).

**NOTE:** When using the Windows utility, all Windows utility files must be copied to the same directory.

When using MS-DOS, download the download.hed file first (supplied with the Stinger Service Utility), then download the controller firmware file.

#### *Byte Swap Procedure*

1. Start the service utility (click 'stinger.exe' or the SSU icon)

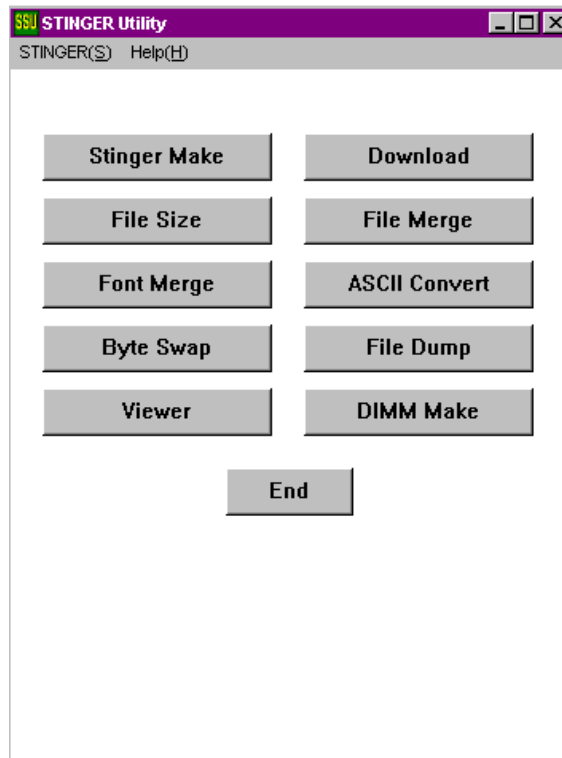

G031X523.PCX

- Click the Byte Swap button.

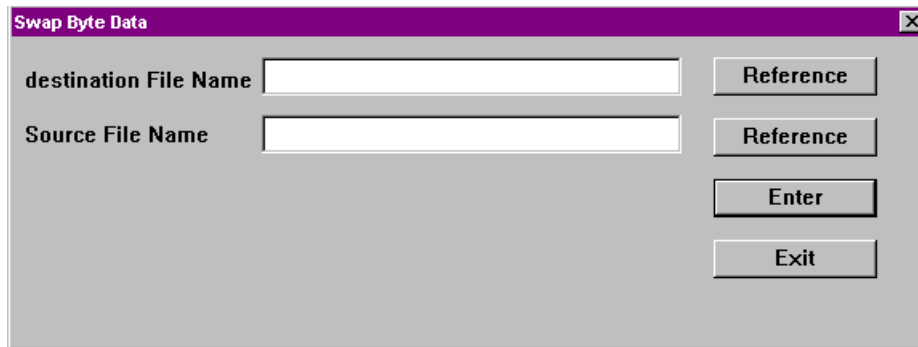

G031X540.PCX

- Select the source file name (eg. P3card.rom) from the file list.
- Enter the destination file name (eg. P3carddwn.rom).  
**NOTE:** Any destination file name can be used. However, the recommended file name is XXXdwm.rom. Using a standard naming system such as this will prevent confusion later.
- Click Enter then click Exit. In the source file directory, XXXdwn.rom is created as the byte-swapped file.

### ***Downloading to the DIMM card***

The firmware can be downloaded either with the Windows SSU utility or using MS-DOS. Any firmware already included on the DIMM card will be overwritten.

### ***Stinger Service Utility***

First, prepare the printer.

- Turn off the printer.
- Change DIP SW1 to ON on the printer control board.
- Connect the IC card to the IC card adapter, then connect the adapter to the option bus connector on the printer control board.  
**NOTE:** Stinger - P3 has two option bus connectors. The left side connector is used for the downloading.  
 The IC card must contain firmware for the printer; a blank IC card will not boot up the printer.
- Plug the DIMM card into the printer control board.
- Turn on the printer. Then the printer will boot from the firmware in the IC card.
  - The service menu will appear as follows.

Stinger Service 1. Update Firmwr
-------------------------------------

G031X537.WMF

6. Use the “arrow” key to select “Copy to DIMM”.

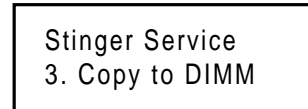

G031X522.WMF

7. Press the “Enter” key then the “Form Feed” key.

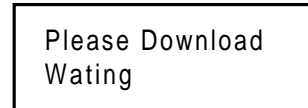

G031X519.WMF

Second, prepare the PC

8. Start the utility (click stinger.exe or the SSU icon). The downloading utility window is opened.

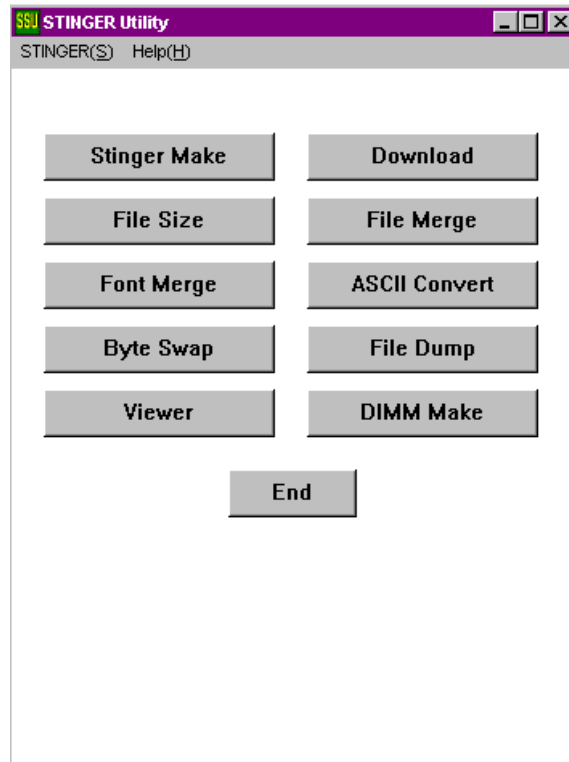

G031X523.PCX

9. Click the Download button in the Stinger utility window.

10. The download window is displayed.

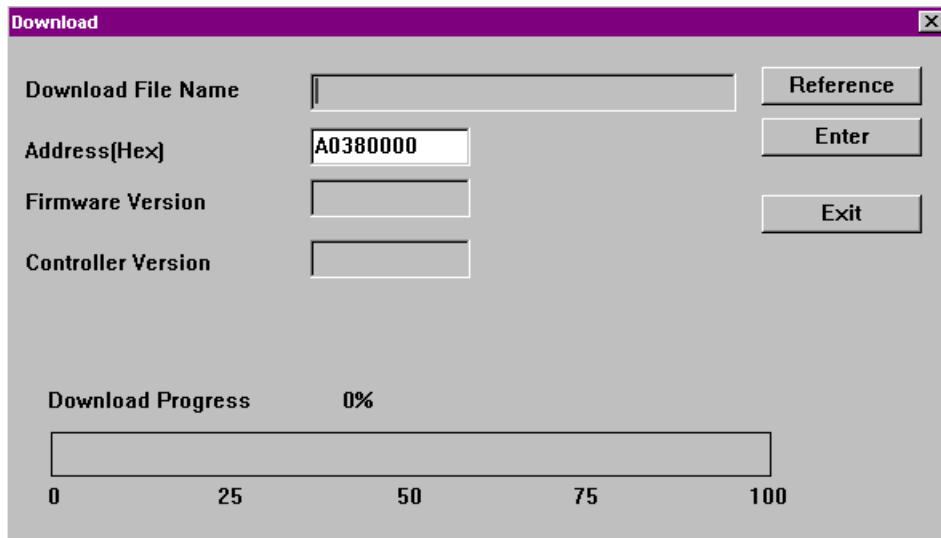

G031X524.PCX

11. Click the “Reference” key and select the firmware file that you wish to download (eg. P3cardwn.rom).

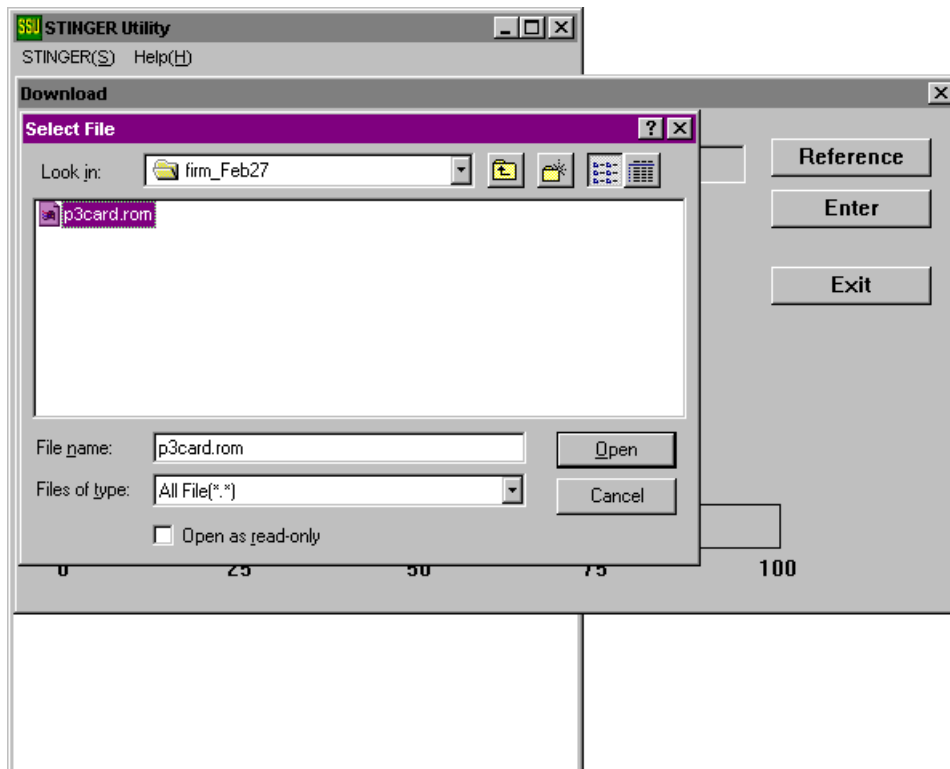

G031X525.PCX

**NOTE:** Only a byte-swapped file can be used for the download.

12. Then click the Enter button. The download is started.

- The bar in the download window of the SSU goes up to 100 %.
- The finishing message is displayed in the Windows utility.
- When the downloading is finished, a message is displayed on the printer.

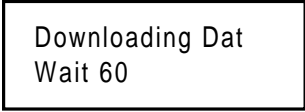

Downloading Data  
Wait 60

G031X538.WMF

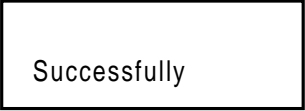

Successfully

G031X536.WMF

13. Turn the printer off then on, and enter the service mode.

14. Print the log print and check the controller firmware version.

15. Turn the printer off and then on to return to the user mode.



### *MS-DOS*

The DOS procedures are the same as those explained in the 'Copying from a PC Directly' section of this appendix.

The DIMM card now contains new firmware. The following procedure explains how to install the new firmware into the printer's flash memory.



## 1.4.2 DOWNLOADING FROM THE DIMM TO THE PRINTER

The firmware on a DIMM card can be copied to the flash ROM inside the printer.

To install the firmware, use the printer's service tool menu as shown below.

**NOTE:** The printer cannot boot from a DIMM card.

1. Turn off the printer.
2. Plug the DIMM card into the printer control board.
3. Turn the printer on while pressing the "Online" and "Menu" keys together, to enter the service tool menu.

Service Tool  
1. Test Print

G031X532.WMF

4. Use the "arrow" key to select "DIMM to Memory".

Service Tool  
5. DIMM to Memory

G031X541.WMF

5. Press the "Enter" key.

5. DIMM to Memory  
Sure?

G031X542.WMF

6. Press the "Form Feed" key. Then downloading starts.

STINGER version  
Wait

G031X543.WMF

7. This message shows that downloading has finished successfully.

STINGER version  
Successfully

G031X544.WMF

8. Turn off the printer.
9. Detach the DIMM card.
10. Turn the printer on again and enter the service mode.

**NOTE:** If SC2800 appears, you forgot to take the DIMM out.

11. Print the log print and check the controller firmware version.
12. Return to user mode.

**NOTE:** There are two ways to go back to user mode from the service mode.

- 1) Press the "Form Feed" key and the "Escape" key together. Then initialization will start.
- 2) Turn the printer off then on.

## 1.5 COPYING FROM A PC DIRECTLY

### 1.5.1 PREPARATION

In summary, the procedure is as follows:

1. Make a byte-swapped file of the firmware file on a PC.
  - Use the Byte Swap button in the Stinger Service Utility.
2. Copy this file from the PC to the Stinger P3 or P4 printer, via a parallel cable.
  - The computer must be connected to the printer with a parallel cable.
  - Use either the Stinger Service Utility (for use with Windows systems) or MS-DOS (use the 'copy /b' command).

**NOTE:** When using the Windows utility, all Windows utility files must be copied to the same directory.

When using MS-DOS, download the download.hed file first (supplied with the Stinger Service Utility), then download the controller firmware file.

#### *Byte Swap Procedure*

1. Start the service utility (click 'stinger.exe' or the SSU icon)

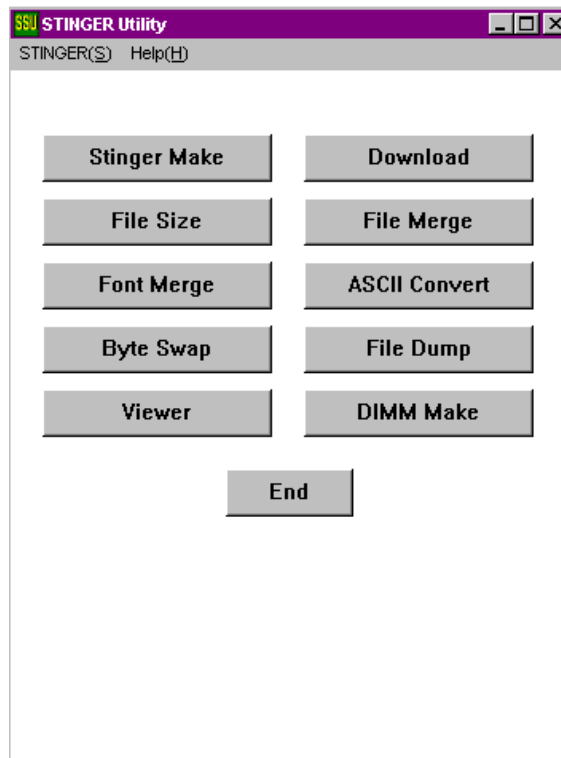

G031X523.PCX

1. Click the Byte Swap button.

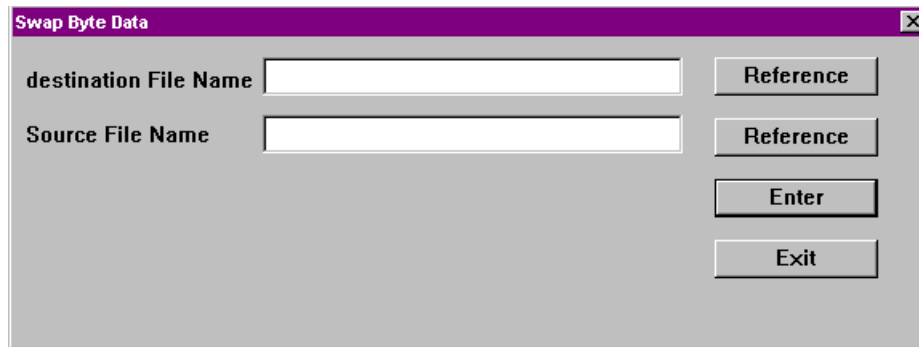

G031X540.PCX

2. Select the source file name (eg. P3card.rom) from the file list.
3. Enter the destination file name (eg. P3carddwn.rom).  
**NOTE:** Any destination file name can be used. However, the recommended file name is XXXdwn.rom. Using a standard naming system such as this will prevent confusion later.
4. Click Enter then click Exit. In the source file directory, XXXdwn.rom is created as the byte-swapped file.

## 1.5.2 DOWNLOADING TO THE FLASH MEMORY

### *MS-DOS Procedure*

First, prepare the printer.

1. Turn the printer off.
2. Turn the printer on while pressing the “On Line” key and the “Menu” key together to enter the service tool menu.



G031X532.WMF

3. Use the “arrow” keys to select Download.

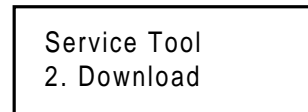

G031X533.WMF

4. Press the “Enter” key then press the “Form Feed” key.

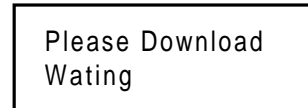

Then, prepare the host PC

G031X519.WMF

5. Start DOS, or open a DOS window.
6. Do the following steps.
  - C: > cd <path name for download.hed and controller firmware> <Enter>
  - C: > copy /b download.hed prn <Enter>
  - wait for five or more minutes ----

During this period, the printer display is as shown.

C: > copy/ b <download file name eg. XXXdwn.rom>  
prn <Enter>

The C: prompt returns.

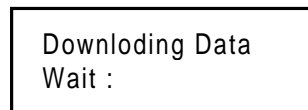

G031X534.WMF

7. When the download is finished, the printer’s display is as shown.

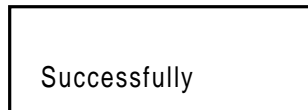

G031X536.WMF

8. Turn the printer off then on, then enter the service mode.
9. Print the log print and check the controller firmware version.
10. Return to the user mode.

**NOTE:** There are two ways to go back to user mode from the service tool mode.

- 1) Press the “▲/▼” keys together. Then press the “Form Feed” key and the “Escape” key together. Then initialization will start.
- 2) Turn the printer off and on.

**Windows Procedure**

First, prepare the printer.

- 1. Turn the printer off.
- 2. Turn the printer on while pressing the "On Line" key and the "Menu" key together to enter the service tool menu.

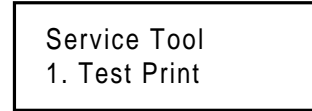

G031X532.WMF

- 3. Use the "arrow" keys to select Download.

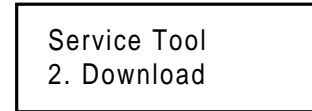

G031X533.WMF

- 4. Press the "Enter" key then press the "Form Feed" key.



G031X519.WMF

Second, prepare the PC

- 5. Start the utility (click stinger.exe or the SSU icon). The downloading utility window is opened.

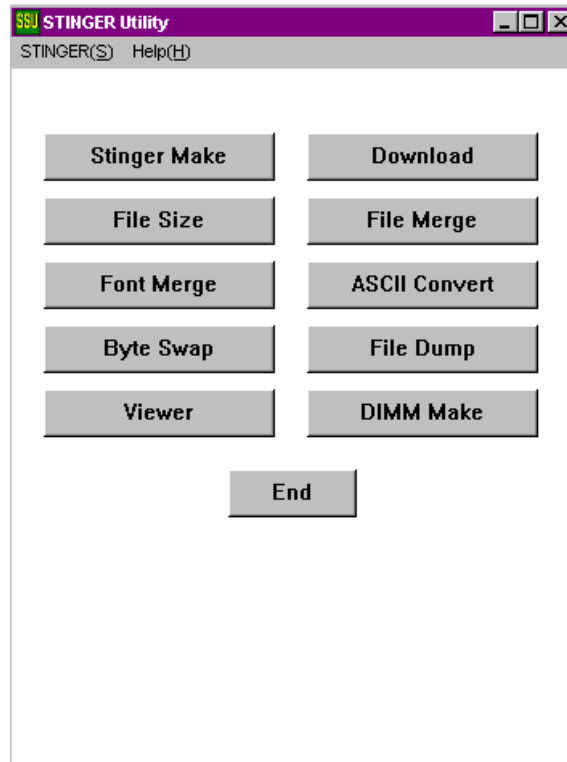

G031X523.PCX

- 6. Click the Download button in the Stinger utility window.
- 7. The download window is displayed.

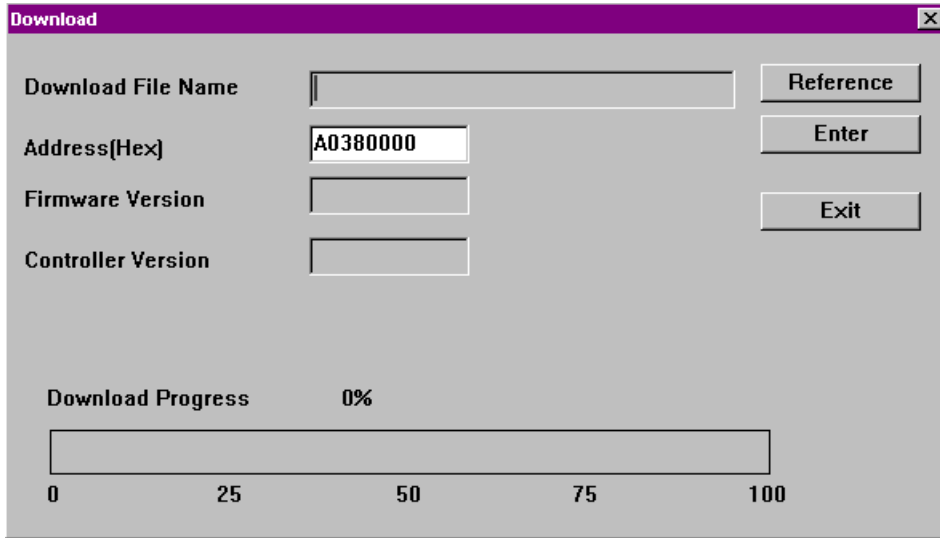

G031X524.PCX

- 8. Click the "Reference" key and select the firmware file that you wish to download (eg. P3cardwn.rom).

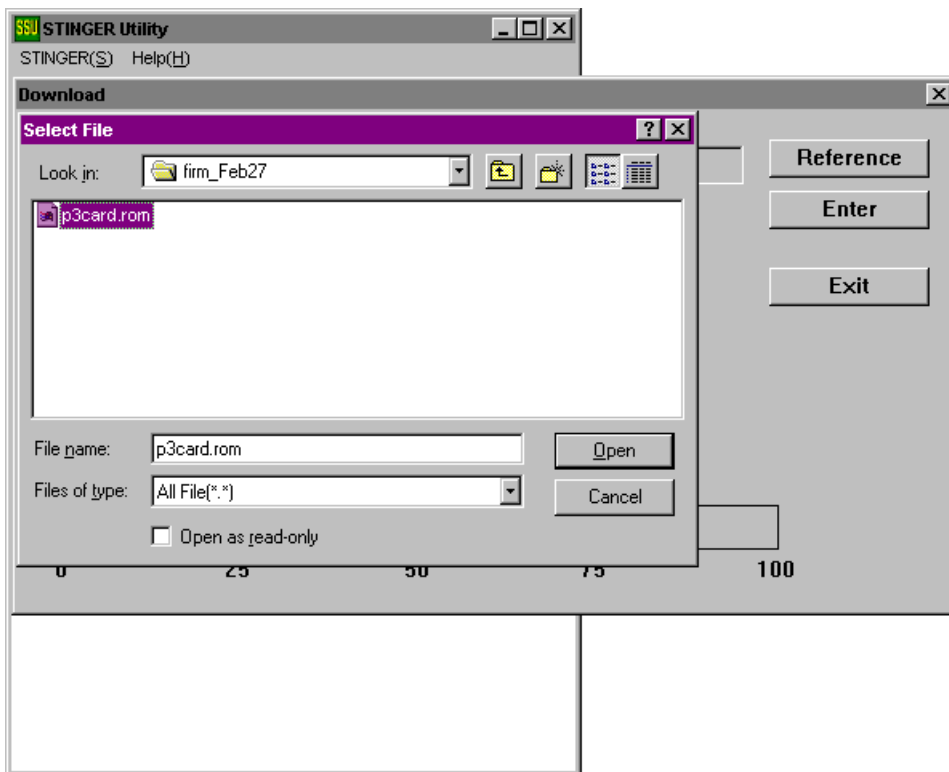

G031X525.PCX

**NOTE:** Only a byte-swapped file can be used for the download.

9. Then click the Enter button. The download starts.

---- wait for a few minutes ----

During this period, the printer display is as shown.

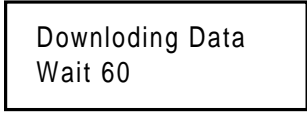
A rectangular box representing a printer display. Inside the box, the text "Downlodging Data" is on the top line and "Wait 60" is on the bottom line.

G031X535.WMF

- The bar in the download window of the SSU goes up to 100 %.
- The finishing message is displayed.
- When the download is finished, the printer display is as shown.

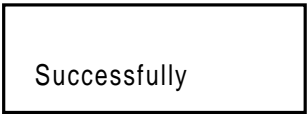
A rectangular box representing a printer display. Inside the box, the text "Successfully" is centered.

G031X536.WMF

10. Turn the printer off then on, and enter the service mode.

11. Print the log print and check the controller firmware version.

12. Return to the user mode.

**NOTE:** There are two ways to go back to user mode from the service tool mode.

- 1) Press the “▲/▼” keys together. Then press the “Form Feed” key and the “Escape” key together. Then initialization will start.
- 2) Turn the printer off and then on.

## 1.6 SSU TROUBLESHOOTING

This section explains problems that may occur when using the SSU (Stinger service utility).

When 'stinger.exe' or the SSU icon is clicked, SSU starts. The following error messages may appear when the download button is clicked. These errors are created by SSU.

1. "LPTx open error"
2. "File (filename.P00) Write error"
3. "File (filename.P00) Create Error"

### **Symptoms**

#### **1. "LPT2 open error"**

This may appear in a message window when the download button is clicked to start downloading.

SSU uses the lpt1 port to send the data. When the default printer is connected to the lpt2 port, for example, the SSU cannot send the data to lpt1 and it tries to send the data to lpt2. However, SSU cannot open lpt2.

The default printer must be connected to lpt1.

Countermeasure

Connect the port of the default printer to lpt1 (use the port setting in the Details tab of the printer properties).

#### **2. "File (filename.P00) Write error"**

SSU checks the rom file attribute when it starts to send the data. This error message appears when the file attribute is read-only.

Countermeasure

Open the file properties (using Windows Explorer) and uncheck the read-only attribute.

#### **3. "File (filename.P00) Create Error"**

SSU creates a temporary file in the same directory as the rom file. If the rom file is on a CD-ROM for example, SSU cannot create a temporary file. Also, if the rom file is in a network directory that is not shared, SSU cannot create a temporary file.

Countermeasure

The rom file must be in a local directory.



# Stinger - P3

